

# **KURZWEIL K2000/K2000R SERVICE MANUAL**

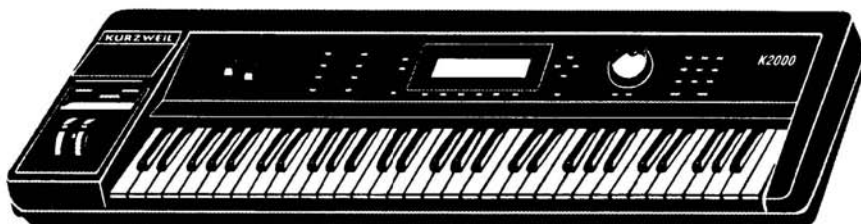

**KURZWEIL**

*Music Systems*

Kurzweil is a product line of Young Chang America, Inc.

## CALVIN Version Service Manual

This service manual does not include schematics. The schematic set was removed to reduce the file size for improvement of email transfer and downloads. To obtain a .pdf file of the schematics contact us and ask for the Mark 5 schematic set.

KURZWEIL MUSIC SYSTEMS  
AND Music Corp  
9501 Lakewood Drive, SW Ste. D  
Lakewood, Washington 98499  
(253)589-3200

# **!\*\* IMPORTANT INFORMATION \*\*!**

## **READ THIS PAGE BEFORE PROCEEDING!**

**THERE ARE NO USER SERVICEABLE COMPONENTS OR ASSEMBLIES INSIDE THIS INSTRUMENT.**

This service manual is written for use by qualified service personnel only. Possession of this service manual does not qualify its owner or user as a competent service technician on this product.

Any attempts to repair, modify, adjust or service any internal component or assembly by non-approved personnel may void all existing warranties on this instrument and any installed options.

Only the Kurzweil Service Department has the authority to make the determination as to who is a qualified technician.

For further information, contact the Kurzweil National Service Manager at (310) 926-3200.



**WARNING**

**RISK OF ELECTRIC SHOCK  
DO NOT OPEN**



**EXPLANATION OF GRAPHIC SYMBOLS:**

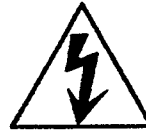

The lightning flash with the arrowhead symbol, within an equilateral triangle, is intended to alert the user to the presence of uninsulated "dangerous voltage" within the product's enclosure that may be of sufficient magnitude to constitute a risk of electric shock to persons.



The exclamation point within an equilateral triangle is intended to alert the user to the presence of important operating and maintenance (servicing) instructions in the literature accompanying the product.

**WARNING: TO REDUCE THE RISK OF ELECTRIC SHOCK,  
DO NOT REMOVE THE BOTTOM.  
NO USER SERVICEABLE PARTS INSIDE.  
REFER SERVICING TO QUALIFIED SERVICE PERSONNEL.**

**IMPORTANT SAFETY AND INSTALLATION INSTRUCTIONS**

**INSTRUCTIONS PERTAINING TO THE RISK OF FIRE, ELECTRIC SHOCK, OR INJURY TO PERSONS**

**WARNING** - When using electric products, basic precautions should always be followed, including the following:

1. Read all of the Safety and Installation Instructions and Explanation of Graphic Symbols before using the product.
2. This product must be grounded. If it should malfunction or breakdown, grounding provides a path of least resistance for electric current to reduce the risk of electric shock. This product is equipped with a power supply cord having an equipment-grounding conductor and a grounding plug. The plug must be plugged into an appropriate outlet which is properly installed and grounded in accordance with all local codes and ordinances.
- DANGER** - Improper connection of the equipment-grounding conductor can result in a risk of electric shock. Do not modify the plug provided with the product - if it will not fit the outlet, have a proper outlet installed by a qualified electrician. Do not use an adaptor which defeats the function of the equipment-grounding conductor. If you are in doubt as to whether the product is properly grounded, check with a qualified serviceman or electrician.
3. **WARNING** - this product is equipped with an AC input voltage selector. The voltage selector has been factory set for the main supply voltage in the country where this unit was sold. The setting of the voltage selector can be seen just to the right of the power input receptacle on the back of the product. Changing the voltage selector may require the use of a different power supply cord or attachment plug, or both. To reduce the risk of fire or electric shock, refer servicing to qualified maintenance personnel.
4. Do not use this product near water - for example, near a bathtub, washbowl, kitchen sink, in a wet basement, or near a swimming pool, or the like.
5. This product should only be used with a stand or cart that is recommended by the manufacturer.
6. This product, either alone or in combination with an amplifier and speakers or headphones, may be capable of producing sound levels that could cause permanent hearing loss. Do not operate for a long period of time at a high volume level or at a level that is uncomfortable. If you experience any hearing loss or ringing in the ears, you should consult an audiologist.
7. The product should be oriented such that its location or position does not interfere with its proper ventilation.
8. The product should be located away from heat sources such as radiators, heat registers, or other products that produce heat.
9. The product should be connected to a power supply only of the type described in the operating instructions or as marked on the product.
10. This product may be equipped with a polarized line plug (one blade wider than the other). This is a safety feature. If you are unable to insert the plug into the outlet, contact an electrician to replace your obsolete outlet. Do not defeat the safety purpose of the plug.
11. The power supply cord of the product should be unplugged from the outlet when left unused for a long period of time. When unplugging the power supply cord, do not pull on the cord, but grasp it by the plug.
12. Care should be taken so that objects do not fall and liquids are not spilled into the enclosure through openings.
13. The product should be serviced by qualified service personnel when:
  - A. The power supply cord or the plug has been damaged; or
  - B. Objects have fallen, or liquid has been spilled into the product; or
  - C. The product has been exposed to rain; or
  - D. The product does not appear to be operating normally or exhibits a marked change in performance; or
  - E. The product has been dropped, or the enclosure damaged.
14. Do not attempt to service the product beyond that described in the user maintenance instructions. All other servicing should be referred to qualified service personnel.
15. **WARNING** - Do not place objects on the product's power supply cord, or place the product in a position where anyone could trip over, walk on, or roll anything over cords of any type. Do not allow the product to rest on or be installed over cords of any type. Improper installations of this type create the possibility of a fire hazard and/or personal injury.

**SAVE THESE INSTRUCTIONS**

## RADIO AND TELEVISION INTERFERENCE

---

**Warning:** Changes or modifications to this instrument not expressly approved by Young Chang could void your authority to operate the instrument.

**Important:** When connecting this product to accessories and/or other equipment use only high quality shielded cables. The cable(s) supplied with this instrument must be used.

**Note:** This instrument has been tested and found to comply with the limits for a Class B digital device, pursuant to Part 15 of the FCC Rules. These limits are designed to provide reasonable protection against harmful interference in a residential installation. This instrument generates, uses, and can radiate radio frequency energy and, if not installed and used in accordance with the instructions, may cause harmful interference to radio communications. However, there is no guarantee that interference will not occur in a particular installation. If this instrument does cause harmful interference to radio or television reception, which can be determined by turning the instrument off and on, the user is encouraged to try to correct the interference by one or more of the following measures:

- Reorient or relocate the receiving antenna.
- Increase the separation between the instrument and the receiver.
- Connect the instrument into an outlet on a circuit different from the
- If necessary consult your dealer or an experienced radio/television technician for additional suggestions. You may find the following booklet prepared by the Federal Communications Commission to be helpful:  
"How To Identify and Resolve Radio-TV Interference Problems"  
This booklet is available from the U.S. Government Printing Office, Washington, D.C. 20402, Stock No. 004-000---345-4.

---

### NOTICE

This apparatus does not exceed the Class B limits for radio noise emissions from digital apparatus set out in the Radio Interference Regulations of the Canadian Department of Communications.

### AVIS

Le present appareil numerique n'emet pas de bruits radioelectriques depassant les limites applicables aux appareils numeriques de la class B prescrites dans le Reglement sur le brouillage radioelectrique edicte par le ministere des Communications du Canada.

---

© 1992 All rights reserved. Kurzweil is a product line of Young Chang Akki Co., LTD.

Kurzweil, K2000, and MIDIScope are trademarks of Young Chang Akki Co., LTD. The names Akai, S1000, Apple, MacIntosh, DX7, IBM, DOS, MS-DOS, and Roland are registered trademarks of the respective companies using these names.

This manual is current with K2000 version 1.00 software.

Product features and specifications are subject to change without notice.

**K2000/K2000R TABLE OF CONTENTS**

NOTE: Any sections not specifically identified with the K2000 or the K2000R apply to both units.

SPECIFICATIONS	1	
GLOSSARY	5	
		<b>1</b>
<hr/>		
SETUP	1	
K2000 OPERATIONAL CHECKOUT	5	
K2000 POWER-UP CHECK	11	
K2000R OPERATIONAL CHECKOUT	17	
		<b>2</b>
<hr/>		
K2000 DISASSEMBLY/ACCESS	1	
K2000R DISASSEMBLY/ACCESS	7	
		<b>3</b>
<hr/>		
K2000 MAINTENANCE	1	
K2000/K2000R TROUBLESHOOTING	7	
DIAGNOSTICS	11	
K2000R MAINTENANCE	47	
		<b>4</b>
<hr/>		
OPTIONS	A	
TECHNICAL THEORY	1	
		<b>5</b>
<hr/>		
K2000 PARTS LIST	1	
K2000R PARTS LISTS	9	
		<b>6</b>
<hr/>		
K2000/K2000R WIRING GUIDE	1	
		<b>7</b>
<hr/>		
SCHEMATICS/DIAGRAMS		
		<b>8</b>
<hr/>		

## 1.0 K2000 SPECIFICATIONS

### 1.1 K2000 FEATURES

- 61-key spring return synth action keyboard
- Sends and receives mono (channel) pressure; receives poly pressure
- Spring loaded Pitch Wheel
- Full throw Modulation Wheel, programmable
- Volume Slider
- Programmable Controller Slider
- Two programmable switch pedal inputs
- Programmable continuous controller input
- 240 x 64-pixel backlit graphic display with adjustable contrast
- 3.5 inch floppy disk drive, for DD or HD disks, DOS compatible
- MIDI IN, THRU and OUT
- 24-note polyphony with dynamic voice allocation
- Multi-timbral, for multi-track sequencing and recording
- 199 factory preset programs, and 100 factory preset setups
- Up to 3 layers per program, up to 32 layers for programs on drum channel
- 3-zone setups transmit on 3 MIDI channels with independent programmable controls
- 15,000 note scratchpad sequencer for recording from keyboard or via MIDI; loads and plays MIDI Type 0 sequences
- Easy-to-use programming interface including soft buttons, Alpha Wheel, and alphanumeric pad
- 8 Megabytes of 16-bit sample ROM, including acoustic instrumental sounds, waveforms, and noise
- 20 KHz maximum bandwidth
- Optional stereo sampler with analog and digital inputs
- Sound ROM expandable to a total of 24 Megabytes
- Sound sample playback
- 4 SIMM sockets for optional sample RAM - up to 64 Megabytes
- Akai™ S1000 sample disk compatibility
- Two 1/4 inch mixed audio outputs (stereo pair)
- Four 1/4 inch audio outputs programmable as 2 stereo pairs or as four separate outputs, with insert capability for effects patching
- Stereo headphone jack
- 128 KB battery backed RAM for user programs, setups and other objects
- SCSI port for connection with external SCSI disk or CD-ROM
- Optional internal hard disk
- Real-time DSP for each voice: 31 programmable DSP algorithms incorporating filters, EQ, distortion, panning, pulse width modulation, and more; up to 3 programmable DSP functions per voice
- Filters: Lowpass, Highpass, Allpass, Bandpass, Notch, programmable resonance
- Programmable stereo multi-effects on MIX outputs, including simultaneous reverb, chorus, delay, flanging, EQ - and more
- Real-time internal and MIDI control of effects parameters
- MIDI standard sample dump capability
- System Exclusive implementation
- MIDIScope™, for analyzing MIDI events

**1.2 K2000R FEATURES**

The Kurzweil K2000R offers the same powerful features as the K2000 including:

- Convenient 3-space rack module
- 240 x 64-pixel backlit graphic display with adjustable contrast
- 3.5-inch floppy disk drive, for DD or HD disks, DOS compatible
- MIDI In, Thru, and Out
- MIDI LED to indicate MIDI activity
- 24-note polyphony with dynamic voice allocation
- Multi-timbral, for multi-track sequencing and recording
- 199 factory preset programs, and 100 factory preset setups
- Up to 3 layers per program, up to 32 layers for programs on drum channel
- Receives mono (channel) pressure and poly (key) pressure
- 3-zone setups transmit on 3 MIDI channels with independent programmable controls
- 15,000 note scratchpad sequencer for recording from keyboard or via MIDI; loads and plays MIDI Type 0 sequences
- Easy-to-use programming interface including soft buttons, Alpha Wheel, and alphanumeric pad
- 20KHZ maximum bandwidth
- Stereo sample playback capability Programmable stereo multi-effects on MIX outputs, including simultaneous reverb, chorus, delay, flanging, EQ...and more
- Realtime internal and MIDI control of effects parameters
- Kurzweil's proprietary VAST™ (Variable Architecture Synthesis Technology) system
- 31 sound shaping algorithms
- Three programmable DSP functions for each voice
- 8 Megabytes of ROM (16-bit) samples
- Built-in 3.5" floppy drive (HD/DD)
- Two SCSI buses, for connection with external SCSI disks, CD-ROM, or MacIntosh computers.
- Ten analog outputs, including four stereo pairs and a stereo master pair
- Internal ROM expansion capability to 24 Megabytes
- Two 8 Megabyte ROM sound blocks (ROM-1, ROM-2) can be purchased and installed separately
- Sampling Option Kit (DSMP-R), which allows for user sampling via analog, digital or optical inputs
- AES-EBU and SPDIF digital ins and outs are offered; the version 2.0 software\* included with this kit provides extensive sample editing and audio processing capabilities
- Sample RAM can be expanded via four standard SIMM memory modules (up to 64 Megabytes)
- Program/Sequence memory expansion option (DP-RAM) expands battery backed memory from 120K to 760K
- CD-ROM compatible with Sony and Toshiba drives
- Capacity for an optional internal hard drive (up to 240 Megabytes or more)
- Standard equipped with version 1.27 software, allowing the user to port over stereo samples via the SCSI bus (SMDI protocol) using Passport's Alchemy™ or through sample dump over MIDI
- Reads sample data from Akai S1000 HD disks

\*Version 2.0 software, which is part of the SMP-R sampling option, allows for graphic waveform editing via the built-in 240 x 64 display. Features include powerful sample editing and DSP functions (time compression/expansion, sample rate conversion, sample mixing and splicing, normalizing gain, audible sample cueing, crossfade looping, auto looping, fade in/out and more).

# SECTION 1

2000SPEC.DOC 01/03/93

Version 2.0 also adds extensive library compatibility functions to the K2000/K2000R, including the ability to read Ensoniq™ EPS disks (samples, keymaps and constructs programs) and Akai™ S1000 (samples, keymaps and constructs programs). This version also provides visual editing of K2000/K2000R's internal ROM samples as well as RAM samples, plus user-programmable loop type per sample (forward, bi-directional, off) and direction (forward, reverse), new alternate release parameters (samples may now play after the release loop) and much more.

Version 2.0 software will also be available separately from the Sampling Option Kit.

## 1.3 ENVIRONMENTAL SPECIFICATIONS

### Temperature ranges

For operation:	minimum	41° F	(5° C)
	maximum	104° F	(40° C)
For storage:	minimum	-13° F	(-25° C)
	maximum	186° F	(85° C)

Relative humidity ranges (non-condensing): Operation and storage = 5 - 95%

## 1.4 PHYSICAL SPECIFICATIONS

### Overall dimensions: K2000

Width	40 15/16 in.	104 cm
Depth	13 7/16 in.	34.1 cm
Height	4 1/8 in.	10.5 cm
Weight	26 lb.	11.8 kg

### Overall dimensions: K2000R

Width	16.9 in.*	43 cm
Depth	13.9 in.	35.4 cm
Height	5.1 in.	13 cm
Weight	22 lb.	10 kg

\* Excluding the rack-mount brackets

## 1.5 ELECTRICAL SPECIFICATIONS

AC supply: selectable; 100V, 120V, 220V, 240V; .75 amps at 120 volts nominal

Safe voltage ranges (volts rms)

Voltage setting:	100V	120V	220V	240V
Safe voltage range:	85 - 107V	95 - 125V	180 - 232V	190 - 250V
Safe frequency range:	48 - 65 Hz	48 - 65 Hz	48 - 65 Hz	48 - 65 Hz

If the voltage drops below the minimum safe level at any voltage setting, the K2000 will reset, but no data will be lost. If the voltage exceeds the maximum safe level, the K2000 may overheat.

SPECIFICATIONS SUBJECT TO CHANGE WITHOUT NOTICE



**NOTES**

**1.6 GLOSSARY OF TERMS**

---

<b>Algorithm</b>	In the K2000, a preset configuration of programmable digital signal processing functions. Each of a program's layers uses its own algorithm, which determines the type of synthesis each layer uses to generate its sound.
<b>Aliasing</b>	A type of distortion which occurs in digitally sampled sounds when higher pitches (increased sample playback rates) introduce partials that were not present in the original sound. These partials may or may not be musically useful.
<b>Amplitude</b>	The intensity of a signal, perceived as loudness in the case of audio signals.
<b>Analog</b>	A term used widely in electronics-related fields to describe a method of representing information, in which the method of representation resembles the information itself. Analog synthesizers, for example, use gradual variations in electrical voltage to create and modify sounds. The oscillations in voltage are analogous to the waveforms of the sounds they generate. Compare digital.
<b>Bandwidth</b>	In terms of sound generation, the range of frequencies within which a device functions. The human ear has a "bandwidth" of almost 20 KHz (it can distinguish sound at frequencies from 20 Hz to 20 KHz). The K2000's 20 KHz bandwidth enables it to produce sounds which span the entire range of human hearing.
<b>Bank</b>	There are two types of banks in the K2000's memory: memory banks, which store and organize the programs and other objects you create, and Quick Access banks, where you can store programs and setups for one-button access while in Quick Access mode.
<b>Cent</b>	1/100th of a semitone. The standard increment for fine adjustment of pitch.
<b>Continuous Control</b>	A device which converts motion into a range of 128 possible values which can modulate a sound source. The Mod Wheel, a standard volume pedal, and controllers like Breath and Aftertouch are continuous controls. Compare switch controls.
<b>Control Source</b>	Anything which can be used to modify some aspect of a program's sound. LFOs, envelopes, Mod Wheel messages (MIDI 01), and FUNs are just a few examples of the K2000's control sources.
<b>DSP</b>	Digital Signal Processing.

- DSP Functions** the K2000's collection of digital signal processing functions are what give the Variable Architecture Synthesis system its flexibility. Within each layer's algorithm, you can select from a long list of DSP functions like filters, EQ, oscillators, and a few that are unique to the K2000. Each DSP function has a corresponding page which enables you to assign numerous control sources to define how the DSP functions affect the sound of the program being edited.
- Default** The starting condition of a system. The settings for the K2000's parameters are at their defaults when you unpack it, and they stay there until you change them. A hard reset will erase RAM and restore all parameters to their defaults.
- Dialog** A page which prompts you to enter information that the K2000 needs in order to execute an operation. Dialogs appear, for example, when initiating a Save or Delete operation.
- Digital** A term used widely in electronics-related fields to describe a method of representing information as a series of binary digits (bits) - 1s and 0s. Digital computers process these strings of 1s and 0s by converting them into an electrical signal that is always in one of two very definite states: "on" or "off." this is much more precise than the analog method, therefore digital computers can operate at speeds unattainable by analog devices. Digital synthesizers like the K2000 are actually computers which process vast strings of digital information signals, eventually converting them (at the audio output) into the analog signals which flow into PAs and other audio systems. See also Analog.
- Drum Program** The only difference between a drum program and an ordinary program is the drum program can contain up to 32 layers instead of the usual maximum of three. Since each layer has its own keymap and algorithm (not to mention all the other control sources), this gives you enormous control over whatever sounds assigned to the layers in a drum program.
- DSP** Digital Signal Processing; this term refers to a vast range of functions, all of which have in common the fact that they act upon an electric current as it flows through a circuit or group of circuits. A simple form of signal processing is the distortion box used by many guitarists. Digital signal processing refers to similar processes which are performed by digital circuitry as opposed to analog circuitry. Many of the effects devices available today use digital signal processing techniques.

- Editor** The complete set of parameters used to modify a particular aspect of the K2000, for example, the currently selected program, which is modified with the Program Editor. The Program Editor spans several display pages, which can be viewed by using the soft buttons (labeled "<more>").
- Envelope** An aperiodic modifier. In other words, a way to cause a sound to change over time without necessarily repeating the change (unlike periodic modifiers like LFOs, which repeat at regular intervals).
- File** A group of objects stored to a floppy or hard disk, or loaded into the K2000's RAM from disk.
- Global** In this manual, used primarily in reference to control sources. A global control source affects all notes in a layer uniformly. If a layer uses a global control source, that control source begins to run as soon as the program containing it is selected. Its effect on each note will be completely in phase, regardless how many notes are being played. Compare Local.
- Hard Reset** Resets all parameter values to their defaults, and completely erases the contents of RAM. Press the Reset button in Master mode to do a hard reset. This is a quick way to restore the factory defaults to the K2000, but EVERYTHING in RAM (all the objects the owner/artist has created) will be erased, so objects you wish to keep should be saved to disk or SyxEx dump. A hard reset would not be used to recover if your K2000 is hung up, except as a last resort. See Soft Reset.
- Keymap** A keymap is a collection of samples assigned to specific keys and keystrike velocities. Keymaps usually contain numerous sample roots pitch-shifted across a range of several keys. When you strike a key, the keymap tells the K2000 what sound to play, at what pitch and at what loudness.
- LFO** Low frequency oscillator. An oscillator is an electrical signal which cycles regularly between a minimum and maximum amplitude. The simplest oscillating waveform is the sine wave, but an LFO waveform can have almost any shape. The number of times each second that an oscillator repeats itself is called its frequency, which is measured in Hertz (Hz). Anything up to 50 Hz is considered low-frequency in musical applications. Use an LFO whenever you want to generate a periodic (repeating) effect. Adjusting the rate of the LFO will change the repetition rate of the effect.

- Layer** A layer consists of a keymap processed through an algorithm. Layers can be stacked together within a program. Each layer uses one of the K2000's 24 available voices. Each K2000 program can contain up to three layers - except drum channel programs, which can contain up to 32 layers.
- Leslie Effect** This classic vibrato effect was originally created by mounting a speaker in its cabinet so the speaker could be rotated at varying speeds. This applied a vibrato of varying rate to all sounds played through the rotating speaker.
- Local** In this manual, used primarily in reference to control sources. A local control source affects each note in a layer independently. For example, if a local LFO is used as a control source, a separate LFO cycle will begin with each note start. The LFOs do not run in phase unless notes are started simultaneously. Compare Global.
- Memory Banks** The K2000's memory is divided into ten spaces where you can store any object you edit. These spaces are called banks. Each bank can hold up to 100 objects of each type, so we refer to them as the 100s bank, the 200s bank, and so on. The ID of an object determines in which bank it is to be stored. An object with an ID of 399, for example, would be stored in the 300s bank. ROM objects are stored in the Zeros and 100s banks. RAM objects can be stored in any bank.
- MIDI** Musical Instrument Digital Interface. A specialized format for representing musical information in terms of standardized computer data, which enables electronic musical instruments to communicate with computers.
- MIDI Device** Any device - keyboard, computer, wind instrument, etc. - which is capable of transmitting and receiving MIDI messages.
- MIDI Master** A MIDI device which is configured to control one or more other MIDI devices. The MIDI Out port of the master is connected by cable to the MIDI In port(s) of the slave device(s).
- MIDI Slave** A MIDI device which is configured to receive MIDI messages from a master device. The MIDI In port of the slave is connected by cable to the MIDI Out port of the master.
- NL DSP Function** Non-linear DSP functions like SHAPER and WRAP add waveforms to those already present in a sound, while linear DSP functions act upon the existing waveforms without adding new ones.

## SECTION 1

GLOSSARY.DOC 12/13/92

- Note State** Any K2000 is either on or off; this is its note state. Normally, any given note's Note State switches on when you strike the key for that note. It switches off when you release the key, and any sustain controls you may have applied to the note (Sustain or Sostenuto pedal, etc.).
- Object** A chunk of information stored in the K2000's memory. Programs, setups, keymaps, and samples are all objects. There are several others as well.
- Page** A set of performance or programming parameters which appear as a group in the display. The entry level page for each mode appears when you select the mode. Most other pages are selected with the soft buttons, from within an editor.
- Parameter** A programming feature. The name of the parameter describes the function it controls - transposition, for example. Each parameter has a value associated with it, which indicates the status of the parameter.
- Pixel** A contraction of "picture element." The K2000's display consists of a screen with small square dots (the pixels). Each pixel lets light through or blocks it depending on whether it is receiving an electrical charge. The combination of light and dark dots creates a pattern which you recognize as text or graphics. The K2000's display is 240-by-64 pixels, in other words, 64 horizontal rows, each containing 240 pixels, for a total of 15360 pixels.
- Program** The K2000's basic performance-level sound object. Programs can consist of up to 3 layers (32 layers for programs on the drum channel); each layer has its own keymap (set of examples) and sound-processing algorithm.
- Program Editor** The set of parameters that lets you modify the sound of ROM or RAM programs. Enter the Program Editor by pressing the EDIT button while in Program mode, or any time the currently selected parameter has program as its value.
- RAM** Random Access Memory, one of the two basic types of computer memory. RAM can be both read from and written to. When you load samples into the K2000 you are writing to RAM. Compare ROM.
- ROM** Read Only Memory, one of the two basic types of computer memory. You can retrieve the information stored in ROM, but information cannot be written to it. The onboard sounds of the K2000 are stored in ROM.
- Sample** A digital recording of a sound that can be assigned to a keymap as part of the process of building a program. Samples are stored in ROM (factory-installed) or in RAM (loaded from disk).

- SCSI** Pronounced "skuzzy," this acronym stands for Small Computer Systems Interface. It is simply a standardized form of information exchange which allows any SCSI equipped device to communicate with any other SCSI device. Two or more SCSI devices - they can be computers, hard disks, printers, just about anything that sends or receives information in standardized form - are connected via special cables to their SCSI ports. This configuration is much faster than serial information exchange, the precursor to SCSI.
- Semitone** The standard interval between the twelve notes in the scale. There are twelve semitones to an octave. The interval between C and C# is one semitone.
- Setup** A multi-timbral performance object. A setup consists of three zones, each of which can be assigned its own program, MIDI channel, and control assignments. These assignments control the K2000's operation while in Setup mode, as well as determining the Program Change numbers and controller messages the K2000 sends via MIDI.
- Soft Reset** Returns the K2000 to Program mode without affecting the contents of RAM. Press the +/-, 0, and CLEAR buttons to do a soft reset. IF your K2000 is hung up for some reason, this will usually get take care of the problem. See Hard Reset.
- Switch control** A device which converts motion into discrete on/off signals. A switch control, like the sustain pedal, is either on or off. Compare continuous control.
- Toggle** As a verb, to switch between (usually) two conditions using a device which makes the switch. As a noun, the device which makes the switch. For example, pressing the "View" soft button on the top level Program mode page toggles between small-type and large-type views of the current Program.
- Value** the current setting of a parameter. Each parameter has a range of available values, one of which you select while editing. The Transposition parameter on the Program mode page, for example, has a default value of 0. Change the value to change the parameter's effect on the current program.
- VAST** Variable Architecture Synthesis Technique; the term created by Kurzweil engineers to describe the multi-faceted capabilities of the K2000, which combines sample playback (ROM and RAM), and waveform generation with a broad array of processing functions. This architecture provides preset algorithms created by Kurzweil sound engineers, which include filters, distortion, panning, EQ, waveform oscillators, waveform shaper, hard sync oscillators, amplitude modulation, gain, crossfade, and more.

## SECTION 1

### **Zero Crossing**

Any of a number point in the digital representation of a sound's waveform where the digital signal is neither positive or negative. When looping samples, starting the loop at one of these points will reduce or eliminate the click or change in timbre that can occur in sample loops.



SECTION 1

## 2.0 SETUP AND OPERATIONAL CHECKOUT

### 2.1 VOLTAGE SELECTION

- 2.1.1 The K2000 is equipped with a voltage selector which allows operation on single-phase AC of 100 Volts, 120 Volts, 220 Volts, or 240 Volts. The selector is set at the factory for the AC line voltage most commonly in the country of destination. The setting can be checked by looking at the small panel just to the left of the AC power connector - a white indicator pin is visible in the hole next to the selected voltage.

**WARNING:** Do not attempt to operate the K2000 on any AC voltage other than the one selected - extensive damage to the unit may result!

**WARNING:** CHANGING THE VOLTAGE SELECTOR MAY REQUIRE THE USE OF A DIFFERENT LINE CORD OR ATTACHMENT PLUG, OR BOTH. TO REDUCE THE RISK OF FIRE OR ELECTRIC SHOCK, REFER SERVICING TO QUALIFIED SERVICE PERSONNEL

- 2.1.2 To change the selected voltage:

1. Turn the unit off and remove the AC line cord from the AC power connector.
2. Open the cover of the fuse/voltage select compartment using a small blade screwdriver or similar tool.
3. Pull the voltage selector card straight out of the housing, using the indicator pin (See Figure 2.1 below).
4. Orient selector card so the desired voltage is readable at the bottom.
5. Orient the indicator pin to point up when the desired voltage is readable at the bottom (See Figure 2.2 below).
6. Insert the voltage selector card into the housing with the printed side of the card facing towards the AC power connector, and the edge marked with the desired voltage first.
7. If changing from 100V or 120V to 220V or 240V, or vice-versa, change fuse(s) and fusing arrangement as described under "Fuses"
8. Replace compartment cover. Verify the indicator pin shows the desired voltage.

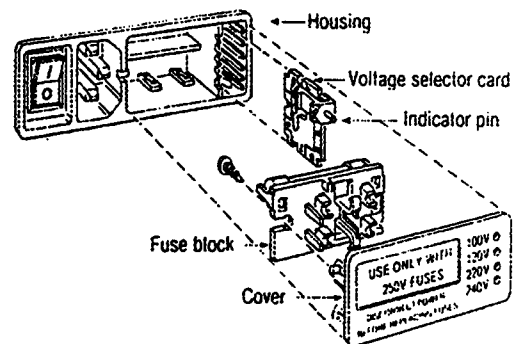

Figure 2.1 - Voltage Selector Card Removal

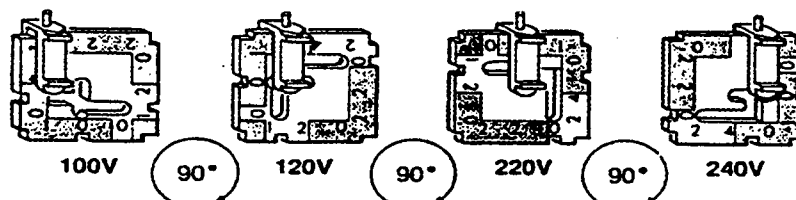

Figure 2.2 - Voltage Selector Card Orientation

## 2.2 FUSES

**WARNING:** FOR CONTINUED PROTECTION AGAINST THE RISK OF FIRE, REPLACE FUSES ONLY WITH THE TYPE AND RATING SPECIFIED.

Fuse Replacement:

- 2.2.1 In **North America** and other locations where the AC supply voltage is 1-- - 120V/60Hz, replace the fuse only with Type AGC, ¼" x 1¼", Fast-Acting, 250 Volt, 1 Amp fuse as per Figure 2.3 below.

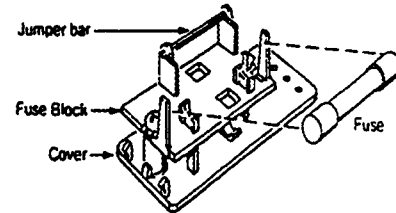

Figure 2.3 - American fuse

- 2.2.2 In **Europe** and other locations where the AC supply voltage is 220 - 240V/50Hz, there are two fuses - wone on Line and one on Neutral. Either of these fuses should be replaced only with a Type GDB, 5mm x 20mm, Quick-Acting (F), Low-Breaking Capacity, 250 Volt, .50 Amp fuse as per Figure 2.4 below.

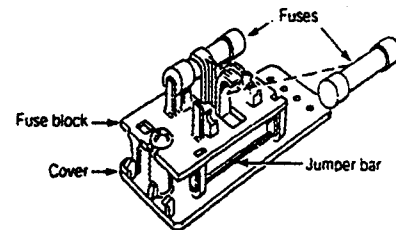

Figure 2.4 - European fuse

**NOTE:** When preparing the unit for use on European or other 220 - 240V/50Hz AC lines, the fusing arrangement must be changed in order to fully protect the instrument.

2.2.3 To change from the North American to the European fusing arrangement:

**NOTE:** Refer to Figure 2.5 below for details.

1. Turn the unit off and remove the AC line cord from the AC power connector.
2. Remove the cover of the fuse/voltage select compartment using a small screwdriver or similar tool.
3. Loosen the Phillips screw 2 turns.
4. Remove fuse block by sliding up, then away from the PHillips screw, and lifting up from the pedestal.
5. Invert the fuse block and install the .50 Amp GDB fuses in both the upper (Hot) and lower (Neutral) holders.
6. Slide the fuse block back onto the Phillips head screw and pedestal.
7. Tighten the Phillips head screw.
8. Replace the cover.

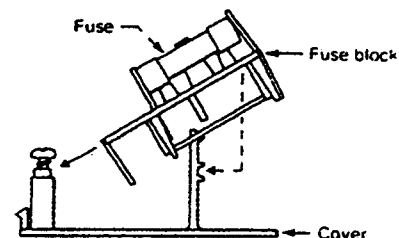

Figure 2.5 - North American to European fuse conversion

**2.3 RAM EXPANSION**

**2.3.1** User RAM in the D2000 may be expanded with the installation of SIMMs (Single In-line Memory Modules) in pairs. SIMMs for the K2000 must be 30 pin, 8 bit, and 120ns or faster, with maximum dimensions not exceeding 3.5" wide x 2.2" high x .25" thick - SIMMs with ICs on both sides are not supported. The following memory sizes are supported:

**256KB x 8    1MB x 8    4MB x 8    16MB x 8**

**2.3.2 Installation of SIMMs:**

1. Turn the unit off and remove the AC line cord from the AC power connector.
2. Open the unit as described in Section 3, "Disassembly".
3. Locate the SIMM sockets on the Engine board (Figure 2.6). There are two banks of SIMM sockets, the two inner sockets are Bank A and the two outer sockets are Bank B. When installing one bank (2 SIMMs), install the SIMMs in the Bank A sockets. When installing two banks (4 SIMMs) of different sizes, make certain the 2 SIMMs in the Bank A sockets are the same size, and the 2 in the Bank B sockets are the same size.
4. Insert a SIMM into the proper socket at a 60 angle (Figure 2.7).
5. Press the SIMM firmly into the socket until it clicks into place.
6. Pull the latches on each end of the socket outward, rotate the SIMM to a vertical position, and release the latches.
7. Repeat steps 3 - 5 to install remaining SIMMs.
8. Once all SIMMs have been inserted, inspect for proper installation - make sure the top edges of all like SIMMs are at the same height and parallel to the printed circuit board.
9. Close the unit as described in Section 3.

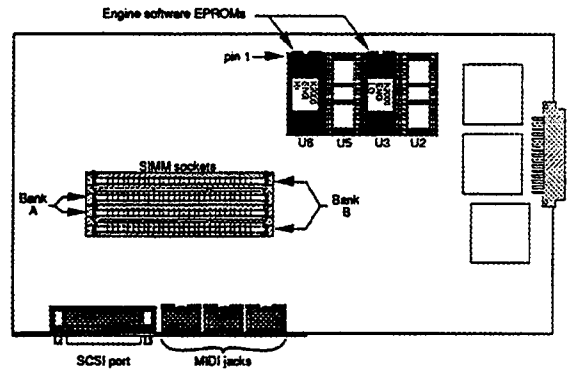

Figure 2.6 - Engine Board memory chip layout

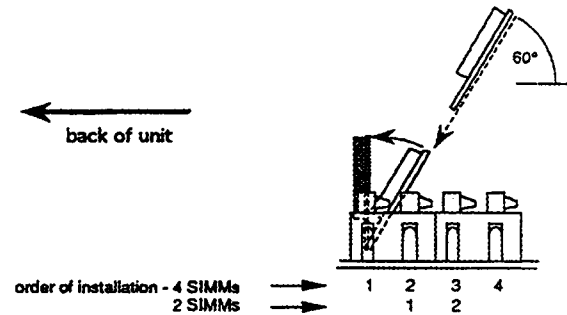

Figure 2.7 - SIMM installation

**2.3.3 To verify the SIMMs are functional:**

1. Plug in the power line cord, and turn the unit on.
2. After the K2000 has initialized, press the "DISK" button.
3. Confirm the "Samples:####K" figure displayed in the center of the status bar corresponds to the total amount of user RAM just installed.

2.4 Changing System Software (Engine)

**NOTE: The ICs containing the K2000's software are static sensitive devices. USE ALL STANDARD ANTI-STATIC PRECAUTIONS WHEN HANDLING THESE DEVICES!**

2.4.1 To replace the ICs:

1. turn the unit off and remove the AC line cord from the AC power connector.
2. Open the unit as described in Section 3.
3. Locate the old software ICs U3 and U6, on the Engine Board (Figure 2.6 above). Remove the old ICs using an IC puller or similar tool. Be careful not to damage the traces on the board.
4. Carefully insert the new IC labeled "LO" in the socket at U3, and the new IC labeled "HI" in the socket at U6. Make certain the ICs are oriented with pin 1 toward the front of the unit. Pin 1 is on the end of the IC with the indentation.
5. Inspect for proper installation - make sure the ICs are firmly seated into the sockets and that none of the pins are bent.
6. Close the unit as per the instructions in Section 3.
7. Always **HARD RESET** the instrument after changing the software. **Note that all user data in RAM will be erased.** A hard reset can be performed on power-up by pressing and holding the "1", "2" and "3" buttons on the numeric keypad.

### 2.5 BASIC STARTUP CHECKLIST

- Make certain the k2000's voltage setting matches the voltage in your location.
- Set the K2000 on a hard flat surface or a stable keyboard stand, and leave plenty of room for ventilation.
- Connect the power cable.
- Make sure the sound system is at a safe volume level.
- Plug in a pair of stereo headphones or run standard (¼ inch) audio cables from the MIX audio outputs to your sound system (use the left MIX output for mono).
- Plug the included foot pedal into the rear panel jack marked "Foot Switch 1".
- Power up the unit and begin playing.
- If distortion is heard, reduce the gain on the mixing board, or use the pad if it has one.
- Scroll through the Program list with the Alpha Wheel (the large knob to the right of the display).
- Press the Setup mode button, then use the Alpha Wheel to select tri-zone setups with independent programs, MIDI channels and controls in each zone.
- Press the Quick Access mode button and use the numeric keys to select from programmable banks of ten programs or setups.
- Insert a program library disk into the floppy drive. Press the Disk mode button, then scroll through the files with the Alpha Wheel. Press "Load", then press "OK" twice. Then check out the programs numbered in the 200s.

### 2.6. STARTUP - THE DETAILS

2.6.1 This section will walk you through the hookup of the K2000. We'll take a look at the rear panel, then describe the power, audio, and other cable connections.

### 2.7 BEFORE STARTING...

2.7.1 Before connecting anything, make certain the K2000 is properly and safely situated. It will rest securely on most standard keyboard and instrument stands. Otherwise, it should rest on a hard flat surface. In this case, it ~~must~~ rest on its rubber feet, and **NOT** on the bottom panel. **NEVER** block the ventilation openings on the rear panel; doing so can cause overheating which will seriously damage the K2000. To provide adequate ventilation, the rear panel should be at least four inches from any vertical surface.

2.7.2 There are no user-serviceable parts in the K2000. Under no circumstances should you attempt to remove any panels, except for battery replacement. Any attempt to open the K2000 by an untrained, unauthorized person will result in risk of electric shock and automatic voiding of the product warranty.

2.8 CONNECTING THE POWER CABLE (LINE CORD)

2.8.1 The K2000 runs on 100V, 120V, 220V, or 240 Volt AC power at 50 - 60 Hz. The voltage level is set with a selector on the rear panel. Your dealer should have set the voltage switch to match the voltage in your area, but it is a good idea to check it. Excessive voltages can seriously damage any electric device. If the voltage selector is not properly set, have your dealer or other qualified service personnel reset it before you use your K2000.

**NOTE TO QUALIFIED SERVICE PERSONNEL:** Instructions for setting the voltage selector are included in Section 2.1 of this manual.

2.8.2 Facing the rear panel of the K2000, the power connector is on the left-hand side. Connect the power cord to the K2000 first, then to a properly grounded three-prong power outlet. If your power source does not have the standard three-prong outlet, you should take the time to install a proper grounding system. This will assure you of avoiding problems with audio hum, and will reduce the risk of a shock hazard.

2.9 AUDIO CONFIGURATIONS

NOTE; Refer to Figure 2.8 below for details on rear panel connections.

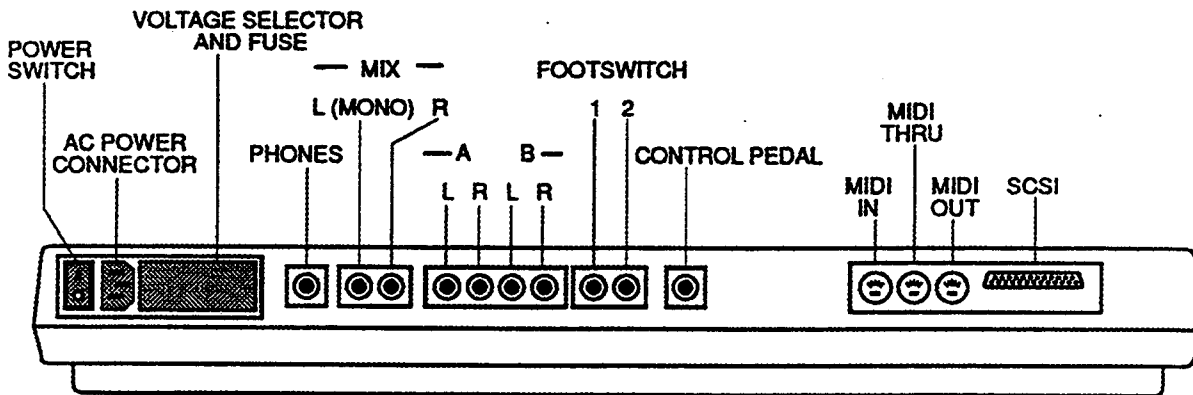

Figure 2.8 - Rear Panel Connection Layout

2.9.1 The K2000 features six audio jacks, enabling you to route the K2000's sounds through its own internal effects processor, through an external effects device, or through combinations of the two. Of course the K2000's effects processor can be bypassed as well.

2.9.2 On the rear panel are a pair of stereo mix jacks (MIX L and R), and four additional jacks - A (L and R) and B (L and R). These can be configured as two stereo pairs or as four separate outputs. Your audio configuration is determined by two factors. The "hardware" side has to do with which jacks you use and what kind of cables you connect to them. The "software" side depends on the

settings you make for parameters on the OUTPUT page in the Program Editor, and on the Master mode page.

- 2.9.3 The simplest configuration would involve connecting the left and right MIX outputs directly to a mixing board or keyboard amplifier. If you're using only one input to your sound system from the K2000, use the left MIX output for a mono signal. We'll assume for now that you're using only the MIX outputs.
  
- 2.10 MIX OUTPUTS
  - 2.10.1 If it is planned to use the K2000's global effects processor to add dimension to the sounds, it will be necessary to use the MIX outputs. The audio output to the separate outputs is always dry - that is, the audio signal is sent to the separate outputs without passing through the global effects processor. The MIX outputs and the headphone jack are the only jacks where the signal will appear with effects.
  
  - 2.10.2 The signal is routed using the OUTPUT page in the Program Editor. While in Program mode, press the EDIT button, then press one of the <more> soft buttons until you see "OUTPUT" on the display's bottom line. Press the corresponding soft button, and the OUTPUT page will appear. Set the value of the Pair parameter to A(FX) if the current layer's sound is to be routed through the effects processor before appearing at the MIX outputs.
  
  - 2.10.3 A value of A(FX) mean two things: first, the layer's sound will appear with effects at the MIX outputs, and second, the layer's sound will appear *without* effects at the Group A outputs if standard audio cables are inserted into the Group A output jacks. Set the value of the Pair parameter to B(DRY) if the layer's sound is to appear without effects at the MIX outputs. It will also appear at the Group B outputs if standard audio cables are inserted into the Group B output jacks. Connecting audio cables to the A or B outputs will remove part or all of the signal from the MIX outputs. Be sure to set the output pair for every layer in the program; each layer can be routed independently (use the CHAN/Bank buttons to scroll through the layers). You'll also want to set the pan position for each layer while you're on the OUTPUT page. Depending on the program you're working with, you'll have several different options for panning. Refer to "THE OUTPUT PAGE" in chapter 6 of the Musician's Guide for details of these options. Also see "PANNER" in Chapter 14 of the Musician's Guide to learn how to gain even more control over a layer's pan position.
  
- 2.11 SEPARATE OUTPUTS
  - 2.11.1 The K2000's four separate outputs are arranged in two pairs, A and B. These are mono output jacks, and you'll normally plug a standard audio cable into one or more of them. Depending on the OUTPUT page settings you use for a given program's layers, they can function as two stereo output pairs, or as four separate outputs.
  
  - 2.11.2 The diagram below illustrates the wiring of the K2000's audio system. From the sound engine, the audio signal can be routed to either the A or B output group. If the signal is routed to Output



Group B, it will appear at the MIX outputs if no audio cables are plugged into the B outputs. Plugging cables into the B outputs will divert the signal from the MIX outputs to the B outputs.

- 2.11.3 If the signal is routed to Output Group A, and audio cables are plugged into the A outputs, the signal will pass directly to the A outputs. If no cables are plugged into the A outputs, the signal will pass from the sound engine to the global effects processor. The left and right sides are mixed before passing to the effects processor. The effects processor splits the signal into left and right sides again after the effects are applied. Effects will be applied to both sides of the signal unless the Out A->FX parameter is set L Only, in which case only the left side will have effects applied. In either case, the signal will pass to the MIX outputs.
- 2.11.4 If a layer's pan position is centered, the outputs to which it's assigned will carry an equal mix of the layer's sound in its left and right outputs. This makes the audio outputs a stereo pair with respect to that layer. If the layer is panned all the way to the left or right, the separate outputs function as individual monophonic outputs with respect to that layer. Of course, you could have a multi-layer program with all its layers assigned to the same output group, and pan each layer so that some of them appear at both outputs, while others appear only at the left or right output.
- 2.11.5 If you are using the K2000 for recording and multi-timbral sequencing, you will need to use the separate outputs to increase the mix down options, and for adding outboard effects to your sounds. The separate outputs give a great deal of added flexibility.

2.12 HARDWARE AUDIO SWITCHING

- 2.12.1 It is important that you understand the effect on the MIX outputs when using the separate outputs. When a standard audio cable is connected to any of the separate outputs, every sound (or part of a sound) that is assigned to the output connected will be removed from the MIX outputs. For example, imagine a cable is plugged into the left output of Group A. The left side of every program layer assigned to Output Group A will disappear from the left side of the MIX outputs, and will appear only at the left Group A output. If a layer is panned all the way left, it will disappear from the MIX outputs entirely. If it is centered, the left side will disappear, but the right side will remain at the right MIX output. A layer that is panned hard right will not be affected in this case. IF you use all four separate outputs, the MIX outputs will not carry any signal.
- 2.12.2 The pan settings made on each program's OUTPUT page apply to the separate outputs just as they do for the MIX outputs. Keep in mind, however, the signal at the separate outputs will always be dry; only the MIX outputs make use of the global effects processor.
- 2.12.3 Once the output groups are assigned on the OUTPUT page, go the Master mode to specify how the signal will appear at the MIX outputs. On the Master mode page are three parameters which affect the routing of all signals that are sent to the MIX

outputs. The settings for these parameters will affect each layer in every program.

- 2.12.4 The parameters Out A->Mix and Out B->Mix determine the panning of the audio signal at the mixed outs. If they are set to Stereo, whatever panning is applied to each program (as set on the OUTPUT page in the Program Editor) will show up at the MIX outputs.
- 2.12.5 If either of these parameters is set to Mono, the programs routed to the corresponding audio output group will send all of their sound at equal levels to both outputs, regardless of any panning that might be applied to them on the OUTPUT page. This is a quick and convenient way to convert the MIX outputs into two mono outputs.
- 2.12.6 The parameter Out A->FX is intended for special cases when you want an additional separate output that does not go through the K2000's effects processor. A value of L Only bypasses the effects processor for all sounds assigned to the right side of Output Group A.
- 2.13 STEREO INSERT CABLES
  - 2.13.1 The preceding description of the separate outputs is only part of the picture. You can make the separate outputs even more useful by using stereo insert cables. A stereo insert has a single stereo plug on one end; the other end is split into two mono cables fitted with mono plugs. By plugging the stereo end of a stereo insert cable into one or more of the K2000's separate outputs, many audio configurations with outboard gear can be created. The tip of the stereo end carries the signal to the send side of the split end, and the ring of the stereo end receives the signal from the return side.
- 2.14 EFFECTS RETURN
  - 2.14.1 Plug the stereo end of a stereo insert cable into one of the K2000's separate outputs, then plug the send side of the split end into an input on an outboard effects box. If you connect the effects box's output to the return side of the split end, you've created a loop that will send the K2000's output into the effects box, and return it wet to the K2000. Since the loop returns the signal to the same output jack on the K2000, the K2000's MIX outputs act as if there were no cable at all plugged into the separate output, and the signal will appear at one or both of the MIX outputs. If you are using one of the Group A outputs, you can apply the effect of both the outboard box and the K2000's global effects processor to the corresponding side of the K2000's MIX outputs. IF you do not want to double the effects in this way, go the Effects mode, set the FX mode parameter to Master, and set the Wet/Dry Mix parameter to 0%. Also, you can set the Pan parameter of programs routed to Output Group A fully right, then go to Master mode and set the Out A->Mix parameter to mono, and the Out A->FX parameter to L Only. This will send programs routed to Output Group A to the MIX outputs without going through the K2000's effects processor, but will still send the signal to both the left and right MIX outputs.

## SECTION 2

STARTUP.DOC 12/22/92

### 2.15 INPUT TO K2000

- 2.15.1 Plug the stereo end of an insert cable into one of the K2000's separate outputs, then connect the return side of the split end to the audio output of another instrument. This will route the other instrument's output to the K2000. You can leave the send side unconnected. The output from the other instrument will appear at the K2000's MIX outputs, along with any sounds from the K2000 that are routed to the MIX outputs. If the insert cable is plugged into the A LEFT output, the K2000's effects will be applied to the signal, unless the Out A->FX parameter is L Only, in which case the K2000's effects will not be added to the signal. If the insert cable is plugged into the A RIGHT output, the K2000's effects will be added regardless of the setting of the Out A->FX parameter.

2.16 K2000 POWER-UP CHECK OUT

2.16.1 VISUAL:

- Inspect unit for signs of damage or omissions.
- Verify the correct power entry module is configured for proper AC voltage.
- USA units should have white nylon dot in the 120 volt positions.
- When converting to another voltage; fuse value may require change.
- (Refer to appendix 4 of Musicians Guide)

2.16.2 POWER UP:

- Normal sequence is: LCD back light comes on.
- All eight LEDs blink in unison once.
- LCD displays "Welcome" message.
- Program mode LED lights and LCD displays Program mode data.
- (Refer to chapter 2 of Musicians Guide)

2.16.3 LEDs BLINK TWO TIMES:

- If the Pitch Wheel range is not within 120 to 136 range.

2.16.4 LEDs BLINK THREE TIMES:

- If the battery voltage is below 3.2 volts.
- Note that scanner also reports a low voltage to the engine board which will display low voltage.

2.16.5 POWER ON DIAGNOSTICS:

- Power on diagnostics are limited. The engine board checks a few locations in non-volatile RAM, (program RAM) to determine whether to use stored data or regenerate factory defaults.
- The effects processor performs basically the same type tests for its non-volatile RAM.

2.16.6 SCANNER DIAGNOSTICS:

- Test digital circuits portion of audio/power supply board (appendix A1-3).
- To enter this mode, press buttons 4, 5, and 6 together. The eight LEDs should blink in order and the display will display "K2061 Scanner..." etc.

2.16.7 BATTERY VOLTAGE:

- 4.2 Volts, three penlight cells (AA size). Typically 4.2 to 4.3 volts.
- Less than 3 volts, replace batteries or correct wire connection.

2.16.8 WHEEL CENTER:

- A minimum of 120 to a maximum 135, 127 or 128 is mid-point. Moving the pitch up or down should

result in its return to center value plus or minus one.

- Note: the pitch bend off zone or zero window created in software is wider than this value.

These values are arbitrary and do not equal MIDI values, although these values are used to create the MIDI value through software programming, (e.g. a 129 pitch wheel center value read during power up, would equal pitch bend 64, and if pitch bend center was 104 at power up it would still equal a pitch bend value of 64).

2.16.9 WHEEL AND SLIDE TESTS:

- Move each control up and down and the display should list what the control is and a value that should range from 0 down, 255 up.

2.16.10 ALPHA WHEEL:

- Spin the knob. It should indicate 0, 1, 2, 3, 0, 1, 2, 3, etc., when rotated clockwise.

2.16.11 BUTTON TESTS:

- Press each button and the LCD should display function of each button.
- Mode buttons will also blink their respective LEDs.

2.16.12 KEY TESTS:

- Press the Hi C key. The LCD will display "KEY C7 96 C7 96".
- Translation; the first of two key contacts makes about one half travel and is identified as a "C" key, 7th octave which is MIDI note 96. The second contact makes near the end of travel and is also a "C" key, 7th octave, MIDI note 96. Each key press will be correctly identified by note, octave, and pitch.

2.16.13 MONO PRESSURE TESTS:

- A.K.A. after touch or second touch. Press each key to down and you will feel a resistance at the down stop position. Pressing harder will compress the down stop which is a pressure sensitive variable resistor strip.
- The LCD will display PRESSURE = nnn(0 = minimum and 255 = maximum).

2.16.14 PEDAL TEST:

- Insert a pedal cable plug into pedal jack 1 or 2, the LCD will display pedal 1 or 2.
- Insert control pedal into its jack, the LCD will display CONTROL PÉDAL = nnn(0 = minimum and gradually increase to 255 = maximum) as the pedal is depressed.

TO EXIT SCANNER DIAGNOSTICS, PRESS "EXIT" AND "ENTER" TOGETHER.

- 2.17       SOUND TEST:
  - Plug in stereo headphones or a two channel sound system and continue below.
  
- 2.17.1     SOUND ROMs:
  - Select each voice as indicated; play 1 note, then play a chord. Allow each to decay completely, (approximately 10 seconds). Listen for correct sounds.
  
  - Select voice 31 Classical Piano
  - Select voice 120 Warm Choir
  - Select voice 183 Warm Bell
  - Select voice 85 Wood Bars
  
- 2.17.2     EFFECTS QUALITY:
  - With Wood Bars still selected, press the Effects mode button and set wet/dry to zero (0) %, play as above and listen to effects.
  - Set effects to 50% wet, play and listen again.
  - Set effects to 100% wet, play and listen again. With 100% wet, noise floor will raise slightly (see Chapter 9 of Musicians Guide)
  
- 2.17.3     EFFECTS OFFSET:
  - Switch the effect between 106 Into The Abyss and 107 Space Flange.
  - A small artifact maybe present during switching or in the background of the flange effect. Note that setting the offset adjustment to a null point for the pop artifact may increase the noise floor. Check also for background artifact on the flange effects as a change to the offset adjustment can also add this artifact. Set for best overall performance.
  
- 2.17.4     CALVIN TEST:
  - NOTE: 24 layers must be created for this test.
  - Select voice 116, Solo Flute. Press EDIT, then change EQ to none.
  - Move cursor to AMP block, press enter and change adjust to -6db.
  - Press KEYMAP then 153, ENTER (very dull saw).
  - Press right MORE twice.
  - Press EFFECT, set wet/dry to 0%.
  - Press COMMON and change the pitch bend range to 2400 ct.
  - Press right MORE four times.
  - Press DupLyr 23 times to create 24 duplicate layers.
  - Play a note and move the pitch bend wheel up and down slowly. The transition should be smooth with no glitches. Note that it is possible to hold the wheel between increments and the system will switch

back and forth, this is normal. (Save this setup to disk for future use.)

2.17.5 OUTPUT JACK TEST:

- Select program 31 Piano or any single layer program. Plug headphone or single output device into LEFT mix jack, listen for proper output.
- Used with a mono device, the LEFT jack is left plus right output signal.
- Plug headphone into RIGHT output mix jack. Listen for proper output.
- Used with a mono device, RIGHT jack is mono only and will be about 3db lower than left when used alone.

2.17.6 OUTPUT JACK A:

- The output from this jack should sound the same as the mix jack output, except there are no "effects" and the volume fader does has no influence.

2.17.7 OUTPUT JACK B:

- Press EDIT, MORE twice, then press output once. Change PAIR: A(FX) to PAIR: B(DRY) by pressing "+" once.
- B jack will now output the piano without "Effects" or "volume fader".
- To exit, press EXIT, then NO (button F). Returns to default settings.

2.17.8 MIDI JACK TEST:

- Feed a MIDI signal into the MIDI IN jack. This MIDI signal should appear at the THRU jack.
- Play the keyboard and test MIDI OUT jack by sending MIDI signal into another instrument.
- Note: you can display MIDI data on the LCD. Press MASTER, then UTILITY, then MIDI, and read data on the LCD. (See chapter 10 in the Musicians Guide.)

2.17.9 DISK DRIVE:

- Insert a demo or program diskette. Press DISK, then LOAD, then OK twice.
- Press SONG or PROGRAM and verify that disk data and functions were loaded. Play the keyboard.

USE A SPARE DISKETTE FOR THIS TEST: data will be erased.

- Verify all tracks can be written to and read from.
- Insert 1.44M (HD) diskette, press DISK, then FORMAT, then YES, then 1.44M, then YES twice. (See chapter 13 in Musicians Guide.)
- Note: 1.44M HD diskettes can be easily identified by the presence of a second square hole opposite the write protect hole. 720K diskettes have only the write protect hole.

- 2.17.10 ENGINE DIAGNOSTICS:
- This tests the Engine circuits, disk drive(s), sound ROMs, SIMMs, etc.

**DIAGNOSTICS WITH SOFTWARE VERSION 1.00**

- With AC power off, open the battery compartment located in the bottom of the case and remove one battery. Wait 2 minutes; replace the battery and compartment cover.
- Turn on the AC power, the LCD should display HARD RESET/DIAGNOSTICS.
- Move the cursor to DIAGNOSTICS, then press ENTER.

**DIAGNOSTICS WITH SOFTWARE VERSION 1.1x.**

- With AC power off, press and hold buttons 1, 2, 3, then switch AC power on.
- The LCD should display HARD RESET/DIAGNOSTICS.
- Move the cursor to DIAGNOSTICS, then press ENTER.

- 2.17.11 DIAGNOSTICS TESTS:

- The tests are mostly self-explanatory. Following the LCD display prompts, general knowledge will guide you through the tests.

- 2.17.11.1 INDIVIDUAL TESTS:

- Move the cursor to the desired test and press ENTER. The test will run once and the LCD will display "SUCCESS" or "ERROR DATA".
- EXP is for expected data.
- OBS is for observed data expressed in hexadecimal.

- 2.17.11.2 ALL TEST:

- Press "A" button under display. All tests in the menu will run continuously until interrupted by pressing EXIT.
- Press "B" button under display. The test selected from the menu will run until interrupted by pressing EXIT.

**NOTE: SET-UP AND EXCEPTIONS:**

1. A formatted 1.44M diskette should be inserted in drive or test will hang-up at this point.
2. SCSI test will always fail without internal or external drive installed.
3. SCSI individual test without drive: LCD will display "Testing... not found".
4. Sound ROM and RAM tests are difficult to read in all test mode because these tests are very quick and test jumps to LCD to quickly to interpret ROM/RAM results. Reading summary at bottom of LCD at the end of the test, you can interpret the results as follows:



## SECTION 2

FWRCHECK.DOC 12/22/92

- Total (test passes) 5, minus failures 5 (SCSI failures) = 0.  $5 - 5 = 0$ .
  - Assuming no hard drive installed, this tells you all ROM/RAM passed.
5. Alternate test: Run individual test on each ROM/RAM, if desired.

**2.18 K2000R STARTUP****2.18.1 Startup - a Quick Checklist**

If hooking up new gear is familiar to you, and you just want to get going, here is a quick description of all the basic things you need to cover to get started with your K2000R. If you need more information, thorough descriptions of each step follow.

**2.18.2 Basic Startup Checklist**

- Mount your K2000R securely in a standard 19-inch MIDI rack, or set it on a hard flat surface. Make certain to provide adequate ventilation room above and below the unit.
- If placing on a flat surface, affix the four pads (included with the rack mount brackets) to the bottom of the K2000R, one in each corner.
- If rack mounting, attach the rack mount brackets, one to each side, at the front edge of the unit using the screws already on each side.
- Connect the power cable.
- Make sure your sound system is at a safe volume level.
- Plug in a pair of stereo headphones or run standard (1/4 inch) audio cables from the MIX audio outputs to your sound system (us the MIX L out for mono).
- Connect a MIDI cable from the MIDI Out port of your MIDI controller to the MIDI In port of the K2000R.
- Power up and play.
- If you hear distortion, reduce the gain on your mixing board, or use the pad if it has one.
- Scroll through the Program list with the Alpha Wheel (the large knob to the right of the display).
- If you MIDI controller can transmit on more than one MIDI channel, check out Setup mode by pressing the Setup mode button. Then use the Alpha Wheel to select tri-zone setups with independent programs, MIDI channels and controller assignments in each zone.
- Press the Quick Access mode button and use the numeric keys to select form programmable banks of ten programs or setups.
- Insert a program library disk into the floppy drive. Press the Disk mode button, then scroll through the files with the Alpha Wheel. Press "Load," then press "OK" twice. Then check out the programs numbered in the 200s.
- If you do not hear any sound, review these steps, then check the Troubleshooting section in Section 4.

**2.18.2 Startup - the Details**

This section will walk you through the hookup of your K2000R. First a look at the rear panel, then describe the power, audio, and other cable connections.

**2.18.3 Before You Start**

Do not connect anything until you make sure your K2000R is properly and safely situated. You will probably be mounting it in a standard 19-inch MIDI rack (it takes up three rack spaces). Otherwise, it should rest on a hard flat surface. In this case, it **must** rest on its rubber feet (supplied in the packing carton), and **NOT** on the bottom panel. **NEVER** block the ventilation openings on the bottom or rear panels; doing so can cause overheating and serious damage. To provide adequate ventilation, the rear panel should be at least four inches from any vertical surface.

There are no user serviceable parts in the K2000R. Under no circumstances should any attempt be made to remove any panels (except for battery replacement - see Section 4) by unqualified personnel. To do so risks electric shock and may void the warranty.

**2.18.4 The Rear Panel**

Refer to Figure 2.9 below for details throughout this section.

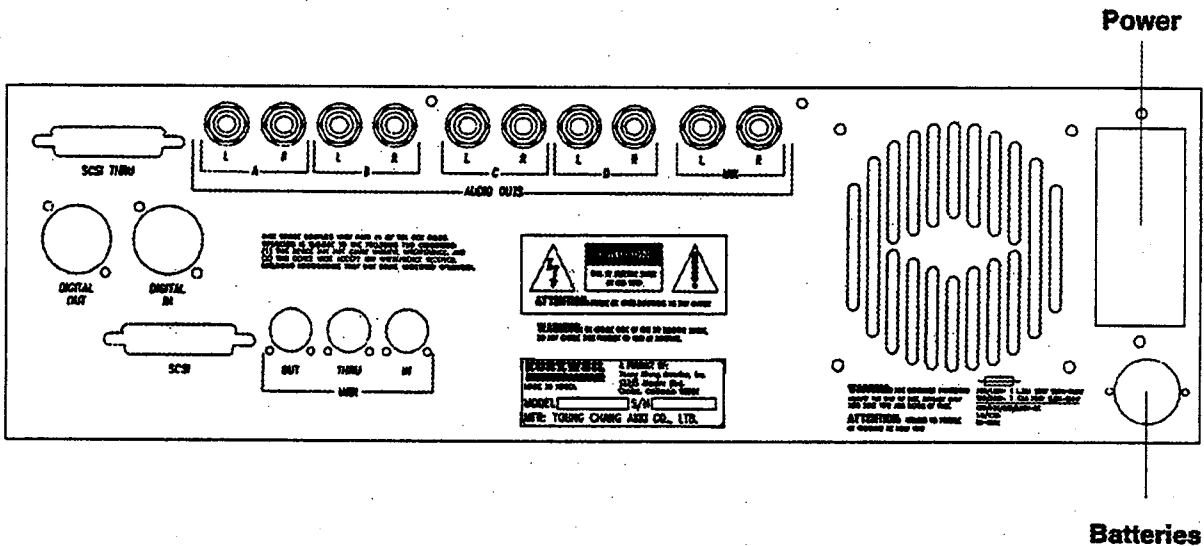

Figure 2.9 - K2000R Rear Panel

The K2000R runs on 100, 120, 220, or 240 volt AC power at 50 - 60 Hz. The voltage level is set with a selector on the rear panel. The voltage is normally set to the country of destination. If the voltage selector is not properly set, have a qualified technician, or your Kurzweil dealer, reset it.

**NOTE TO QUALIFIED SERVICE PERSONNEL: INSTRUCTIONS FOR SETTING THE VOLTAGE SELECTOR APPEARS LATER IN THIS SECTION.**

As you face the rear panel of the K2000R, the power connector is toward the right hand side. When you have connected the cable at the K2000R end, plug it into a grounded outlet (three hole). If the power source does not have the standard three hole outlet, take the time to install a proper grounding system. This will assure of avoiding problems with audio hum, and will reduce the risk of a shock hazard.

### **2.18.5 Connecting the Audio Cables**

After you have turned down the level on your sound system, you can rig the K2000R's audio connections. You will find ten 1/4-inch jacks near the top of the rear panel. For now, connect mono audio cable to each of the jacks marked MIX L and R. Connect the other end of each cable to your mixing board or PA system inputs. If you have only one input available, use the K2000R's MIX L output to get the full signal in mono.

Refer to Chapter 18 of the K2000R Musicians Guide for more detailed information about the audio configuration.

### **2.18.6 Connecting MIDI**

The simplest MIDI configuration uses a single MIDI cable, from the MIDI Out port of your MIDI controller to the MIDI In port of the K2000R. There are all sorts of possible configurations, including additional synths, personal computers, MIDI effects processors, and MIDI patch bays. Depending on your system, you may want to use the K2000R's MIDI Thru port to pass MIDI information from your MIDI controller to the K2000R and on to the next device in your system. You can also connect MIDI devices to the K2000R's MIDI Out port, which can send channeled MIDI information from your MIDI controller. See the discussion of the Local Keyboard Channel parameter in Chapter 10 of the K2000R Musicians Guide.

NOTE: A quick check of the K2000R and the audio system can be performed without a MIDI controller connected to the K2000R. Hold down the CANCEL button on the alphanumeric pad and press any other alphanumeric button. If all is well, you will hear notes. Refer to Appendix 1 of the K2000R Musicians Guide for more information about this feature.

### **2.18.7 Connecting SCSI**

When connecting a hard disk or other SCSI device to the K2000R, read the following information carefully; it is very important.

**IMPORTANT NOTE:** A single SCSI device may be connected to either SCSI port. When connecting more than one SCSI device to the K2000R (including an Apple Macintosh™ computer) the SCSI chain **MUST** be terminated properly. Refer to Chapter 13 of the K2000R Musicians Guide, specifically the section labeled "SCSI Termination" for details. If the SCSI ports are not properly terminated, data can be lost and/or the K2000R and SCSI devices may be damaged.

2.18.8 Switching On the Power

The power switch is located at the lower left of the front panel. When you power up, the display will briefly say "Welcome to the K2000R!" The Program Mode display will then appear. It looks like Figure 2.10 below (the programs shown in the diagram do not necessarily exist):

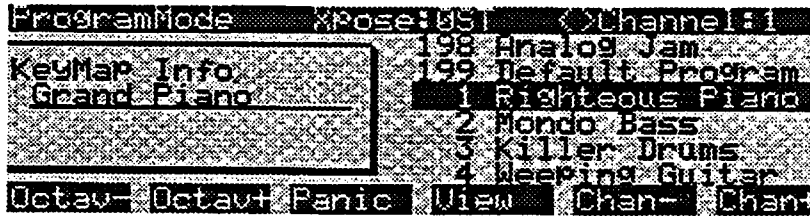

Figure 2.10 - Program Mode Display

Set the volume at a comfortable level. You will get the best signal-to-noise ratio if you keep the K2000R at full volume (turn the volume knob fully clockwise), and adjust the level from your mixing board. You may also want to adjust the display contrast. This is done with the Contrast parameter in Master mode. See Chapter 11 of the K2000R Musicians Guide. As you trigger notes from your MIDI controller, you will see the MIDI LED flash. If it does not flash, check you MIDI cables and connections.

**2.19 K2000R VOLTAGE SELECTION**

The K2000R is equipped with an internal voltage selector which allows operation on single-phase AC mains of 100 volts, 120 volts, 220 volts, or 240 volts. The selector is set at the factory for the AC line voltage most commonly used in the country of destination.

**WARNING: Do not attempt to operate the K2000R on any AC voltage other than the one selected - extensive damage to the unit may result!**

**WARNING: CHANGING THE VOLTAGE SELECTOR MAY REQUIRE THE USE OF A DIFFERENT LINE CORD OR ATTACHMENT PLUG, OR BOTH. TO REDUCE THE RISK OF FIRE OR ELECTRIC SHOCK, REFER SERVICING TO QUALIFIED SERVICE PERSONNEL.**

**2.19.1 To Determine the Voltage Setting**

Locate the clear plastic cover over the fuse in the power module just below the AC connector. Look through this cover onto the surface of the Voltage Selection Card; you will see a three digit number exposed; this number will be 100, 120, 220 or 240 and it indicates the voltage the K2000R is set for.

**2.19.2 To Change the Selected Voltage**

- Turn the unit off and remove the AC line cord from the AC power connector.
- Locate the Voltage Selector Card which is mounted to the AC entry module directly beneath the AC connector.
- Slide the clear cover up and over the AC connector. NOTE: This will not slide up unless the AC cord is removed from the connector.
- Locate the small Voltage Selection card (PC board, approximately 1 1/4" x 3/4") inserted edgewise next to the fuse remover lever. Now locate the hole used to insert a removal tool (1/8" diameter).
- Using a scribe, small screwdriver or other suitable tool, insert same into the hole and apply pressure outward (away from the rear of the K2000R); the Voltage Selection will pull straight out. Take care not to snag the card on the fuse removal lever.
- Reposition the Voltage Selector Card such that when reinserted the proper voltage number appears, insert the card, and press fully home.
- If changing from 100V or 120V to 220V or 240V, or vice-versa, replace the fuses as described under "Fuses" later in this section.
- Close the clear cord and reconnect the AC Cord.

2.20 K2000R FUSES

**WARNING: FOR CONTINUED PROTECTION AGAINST THE RISK OF FIRE, REPLACE FUSES ONLY WITH THE TYPE AND RATING SPECIFIED.**

2.20.1 Fuse Replacement

The fuse compartment is located in the power module and directly beneath the AC connector, under a clear cover. The fuse can be inspected through this cover.

2.20.2 To replace a fuse:

- Disconnect the AC line cord.
- Slide the clear plastic cover up (over the AC connector)
- Locate the Fuse Removal Lever labeled "Fuse Pull" and raise this lever until the adjacent fuse is free of its clip mount. Remove the fuse.
- Insert the new fuse and press completely into the clip mount.
- Close the clear plastic cover and reconnect the AC power cord.
- Test the unit for proper operation.

**IMPORTANT INFORMATION**

In North America and other locations where the AC mains supply voltage is 100 - 120V/60Hz, replace the fuses only with:

Type GMC, 5mm x 20mm, Time-Delay, 250 Volt, 1.25 Amp fuse

In Europe and other locations where the AC mains supply voltage is 220 - 240V/50Hz, replace the fuses only with:

Type GDC, 5mm x 20mm, Type T (Time-Lag), Low-Breaking Capacity, 250 Volt, .63 Amp fuse

## 2.22 K2000R RAM EXPANSION

Sample RAM in the K2000R may be expanded with the installation of SIMMs (Single In-line Memory Modules) in pairs. SIMMs for the K2000R must be 30 pin, 8 bit, and 120ns or faster, with maximum dimensions not exceeding 3.5" wide x 1.75" high x .25" thick. The following memory sizes are supported:

256K x 8    1MB x 8    2MB x 8    4MB x 8    8MB x 8    16MB x 8

### 2.22.1 Installation of SIMMs

**Note: SIMMs are static sensitive devices.**

**USE ALL ANTI-STATIC PRECAUTIONS WHEN HANDLING SIMMs!**

- Turn the unit off and remove the AC line cord from the AC power connector.
- Open the unit as described in Section 3 of the Service Manual.
- Locate the SIMM sockets on the Engine board (as per Figure 2.11 below). There are two banks of SIMM sockets, the two inner sockets are bank A, and the two outer sockets are bank B. When installing one bank (2 SIMMs), install the SIMMs in the bank A sockets. When installing two banks (4 SIMMs) of the different sizes, make sure that the 2 SIMMs in the bank A sockets are the same size, and the 2 in the bank B sockets are the same size.

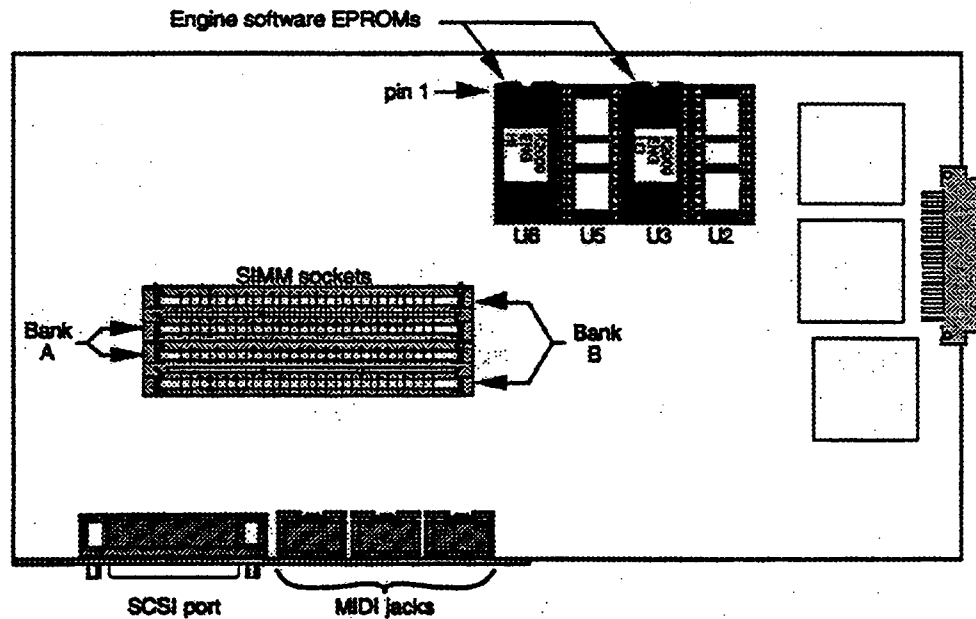

Figure 2.11 - Engine Board Chip Layout



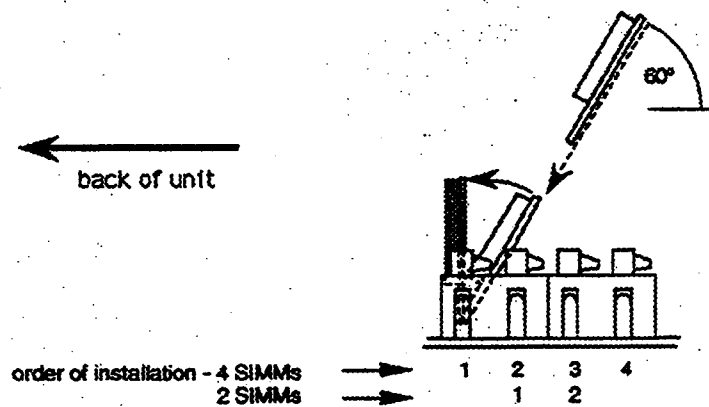

Figure 2.12 - SIMM Installation

- Insert a SIMM into the proper socket at a 60° angle (Figure 2.12).
- Press the SIMM firmly into the socket until it clicks into place.
- Pull the latches on each end of the socket outward, rotate the SIMM to a vertical position, and release the latches.
- Repeat the above three steps to install remaining SIMMs.
- Once all SIMMs have been inserted, inspect for proper installation - make certain the top edges of all like SIMMs are at the same height and parallel to the printed circuit board.
- Close the unit as describe in Section 3 of the Service Manual.

#### 2.22.2 To verify the SIMMs are functional:

- Plug in the power supply line cord, and turn the unit on.
- Once the unit has initialized, press the "DISK" button.
- Confirm the "Samples:####K" figure displayed in the center of the status bar corresponds to the total amount of sample RAM installed in the unit.

**2.23 CHANGING THE K2000R SYSTEM SOFTWARE**

Note: The ICs containing the K2000R's software are Static sensitive devices.  
USE ALL ANTI-STATIC PRECAUTIONS WHEN HANDLING THESE DEVICES!

2.23.1 To replace the ICs:

Turn the unit off and remove the AC line cord from the AC power connector.

Remove the cover as described in Section 3 of the Service Manual.

Locate the old software ICs - U3 and U6 on the Engine board (Figure 2.11). Remove the old ICs using an IC puller or similar tool. Be careful not to damage the traces on the Engine board.

Carefully insert the new IC labeled "LO" in the socket at U3, and the new IC labeled "HI" in the socket at U6. Make sure the ICs are oriented with pin 1 towards the front of the unit. Pin 1 is on the end of the IC which has the indentation in the middle. Inspect for proper installation - make sure the ICs are firmly seated into the sockets and that none of the pins of the ICs are bent.

Replace the cover as described in Section 3 of the Service Manual.

Always **HARD RESET** the instrument after changing the software. Note that all user data in RAM will be erased. A hard reset can be performed on power-up by pressing and holding the "1", "2", and "3" buttons on the numeric keypad while turning on the power switch. Continue to hold the buttons until a message appears in the display.

NOTES

3.0 DISASSEMBLY/ASSEMBLY INSTRUCTIONS

**DISCONNECTED AND ALL STANDARD ANTI-STATIC ELECTRICITY PRECAUTION: PRIOR TO OPENING THIS UNIT IT IS IMPERATIVE THAT POWER BE DECAUTIONS BE EMPLOYED. ANY DEVIATION FROM PROFESSIONAL AND PROPER TECHNIQUES CAN RESULT IN A VOIDED WARRANTY.**

3.1 ENCLOSURE SHELL

3.1.1 It is necessary to open the shell in virtually all instances involving service. This procedure is simple and should be easily remembered.

3.1.2 Place K2000 upside down on clean, smooth, padded surface. CARE MUST BE TAKEN TO POSITION THE UNIT SO AS TO PROTECT THE WHEELS FROM DAMAGE! Using a #2 Phillips screwdriver, remove the six (6) machine screws securing the bottom half of the shell to the top - one in each corner and two near the center of the bottom. Carefully lift the bottom half and place in a safe location until reassembly.

Refer to figures 3.1.1 and 3.1.2 for layout details.

NOTE: You may find a higher comfort level in placing the keyboard away from your body thereby locating the major assemblies closer.

3.1.3 To reassemble, simply reverse the procedure in 3.1.2 above.

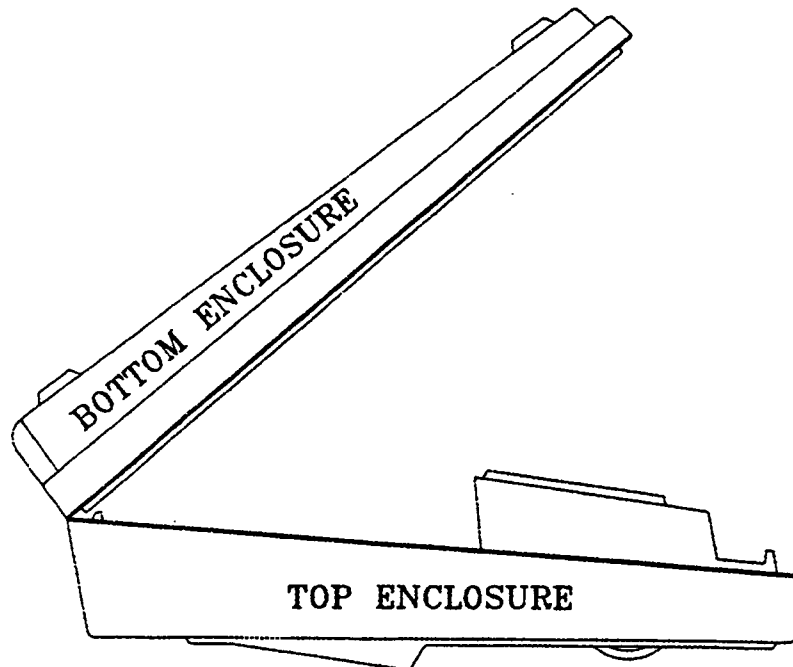

Figure 3.1.1 Enclosure opening detail

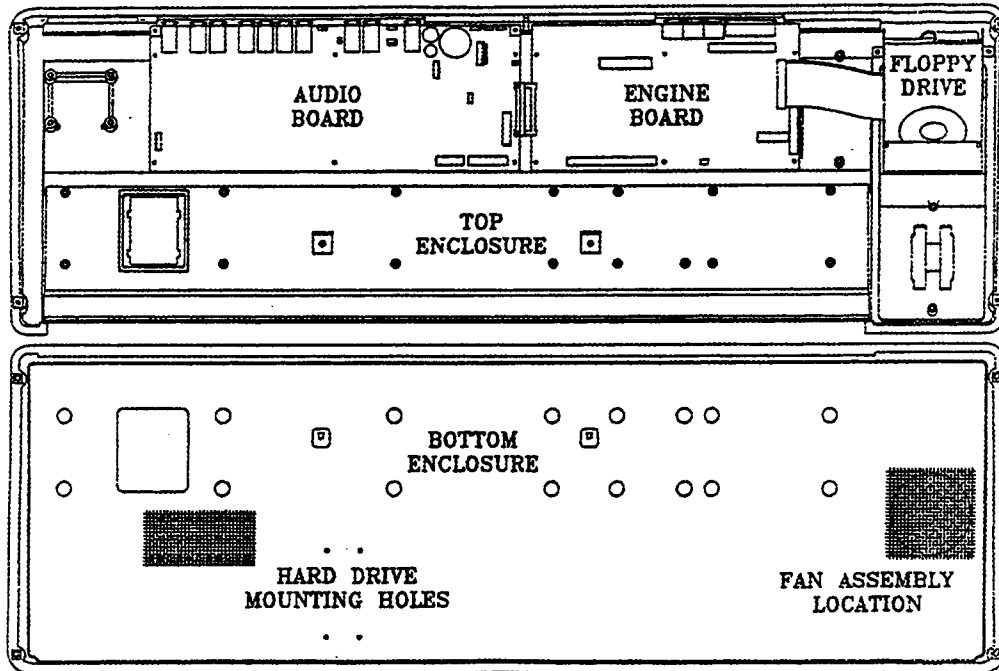

Figure 3.1.2 K2000 layout detail

### 3.2 — ENGINE OR AUDIO/POWER BOARD REMOVAL

- 3.2.1 The Engine and Audio/Power boards are both attached to a metal chassis and are removed as a unit using the following procedure. To deviate from this procedure may place either board into danger of damage from excess flexing; thus, use caution and be mindful of any risks you choose to take. It is necessary to remove this unit before accessing the LCD, Slider and Front Panel boards.
- 3.2.2 Disconnect all connectors from both the ENGINE and AUD/PWR boards. Using a #2 Phillips screwdriver, remove twelve (12) self-tapping screws securing both boards (six for each board). Carefully lift the assembly (consisting of both boards and the metal chassis) from the unit. At this point either board can be removed and/or exchanged.
- 3.2.3 To reassemble, reverse the procedures in 3.2.2 and 3.2.1 above.
- 3.2.4 ENGINE BOARD REMOVAL
- 3.2.4.1 Position metal chassis such that the boards are upside down on a clean, flat surface. Locate and remove the two (2) machine screws securing the Engine board connector panel to the chassis. Carefully grip the chassis and Engine board while repositioning right side up. Now the Engine board can be removed by gently unplugging it from the AUD/PWR board.
- 3.2.4.2 Reassembly is the opposite of 3.2.4.1 above.

## Section 3

KURZASSM.DOC 12/22/92

- 3.2.5 AUD/PWR BOARD REMOVAL
  - 3.2.5.1 Removal of this board is the same as 3.2.4.1 above except there are ten (10) machine screws securing the connector panel to the metal chassis.
- 3.2.6 SLIDER BOARD REMOVAL
  - 3.2.6.1 Before removing bottom of shell, remove slider knobs.
  - 3.2.6.2 Remove bottom of shell as per 3.1.2 above.
  - 3.2.6.3 Remove ENGINE - AUD/PWR unit as per 3.2.2 above.
  - 3.2.6.4 Using figure 1 for reference, locate the slider board between the Front panel and disk drive. Remove the single self-tapping screw and the board is free.
  - 3.2.6.5 Reverse 3.2.6.4 for reassembly.
- 3.2.7 LCD REMOVAL
  - 3.2.7.1 Remove bottom of shell as per 3.1.2 above.
  - 3.2.7.2 Remove ENGINE - AUD/PWR unit as per 3.2.2 above.
  - 3.2.7.3 The LCD board is surrounded by the Front Panel board. Remove the four (4) self-tapping screws securing the LCD and lift the board free.
  - 3.2.7.4 Reverse 3.2.7.3 to reinstall.
- 3.2.8 FRONT PANEL REMOVAL
  - 3.2.8.1 Before removing the bottom half of the shell, remove the round knob on the Front Panel. Also removing the retaining nut and washer under this knob.
  - 3.2.8.2 Remove bottom of shell as per 3.1.2 above.
  - 3.2.8.3 Remove ENGINE - AUD/PWR unit as per 3.2.2 above.
  - 3.2.8.4 Remove the nine (9) self-tapping screws securing the Front Panel and carefully lift panel from instrument. NOTE: This board can be easily damaged by careless handling. BE CERTAIN TO USE CAUTION WHEN HANDLING THIS BOARD.
  - 3.2.8.5 Reverse 3.2.8.4 above to reinstall the Front Panel board. Be certain to remember to use the ninth screw to secure the bracket (used for clamping the cables) in the center front of the panel.
- 3.2.9 POWER TRANSFORMER AND POWER RECEPTACLE REMOVAL
  - 3.2.9.1 Remove bottom of shell as per 3.1.2 above.
  - 3.2.9.2 Note that the Power Transformer and Power Receptacle are hard-wired as a unit. The harness from the secondaries of the transformer are routed to J20 on the AUD/PWR board; thus, can be easily removed from the instrument.

## Section 3

KURZASSM.DOC 12/22/92

- 3.2.9.3 Remove the four (4) machine screws securing the transformer to its posts. Using a 7/32" nutdriver and a #2 Phillips screwdriver, remove the two (2) nuts from the screws securing the Power Receptacle to the back of the shell. Finally, remove the self-tapping screw securing the green wire to the GND terminal on the AUD/PWR board and unplug the harness connector from J20.
- 3.2.9.4 Reverse 3.2.9.3 and 3.2.9.2 above for reinstallation.
- 3.2.10 DISK DRIVE REMOVAL
- 3.2.10.1 Remove bottom of shell as per 3.1.2 above.
- 3.2.10.2 Remove ribbon connector from J10 on ENGINE board. Remove disk drive power connector from J11 on ENGINE board. Remove two (2) self-tapping screws securing aft end of disk drive mounting bracket to shell. Disk drive will now lift out of shell.
- 3.2.10.3 Reverse 3.2.10.2 to reinstall disk drive.
- 3.2.11 KEYBOARD REMOVAL
- 3.2.11.1 Remove bottom of shell as per 3.1.2 above. Orient the K2000 such that the keyboard is facing you and the unit is bottom side up.
- 3.2.11.2 Disconnect ribbon connectors from J2 and J3 on the Audio/Power board (located in the lower right hand corner of the board).  
- Locate the Wheels Interface board in the lower right hand corner of the unit and disconnect the 4-pin ribbon (mylar) connector; this connector may be blue in color.
- 3.2.11.3 Open the battery cover and remove the three batteries. Using a small flat blade screwdriver, or similar tool insert into the retaining clips of the battery box while gently lifting it out of the keyboard enclosure. BE CAREFUL NOT TO BREAK EITHER OF THE TWO WIRES CONNECTING TO SAME. Lay this battery box aside; do not disconnect any wires. See figure 3.2.1 for clip locations.
- 3.2.11.4 Using a #2 Phillips screwdriver, remove the 16 sheet metal screws securing the keyboard to the bottom of its enclosure. The aft row of screws have flat washers under them. Take care not to drop any into the assembly and be certain to reinstall them when reassembling.
- 3.2.11.5 Carefully remove the keyboard from the unit while guiding the three ribbon cables/connectors through the foil slots. The keyboard can now undergo maintenance/repair.
- Note: the circuit boards can now be easily removed for replacement/service by removing the 16 Phillips head screws securing each of the two boards.
- 3.2.11.6 Keyboard reinstallation is accomplished by reversing steps 3.2.11.1 through 3.2.11.5 above.

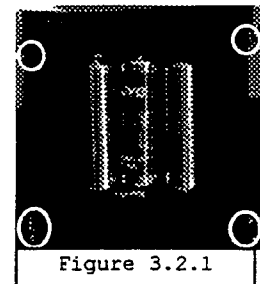

## Section 3

KURZASSM.DOC 12/22/92

- 3.2.12            KEY REPLACEMENT
- 3.2.12.1        Remove the keyboard as per section 3.2.11 above and lay the keyboard on a clean, soft surface to prevent damage.
- 3.2.12.2        Locate the defective key in need of replacement. Note: if it is a sharp (black) key, both the natural keys (white) on either side of it must be removed before it can be removed.
- 3.2.12.3        Remove the spring from the back of the key taking note of the positioning of the two ends. The wide end of the spring goes to the the top of the key. This can be easily removed with a pair of needle nose pliers by lifting one end of the spring out of its socket.
- 3.2.12.4        Insert a small/medium size flat blade screwdriver into the square opening in the top of the key near the rear. Gently turn this such that it releases the retaining clip while lifting the rear of the key. Then tilt the key toward the front of the keyboard and remove.
- 3.2.12.5        To install a key simply reverse 3.2.12.4 above. When inserting the rear of the key, firmly press it down with your fingers until it clicks, then install the spring (wide end up).



Section 3

NOTES

**3.3 K2000R DISASSEMBLY/ASSEMBLY INSTRUCTIONS**

NOTE: Under most conditions it will be necessary to disconnect all audio cables, MIDI cables and AC power cord from the unit to facilitate secure placement of the K2000R on a firm surface before removing the cover. It is your responsibility to ensure the safety of the unit.

**3.3.1 Cover Removal**

- Place the K2000R on a firm, flat surface.
- Using a #2 Phillips screwdriver, locate and remove the eight (8) machine screws securing the cover; four (4) on each side of the unit.
- Gently lift the cover from the unit.

**3.3.2 K2000R Connector Board Removal**

- Remove cover as per 3.3.1 above.
- Disconnect ribbon connectors J411 and J412 on the K2000R Connector Board.
- Locate and remove the two (2) hex head screws securing the connector labeled "SCSI THRU" (J412) to the rear panel.
- Remove the ten (10) nuts securing the 1/4" jacks to the rear panel.
- Lift out the K2000R Connector Board.
- Reverse this procedure for reinstallation.

**3.3.3 Engine Board Removal**

- Remove the cover as per 3.3.1 above.
- Remove the K2000R Connector Board as per 3.3.2 above.
- Remove all wiring connectors including ribbon cables.
- Locate and remove the two (2) hex head screws securing the DB-25 connector labeled "SCSI".
- Locate and remove the six (6) screws securing the three MIDI connectors using a #1 Phillips screwdriver.
- Locate and remove the six (6) screws mounting the Engine Board using a #2 Phillips screwdriver.
- Remove the Engine Board.

NOTE: It is NOT necessary to remove the Connector Board or the Engine Board in order to install SIMMs or to replace the system software.

- Reverse this procedure to install the Engine Board.

**3.3.4 Audio/Power Board Removal**

- Remove the cover, Connector Board, and Engine Board as per 3.3.1, 3.3.2, and 3.3.3 above.
- Remove any remaining connectors.
- Locate and remove all mounting screws using a #2 Phillips screwdriver.
- Reverse this procedure to install.

### **3.3.5 Front Panel and Display Access and Removal**

**NOTE: To access and/or remove the Front Panel or Display, the front panel escutcheon must first be removed.**

- Remove the securing nut to the 1/4" jack at the bottom of the escutcheon just to the right of the volume knob.
- Remove the six (6) flat head screw securing the escutcheon; two on top (one at each end) and four on the bottom.
- Gently remove the escutcheon.

#### **3.3.5.1 Display Removal**

- Using a #2 Phillips screwdriver, remove the four (4) screws mounting the Display to the frame.
- Trace the twisted pair of yellow wires to J2 on the Backlight Board (located in the top right hand corner of the unit just behind the front frame. Disconnect J2.
- Trace the ribbon cable to J4 on the Engine Board and disconnect. The Display can now be removed/repared/replaced.

#### **3.3.5.2 Front Panel Removal**

- Trace the ribbon cable to its connector on the left hand edge of the Audio/Power Board and disconnect.
- Using a #2 Phillips screwdriver, remove the thirteen (13) screws securing the Front Panel to the frame and remove the assembly.
- Reverse 3.3.5 above to install Front Panel and/or Display.

**3.3.6 Removal of any other items in the K2000R remain obvious and requires no discussion.**

## SECTION 4

### 4.0 MAINTENANCE, CARE AND PREVENTION, TROUBLESHOOTING

- 4.0.1 With a modicum of care, the K2000 will provide years of use and enjoyment. There are just a few important points to keep in mind.
- 4.0.2 Proper installation is essential to the health and welfare of the K2000. It should rest on a stable keyboard stand, or on a hard flat surface. If a flat surface is used, the K2000 MUST rest on its rubber feed, and NOT on the bottom panel. NEVER block the ventilation openings on the rear panel; doing so can cause overheating which may seriously damage the K2000! To provide adequate ventilation, the rear panel should be at least four inches from any vertical surface. If you install an internal hard disk, the ventilation opening on the underside of the K2000 must remain unobstructed so the cooling fan can operate properly. Care should be taken to minimize the amount of dust in the environment.
- 4.0.3 There are no user-serviceable parts in the K2000. Under no circumstances should anyone other than a qualified technician attempt to remove any panels from the unit, except for battery replacement. Any attempt to open the K2000 risks severe electrical shock and will void the product warranty.

### 4.1 CLEANING THE K2000

- 4.1.1 It is always a good idea to remove dust from the K2000 occasionally. Dust can be easily removed by using the brush attachment with a vacuum cleaner and gently working same into the gaps between the keys, buttons, etc. DO NOT REMOVE ANY PANELS! To remove routine fingerprints and smudges, use a soft damp cloth with a mild detergent (such as dish washing detergent). Never use strong cleaners or solvents, and never spray anything on the front panel or into the ventilation holes! Any cleaners you may want to use should be applied to your cleaning cloth; you can then carefully wipe the surfaces of the K2000.

### 4.2 FLOPPY DRIVE MAINTENANCE

- 4.2.1 Care should be always taken to keep dirt and dust out of the floppy disk drive, thus few (if any) problems will result. If, however, errors or failures in loading or saving are experienced, dust or dirt in the drive may be the cause. Consult your dealer or authorized service center for information regarding products and techniques for floppy drive cleaning. DO NOT ATTEMPT TO DISMANTLE THE UNIT OF THE FLOPPY DRIVE!

### 4.3 BATTERY SELECTION AND REPLACEMENT

- 4.3.1 The K2000 uses batteries to preserve its internal memory when the power is turned off. The original batteries should last at least one year before they need replacing. Replacement is necessary when the LCD says "BATTERY VOLTAGE IS LOW" during power-up, or when it is noticed the LEDs flash twice instead of once during power-up. Once these warnings begin to occur, the

**SECTION 4**

batteries should be replaced within a couple of weeks to ensure continued safety of your RAM entries.

4.3.2 To replace the batteries, turn the unit over on a soft surface and remove the battery compartment cover (see Figure 4.1). A small tool, such as a screwdriver, may be necessary in unlatching the tab. Be careful not to break this tab. Replace the batteries with three high quality AA size "heavy duty" or alkaline batteries. A capacitor will keep the memory alive for about 30 seconds while changing the batteries, thus do not remove the old ones until the new ones are ready for installation. Alternatively, it is permissible to the power cable plugged in and the power on while changing the batteries, in which case memory will be retained as long as power is on. Be sure to insert the new batteries in the directions indicated by markings in the bottom of the battery compartment. Incorrect insertion won't damage anything but the memory won't receive any power from the batteries.

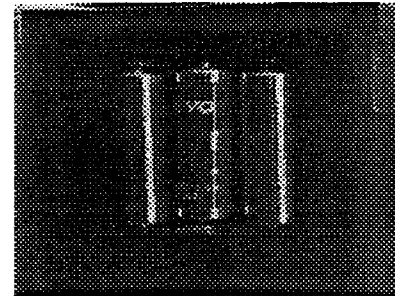

Figure 4.1 - Battery positioning

4.3.3 Most quality brand-name batteries now have "sell by" dates printed on their packages. Carbon-zinc batteries will last for at least a year after installation while alkaline batteries should last for at least 2 years provided they are installed before the date on the package. Rechargeable batteries should not be used; the K2000 will not recharge them and their life after charging on an external charger will be only a few months. Battery life is not significantly increased by leaving your K2000 on all the time; batteries may even suffer heat degradation if the K2000 is left on continuously.

**4.4 USER CALLABLE DIAGNOSTICS**

4.4.1 If difficulty is experienced with a third-party switch pedal or control pedal, the built-in user callable diagnostic program may help in diagnosing the problem. This program will display on the LCD exactly what the K2000's internal computer sees when the pedal is used. This can help determine if there really is a physical problem with the pedal or merely a programming problem in your program or setup. The diagnostic can be used to check out the keyboard and built-in controls as well.

4.4.2 To enter the diagnostic program, simply press the 4, 5, and 6 buttons simultaneously when in the Program Mode. The K2000 will respond by lighting each LED in sequence and then displaying the following on the LCD:

**K2061 SCANNER DIAGNOSTICS VERSION 1.4**

**(PRESS "EXIT" AND "ENTER" TO EXIT)**

**BATTERY=4.5 VOLTS, WHEEL CENTER=128**

**XXXXXXXXXXXXXXXXXXXXX**

SECTION 4

- 4.4.3 The battery voltage and wheel center values may be different on your unit. The fourth line (represented by XXXX) is the one of interest in diagnosing pedal problems (if it is flickering, move the right wheel toward the center of its rotation; if it is blank, all is OK).
- 4.4.4 To see how the display works, first plug the footswitch that came with your K2000 into the FOOTSWITCH 1 jack on the rear panel. When the footswitch pressed, the fourth line should read:
- PEDAL 1**
- 4.4.5 When the footswitch is released, the fourth line should become blank. When plugged into the FOOTSWITCH 2 jack, the action should be similar except that "PEDAL 2" will be displayed.
- 4.4.6 Now try your third-party footswitch. If it acts the same way as the Kurzweil unit, then all is well from a hardware standpoint. IF the fourth line remains blank when the footswitch is pressed, there is a problem with the footswitch; either its internal switch, the connecting cable, or the plug. Likewise if "PEDAL X" always shows whether the footswitch is pressed or not, there is a short circuit somewhere along the line. Some footswitches will act backward, that is, the display will show "PEDAL X" immediately when the footswitch is plugged in and will go blank when the footswitch is pressed. This type of footswitch can be used with the K2000, but it must be plugged in **before** the power is turned on. Alternatively, performing a "soft-reset" (press "+ -", "0", "CLR" together) after plugging in a backward footswitch will result in proper operation.
- 4.4.7 The diagnostic program may be used to examine the action of a control pedal as well. To get an idea of how this works, move the CONTROLLER slider on the K2000 panel up and down and look at the fourth line. It should say "DATA SLIDER = XXX" where XXX varies from 0 or 1 (slider down) to 254 or 255 (slider up). Move the slider very slowly; the numbers will tend to increase or decrease by twos. This is part of the "anti-flicker" routine used by the diagnostics, and is normal.
- 4.4.8 Now try the control pedal. When connected, the fourth line will change to show "CONTROL PEDAL - XXX". Rocking the pedal forward should make the numbers increase toward 255 while retiring it should make them decrease. Moving the pedal to approximately mid-position should yield a reading of around 130 (100 - 160 is typical). Common control pedal problems are backward action (rocking forward makes the numbers decrease), restricted range (the numbers will not reach 254 or 255 in the forward position or 0 or 1 in the back position), and non-linearity (rocking halfway forward gives a reading substantially less than 100).
- 4.4.9 For any of these problems, first check the connection pattern between the potentiometer in the pedal and the stereo plug. The wiper must be connected to the tip, the lower end of the potentiometer (the end the wiper moves toward when the pedal is retired) connected to the sleeve, and the upper end to the ring. If a volume pedal is being used and it will not go to zero,

**SECTION 4**

there is often an adjustment on the pedal that might correct that. The only solution for a highly nonlinear pedal is replacement of the potentiometer (which probably has a so-called "audio taper") with one that has between 10K and 100K of resistance and a "linear taper".

- 4.4.10 As seen, the diagnostic program can also be used to check out the built-in panel and performance controls of the K2000. Like the Controller Slider, moving either wheel or pressing on the keyboard will show a controller name and reading between 0 and 255. If you move the Alpha Wheel clockwise, the numbers will go 0-1-2-3-0-1-2...while counterclockwise should produce 3-2-1-0-3-2... If you press a button, its name will be shown and if it is one of the mode buttons, its associated LED should flash.
- 4.4.11 The third line of the display shows the results of two measurements that are made whenever your K2000 is turned on. The battery voltage will be about 4.5 volts for new batteries gradually declining over time to 3.2 volts, at which point you will begin to receive warnings (see "BATTERY SELECTION AND REPLACEMENT" above). The wheel referred to is the spring-centering software will work perfectly. If it is outside that range, the wheel will still be automatically centered but you may not get the full control range in one direction. Please see your Kurzweil/Young Chang dealer for any needed wheel adjustments.

#### **4.5 MAXIMIZING MUSIC AND MINIMIZING NOISE**

- 4.5.1 The K2000 quite possibly has the lowest noise and widest dynamic range of any instrument in the industry. The following tips will enable you to make the most of this, and optimize the K2000's audio interface to your other equipment.
- 4.5.2 Setting your audio levels appropriately is the key to optimizing the signal-to-noise ratio of any piece of equipment. you may have noticed that the K2000's output signal seems less "hot" than most other synths when using the unedited factory sounds. This is to allow virtually any configuration of voice assignment to be used (up to 96 oscillators directed to one output!), and played very loudly with almost no chance of overload distortion. For more controlled adjustments, it is best to increase the output level digitally (by editing programs) instead of increasing the gain of your amplifier or mixing board. This is because a digital gain increase is completely noiseless whereas an analog increase will proportionally increase hum and noise from the connecting cabling and from the K2000 itself.
- 4.5.3 Increasing the volume digitally can be accomplished in three ways. You can increase the volume of all programs assigned to a given MIDI channel by selecting the CHANLS page in MIDI mode and setting the OutGain parameter to the desired level (in 6dB steps). For multi-timbral sequences (on multiple MIDI channels), you will need to do this for each channel. Alternatively you can increase the volume of a single program by going to the OUTPUT page in the Program Editor and setting the Gain parameter to the desired level, again in 6dB steps. For finer adjustment, the Adjust parameter on the F4 AMP page can be used.

## SECTION 4

- 4.5.4 Increasing the level too much can cause clipping distortion when multiple notes are struck loudly. For dense sequences all played through the same outputs, you will probably only be able to increase the volume by 6dB or so without risk of distortion. For monophonic instruments (lead guitar) or single instrument tracks (such as drums), a substantially greater boost is generally possible.
- 4.5.5 For the absolute maximum signal quality, the individual outputs should be used. These are connected almost directly to the 18-bit digital-to-analog converters with a minimum of noise-inducing processing circuitry. A total dynamic range of over 100dB is available at these outputs. The MIX outputs are naturally somewhat noisier because they represent the noise of the individual outputs all mixed together, and the signal must travel through more circuitry to reach them.
- 4.5.6 Programs which are routed through the K2000's global effects processor (Output Group A) will also be slightly noisier than programs routed to Output Group B. As with an external effects unit, maximizing the input signal level (using the methods described above) will improve the signal-to-noise ratio of the effects processor. When in Effects mode, you will see an internal Wet/Dry mix parameter; in the Effects Editor you will find numerous parameters for setting the level of the various effects. Your best signal-to-noise ratio will be achieved by setting the effects level parameters to maximum and adjusting the Wet/Dry Mix parameter to set the overall effects mix. If you are only using the effects unit for EQ functions, one of the EQ or Tone Control functions accessible through the program Editor will produce quieter results than the global effects processor's EQ functions (Parametric EQ, Para Bass, Para Mid, or Para Treble, for example).
- 4.6 **GROUND HUM**
- 4.6.1 A common problem with all electronic musical gear is the hum that can occur in connection cables due to AC ground loops. Although "3-prong to 2-prong" AC adapters are frequently used break ground loops, they also break the safety ground that protects you from electric shock. Using these adapters is dangerous and SHOULD NOT be done! Furthermore, although using these adapters may reduce low-frequency hum, high-frequency line noise (such as motor switching noise) is likely to get worse in this case, since the K2000's AC noise filter will have no outlet for the noise it filters if you disable the ground.
- 4.6.2 To reduce ground hum, you can increase your output signal levels as described earlier in this section. Other safe procedures include plugging your mixing board and amplifier into the same outlet as your K2000, and making sure that all your gear is properly grounded. If your're using an external SCSI device, plug it into the same outlet as well. AC isolation transformers are extremely effective at eliminating ground loops, and are recommended for critical installations. A 75 watt transformer is sufficient for the K2000.



## SECTION 4

- 4.6.3 For studio applications, where the utmost signal purity is required, using audio unbalanced-to-balanced line transformers will give you the best results. Each of the K2000's audio outputs can easily drive a 600 ohm transformer.
- 4.6.4 Finally, magnetic fields can be a source of interference. The area surrounding the K2000's Alpha Wheel and alphanumeric pad is sensitive to fields from large transformers in power amps; keep them at least a foot away from the K2000's front panel. Smaller gear like drum machines and hardware sequencer can also cause interference.
- 4.7 **POWER PROBLEMS AND SOLUTIONS**
- 4.7.1 The K2000 is quite tolerant of voltage fluctuations, noise, and transients in the AC power it receives. The input line filter and grounded power cable will protect against even large amounts of noise from motors and the like while the built-in filter coupled with the fuse will protect against all but the largest transients. If your installation is actually suffering from line noise or transients, most likely your other equipment will be suffering more than the K2000.
- 4.7.2 Very low line voltage or severe voltage dips are a problem for any computer-based instrument. When the K2000 is set for 120 volt input (the normal North American setting), it should function down to 90 volts. If the line voltage drops below 90 volts, a special circuit halts all activity to protect against software crashes or damage. When the line voltage returns to and stays at an acceptable level for at least one second, the computer will automatically restart. The net effect is just as if you had performed a soft reset. Continuous low line voltage or transient dips will never produce symptoms other than unexpected soft resets as just described. Any other problems such as distortion, disk errors, or lost data are cause by something other than line voltage fluctuations.
- 4.7.3 Soft resets from line voltage dips are most common. These are easily identified because the reset occurs coincident with the building lights dimming, stage lights or power amps being switched on, or air-conditioning equipment starting up. The solution in all cases is to get a more direct connection between your K2000 (and any other computer-based equipment) and the building's power. Floodlights, large power amplifiers, and motor-operated devices should use a separate extension cord; preferably they should be plugged into a separate outlet.
- 4.7.4 Chronic low line voltage is best confirmed by measurement. Readings below 100-105 volts mean that even small dips could cause resets, while readings below 95 volts (accounting for meter inaccuracies) are a definite problem. Again, the best solution is to separate your heavy lighting and amplifier loads from your K2000 and other synths on separate extension cords or separate circuits when possible. If the actual building voltage is that low, use of an external step-up transformer or voltage regulator is recommended. we DO NOT recommend changing the line voltage to 100 volts (220 volts in Europe) because overheating or blown fuses may occur if you leave the K2000 at the lower setting and use it later at a normal voltage level.

**4.8 TROUBLESHOOTING**

- 4.8.1 Everything possible has been done to ensure the K2000/K2000R is delivered free of defects. There is a good chance there is nothing wrong with the unit, even if you are not seeing the proper display or hearing any sounds. If so, carefully check the following items:
1. Make certain the power input receptacle is set to the correct voltage, and is functioning properly.
  2. Ensure the power cable is connected to a reliable power source.
  3. Adjust the display contrast if necessary (with the Contrast parameter in Master mode). If for some reason you have trouble reading the display, even after adjusting the Contrast parameter, you can also adjust the contrast by holding down the ENTER button and turning the Alpha Wheel. IF this improves the contrast, immediately return tho the Contrast parameter and adjust it slightly. This will cause the K2000/K2000R to remember the current display contrast level, and should take care of any difficulties you may have been having. If this procedure doesn't work, the service technician should contact the Kurzweil Service Department.
  4. Check that the Volume slider is at least partially up from it's bottom position.
  5. Reaffirm that the proper audio cables are fully connected to the K2000/K2000R and to a sound system; also making certain the sound system is properly connected to power and turned on. If sound is still not heard, a good suggestion would be to test the audio cables, replace them, or test for sound by connecting a high quality pair of headphones to the headphone jack.
  6. Check the volume of your sound system.
  7. Lower the volume of the sound system, turn the K2000/K2000R off, then on again. This is called a power cycle.
  8. Press the +/-, 0, and CLR (on the numeric pad to the right of the front panel) simultaneously. This is called a soft reset.
  9. As a last resort, save to disk any RAM objects you've created, and perform a hard reset as per paragraph 4.12.1 (page 11) for early software versions or paragraph 4.19.1 (page 29) for software versions V1.30 and above. The K2000/K21000R will warn you about deleting everything (only RAM objects will be deleted). Press "Yes". After a few seconds, the power-up display should appear.
- 4.8.2 For additional assistance, check the items in the following troubleshooting guide.

**SECTION 4**

**4.9 OTHER POSSIBLE PROBLEMS**

<b>CONDITION</b>	<b>POSSIBLE CAUSE</b>
No sound, no display, no LEDs illuminated.	<ol style="list-style-type: none"><li>1. AC line cord not fully inserted into outlet or unit. If using a multiple outlet box, check its plug.</li><li>2. Power not on at AC power source (wall outlet). Check with a different appliance.</li><li>3. Power switch not on (either the unit or multiple outlet box).</li><li>4. Incorrect voltage selection setting. REFER TO SECTION 2 FOR DETAILS IN CHANGING SELECTION.</li><li>5. Open primary fuse in AC power connector.</li><li>6. Defective power switch, AC power connector, power transformer in K2000.</li></ol>
No sound.	<ol style="list-style-type: none"><li>1. Volume control turned all the way down on the K2000 or on amplifier or mixer.</li><li>2. Amplifier or mixer not turned on.</li><li>3. Incorrect audio cabling - REFER TO SECTION 2 FOR DETAILS. Also check to see if amplifier, mixer, or speaker wiring is correct.</li><li>4. MIDI volume has been assigned to a controller other than the volume slider, and that controller has been set to zero.</li></ol>

SECTION 4

4.9 OTHER POSSIBLE PROBLEMS

CONDITION	POSSIBLE CAUSE
No sound at MIX outputs or headphones.	1. Audio cables are plugged into the "A" or "B" outputs. Cables plugged into some or all of the separate outputs remove the audio signal from the MIX and headphone outputs. See Chapter 18 - "Audio Outputs" of the Musician's Guide for detailed configurations.
Left MIX output seems louder than Right MIX output when used individually.	1. This is normal. When a cable is plugged into the left MIX output alone, both the left AND the right audio signals are routed to the jack. When a cable is plugged into right MIX output alone, only the right channel audio signal is heard.
Volume slider has no effect.	1. Separate outputs are in use - the volume slider does not affect the "A" or "B" outputs. 2. MIDI volume has been assigned to a different controller.
Programs, Setups, Songs, etc. are missing.	1. Batteries have run down or have been disconnected. If the batteries have failed, the message "Battery voltage is low - 0.0 volts" will appear in the display on power-up. All user data will be permanently lost if this occurs. REFER TO SECTION <u>        </u> FOR DETAILS ON BATTERY REPLACEMENT.

SECTION 4

4.9 OTHER POSSIBLE PROBLEMS

CONDITION	POSSIBLE CAUSE
LCD is too dark or too light to read.	1. Contrast not adjusted. Select Master mode and adjust the Contrast parameter. If this fails, hold the ENTER button and turn the Alpha Wheel clockwise to make display darker; counterclockwise to make it lighter. Then adjust the Master mode Contrast parameter to a higher value if the LCD was too light, or to a lower value if it was too dark.
Cannot mount or read disk.	1. Disk is not MS-DOS (or Akai) format. 2. Disk is damaged.
Cannot write floppy disk.	1. Disk is not MS-DOS formatted. 2. Disk write protected. 3. Sample is copy protected. 4. Disk is damaged.
Cannot format disk.	1. Disk is damaged. 2. Disk is write protected.

**4.10 K2000 DIAGNOSTICS VERSION 0.4****(K2000 WITH VERSION 1.0 ENGINE SOFTWARE)**

This document is intended only for qualified Kurzweil service technicians. It will explain how to use the K2000's internal diagnostic software, describing the significance of success or failure of each of the individual tests, and when applicable, the measures required to correct test failures will be given.

This document is for use with K2000 Diagnostic software Version 0.4. Version 0.4 of the diagnostic software is included with K2000 Version 1.0 Engine software. Version 1.2x of the K2000 Engine software include Version 1.0 of the diagnostic software, which differs slightly from Version 0.4. If the unit you're working on has Engine software Version 1.2x, please refer to the K2000 Diagnostics document for Version 1.0 of the diagnostic software.

**4.11 INTRODUCTION**

This introduction will explain the general structure of the diagnostic software, and the types of tests that can be performed.

**4.11.1 Diagnostic Software Structure**

When you enter the K2000's diagnostic mode, you will see a menu of available tests. At this point you can choose to run the standard Burn-in test, or you can select individual tests to diagnose specific components. The Burn-in test automatically initiates a series of tests to check the basic functionality of the K2000's hardware.

There are three general types of tests: memory RAM, ROM, and I/O (input/output). The descriptions of each diagnostic test will identify their general types.

**4.12 USING THE K2000 DIAGNOSTIC SOFTWARE****4.12.1 Entering Diagnostic Mode**

**IMPORTANT NOTE:** Before you begin the diagnostics, be sure that the owner of the K2000 has backed up any data stored in RAM, since the diagnostics will completely clear the unit's RAM. Refer to section 13 of the Musician's Guide for details on backing up RAM.

First, remove the battery access panel on the bottom of the unit and disconnect the batteries. Wait 5 minutes for the battery capacitors to discharge, then turn the unit over, plug it in, and turn it on. You'll see a display presenting three options: Hard Reset, Cancel, and Diagnostics. See Figure 4.2. Use the Alpha Wheel to select the desired option, highlighting it in reverse. Then press the ENTER button to execute your choice. Selecting DIAGNOSTICS will enter the K2000's diagnostic mode. Selecting HARD RESET will reset the K2000 (hard reset) and return it to Program mode. Selecting CANCEL will also execute a hard reset and return to Program mode.

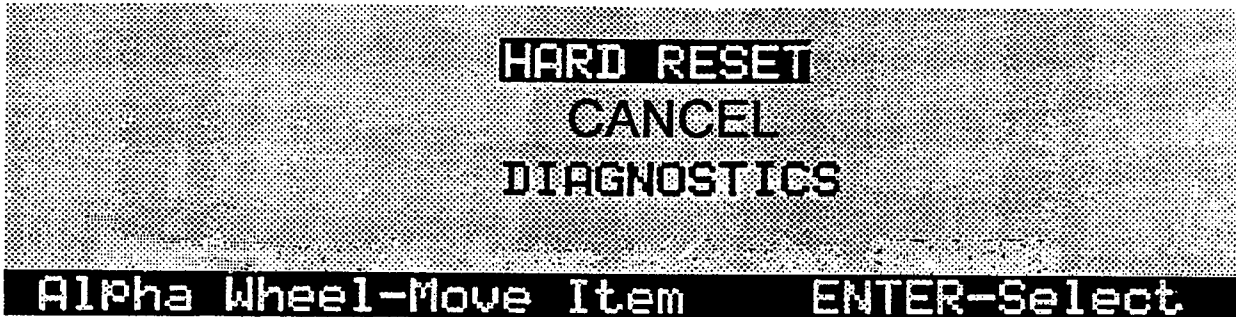

Figure 4.1 - Special K2000 Power-up Options

Upon entering diagnostic mode, a menu of available tests appears. See Figure 4.3. The soft buttons are labeled by the bottom line of the display. The options are "A Burn-in Test", or "B Test Forever."

NOTE: The option labeled "Burning Test" on the bottom line of the display refers to the Burn-in test, so called because it's used at the factory to perform a general quality test of all the major components of the unit. These tests are done multiple times to make sure the unit will perform properly with extended use.

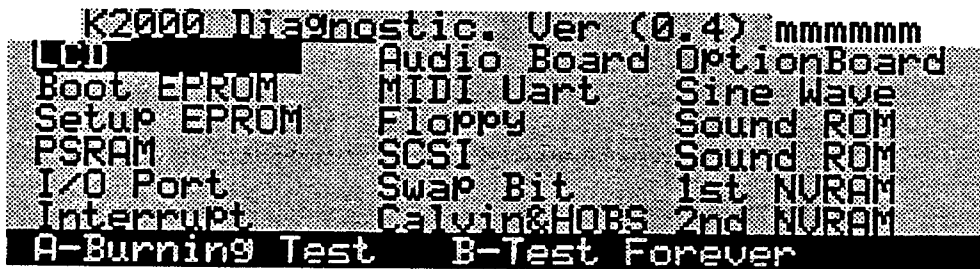

Figure 4.3 - Diagnostic Test Menu

Performing the Burn-in test on newly shipped units is recommended for a general test. If a specific problem has occurred with a particular unit, select the appropriate test(s) from the normal diagnostics menu. If repairs or replacement of parts are necessary, to run the Burn-in test one or more times when you've finished the repairs.

#### 4.12.2 Running the Burn-in Test

NOTE: Before running the Burn-in test, insert a formatted floppy disk into the K2000's floppy disk drive. The test will hang up without a disk in the drive.

When the diagnostic test menu is displayed, press the A soft button (the farthest to the left) at any time to begin the Burn-in test sequence. When the Burn-in test is selected, the display changes to show the list of tests included in the Burn-in sequence. As each test is completed, the display is updated to show the result. See Figure 4.4. The Burn-in test is adequate for testing the unit's major components; if all the Burn-in tests pass, the unit should be in full working order.

NOTE: An SCSI device must be connected to the unit's SCSI port, otherwise the SCSI test will fail. This does not necessarily indicate a malfunction of the SCSI link.

```

LCD          :
Boot ROM    :
Setup ROM   :
PSRAM       :
I/O port    :
Interrupt   :
AudioBoard  :
Floppy      :
SCSI        :
Sound ROM   :
Sound RAM   :
Exit-Break Total-0000 Fail-0000

```

Figure 4.4. Burn-in Test Menu

The Burn-in test can be aborted at any time by pressing the EXIT button, then pressing any button on the front panel to return to the diagnostic test menu (the display says "Press any key," meaning a front panel button, not one of the black-and-white keys). It may be necessary to press the EXIT button more than once, because the K2000 can only recognize switch closures between tests.

Press any front panel button to interrupt the Burn-in test temporarily. The test will resume when the button is released. Press any one of the keys, the test will be interrupted and hold temporarily; it will resume when any front panel button is pressed.

#### 4.12.3 Selecting a Specific Test

To run an individual test, use the Alpha Wheel to select the desired test from the diagnostic test menu. The selected test is highlighted in reverse. Press the ENTER button to run the selected test one time. When the test is completed, the display will show the result of the test. Normally each test need only be run once in the attempt to identify failures. Running a given test continuously is recommended to monitor the K2000's output signal with an oscilloscope, since many tests are completed too quickly to be monitored in a single pass.

#### 4.12.4 Continuous Testing

A selected test can be run indefinitely by pressing the B soft button (second from the left). This will cause the selected test to run until it is interrupted with the EXIT button. Remember, it may be necessary to press the EXIT button more than once.

Press any front panel button to interrupt a continuous test temporarily. The test will resume when the button is released. Press one of the keys, the test



will be interrupted and hold temporarily and will resume when any front panel button is pressed.

As the continuous tests are running, the bottom line of the display will indicate the number of tests that have been completed, and the number of failures that have occurred.

**4.13 TEST TYPES**

The tests described in this section are of three types, referred to as RAM tests, ROM tests, and I/O tests. Memory tests check the physical memory addresses of the data corresponding to various components. This is done by writing an arbitrary test data pattern to memory and reading it back, comparing the written data to the read data. ROM tests involve comparing the data stored in the ROM components to a checksum. I/O tests also send a test data pattern from the central processor to the component(s) being tested, and check whether the data are being exchanged properly between the central processor and the tested component(s).

**4.13.1 Memory tests**

There are two stages to a memory test: the data test, and the address test. In the data test, a test data pattern is written from the processor to the memory component being tested. The diagnostic software expects the data pattern that's written to memory to be read back exactly as it was written. If this is the case, the test passes. If the observed data (the data read from memory) differ from the expected data (the data written to memory), the test fails.

When a data failure occurs, it is displayed in the following format: the memory address where the failure occurred; the expected hex value at that address; the actual observed value at that address. See Figure 4.5 for an example.



**Figure 4.5. Data Failure**

In the address test, the central processor (CPU—a Motorola 68301) checks every memory address related to the component being tested. A test data pattern is written to each address, and then read back. The diagnostic software expects the data pattern to be read back from the same address to which it was sent. If the observed address (the address read from) matches the expected address (the address written to), the test passes. If the observed address does not match the expected address, the test fails. Address failures are displayed

in the following format: the expected address; the observed address. See Figure 4.6 for an example.

NOTE: Many figures in this document show values of all zeros. You'll see non-zero values for the address, expected values, and observed values of all tests. The expected and observed values themselves are not significant; what's important is that a difference between the expected and observed values indicates a test failure.

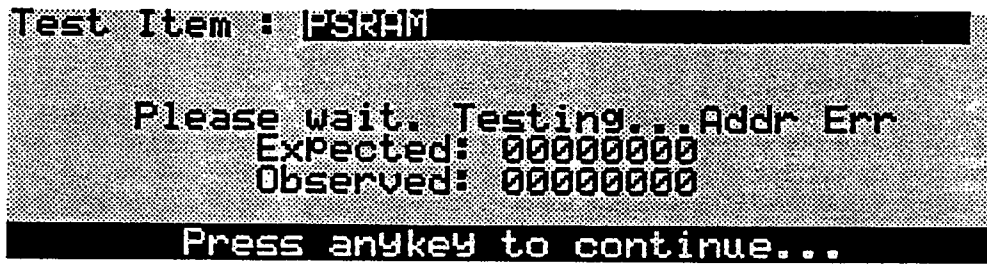

Figure 4.6. Address Failure

#### 4.13.2 ROM Tests

Since data cannot be written to ROM components, tests are done by reading the data from the ROM components and summing the hexadecimal values of the data. This sum is compared to a checksum stored in the last two memory addresses of each component. The two sums must match for the test to pass.

#### 4.13.3 I/O Tests

In an I/O test, a test data pattern is sent from the CPU to the component being tested. The signal is processed by the component, and returned to the central processor. If the signal returns to the central processor as expected, the test is a success. If the observed pattern differs from the expected pattern, the test fails.

Each of the tests described below will be either a memory test or an I/O test (or, in some cases, a combination of the two). When performing single passes of specific tests, the display will indicate the result of the test upon its completion. In most cases, the result will be Success (Pass), Data Fail, or Address Fail. Unless otherwise specified, failures will be displayed as described in the previous paragraphs.

### 4.14 DESCRIPTIONS OF TESTS

#### 4.14.1 LCD Test

This test has both an I/O stage and a memory stage. It checks the connections between the LCD and the engine board, as well as the memory of the LCD itself.

The processor writes a test data pattern to the LCD memory, then reads it back expecting a certain value. If the observed value does not match the expected

value, a data failure is indicated. This could indicate a processor error, a faulty LCD, or a faulty connection from the LCD to the engine board.

#### **4.14.2 Boot EPROM Test**

This memory test checks the integrity of the Engine software data stored in the ROM chips located on the engine board at U3 and U6. It reads the data from each address and compares it to a checksum stored in the ROM chips. It also checks for errors in the pin connections of each of these chips. If all checksums match, the test is a success. If there are checksums that do not match, the display will show either "Even Fail" or "Odd Fail." If you see an Even Fail message, remove the chip located at U3 and test it in an EPROM programmer. If the checksums match, the chip is good, and a connection problem at U3 is indicated. If the checksums do not match, the chip is improperly programmed and should be either reprogrammed or replaced. Likewise, if you see an Odd Fail message, remove and test the chip from location U6.

NOTE: The sockets at U3 and U6 are labeled "SETUP" on the engine board. Even so, the chips installed in these sockets are the Engine software EPROMs. This discrepancy is due to a design change that was made after the engine board was finalized and printed. For Engine software Version 1.0, the SETUP sockets contain the Engine software, and locations U2 and U5 are unused. Nevertheless, the Boot EPROM test checks the Engine software EPROMs.

#### **4.14.3 Setup EPROM Test**

Similar to the Boot EPROM test, this is intended to check the data and pin connections of the ROM chips located at U2 and U5 on the engine board. For Engine software Version 1.0, these locations are unused, and the test will fail. This does not indicate a malfunction.

#### **4.14.4 PSRAM Test**

This is a memory test of the pseudo-static RAM chips located at U07 and U08 on the engine board. The results will be either Success, Data Failure, or Address Failure. If this test fails, the RAM chips should be replaced.

#### **4.14.5 I/O Port Test**

In this test, the integrity of data transfer within the CPU (location U9) is tested. This is done by writing a test data pattern from the low bit addresses of the CPU to the high bit addresses. The high bits then read the pattern and compare it to the original. If the patterns match, the test is a success. If the test fails, the CPU may be bad, but it is more likely that there is a problem with the I/O bus.

#### **4.14.6 Interrupt Test**

Also an I/O test, the Interrupt Test checks the connection between the IRQ0 (interrupt request) pin and the floppy disk controller in the CPU. A successful Interrupt test indicates that interrupt requests from the floppy disk controller are being received by the CPU's IRQ0 pin. Failure of this test indicates a defective connection between the CPU's IRQ0 pin and floppy disk controller, and could identify the cause of malfunctions in the floppy disk drive.

**4.14.7 Audio Board Test**

Another I/O test, this checks the connections between the engine and audio boards. When you run this test, the LCD will always display "Success," but this should be ignored, since it doesn't indicate the success or failure of the test. In a successful test, the eight LEDs to the left of the LCD will flash in sequence (from top left to bottom left to top right to bottom right) at 300 ms intervals. A failure of any of the LEDs to light indicates a defective LED or a faulty connection between the engine and audio boards.

**4.14.8 MIDI UART Test**

This I/O test checks the operation of the MIDI In and Out ports. Before executing this test, connect a MIDI cable from the K2000's MIDI Out port to its MIDI In port. A failure of this test is indicated in the display as a data failure as described in the overview. If this test fails, repeat the test with a different cable. If it still fails, this indicates that one or more pins in the MIDI Out and/or MIDI In port is defective.

**4.14.9 FDC Test**

**A blank formatted floppy disk (DOS 1.4M) must be inserted in the floppy disk drive before initiating this test. The test cannot proceed without a disk inserted in the drive.**

The FDC (floppy disk controller) test is an I/O test, and checks the functionality of the NEC PD72064 chip, the floppy disk drive, and their connections. The test entails sending a test data pattern from the floppy disk controller (FDC) to the floppy disk drive (FDD) and back. If the display indicates a successful test, then the connections between the FDC and FDD are functioning, and the test data pattern written by the FDC and read from the FDD are identical. If the display indicates "Read Fail," there is a problem in the connection from the FDC to the FDD. If it indicates "Write Fail," there is a problem in the connection from the FDD to the FDC. If the display indicates "Data Fail," the read and write operations are normal, but the "read" signal and the "write" signal do not match. In this case, the display will indicate a data failure as described in the overview.

**4.14.10 SCSI Test**

This I/O test is similar to the FDC test, and checks the functionality of the SCSI port. If no SCSI device is connected to the unit's SCSI port, this test will fail. This does not necessarily indicate a malfunction of the SCSI link. To be sure that the SCSI link is operational, you should connect a SCSI device before running this test.

**4.14.11 Swap Bit Test**

The 68301 processor's 16 megabits of address space are divided into 16 equal memory blocks, numbered 0-15. The first time the K2000 is powered up, Block 0 processes data for the Boot EPROM and Setup EPROM, while Block 1 processes data for the PSRAM. Many of the K2000's basic functions utilize the PSRAM, which accesses the higher address space of Block 1 in the CPU. This slows down the access time somewhat, since the address space of the CPU is accessed in sequence, beginning with Block 0.

To optimize the processing speed, the K2000 performs a one-time software operation when powered up for the first time. The memory management unit (MMU) in the gate array logic chip (GAL) located at U35 on the engine board executes a "swap bit" function which makes Block 0 of the CPU responsible for the PSRAM, and Block 1 responsible for the Boot EPROM and Setup EPROM. Consequently the PSRAM functions are processed as early as possible.

The Swap Bit Test checks to make sure that the swap bit function has taken place. The swap bit function also involves the GALs at U10 and U11. If the test fails, check the traces between U10, U11, and U35. If they appear intact, one or more of the GALs may be defective.

#### 4.14.12 Calvin and Hobbes Tests

**IMPORTANT:** The Calvin and Hobbes tests—especially tests 6 and 9—are not 100% reliable in Version 0.4. A Failure of any test may not necessarily indicate a component failure. If a failure message occurs, run the Calvin and Hobbes tests three or four more times, and compare the results. If any of the subsequent tests pass, the component in question is probably good. If the tests fail repeatedly, the component in question is probably—but not necessarily—bad. If failures occur with any of the Calvin and Hobbes tests, it is recommended the unit be upgraded to Version 1.2 Engine software, which includes Version 1.0 of the diagnostic software. The Calvin and Hobbes tests in Version 1.0 are reliable.

The 13-step Calvin and Hobbes memory test checks the connections between the CPU and the three VLSI sound engine chips: Calvin, Hobbes 0, and Hobbes 1. Calvin handles sample fetching tasks, and Hobbes 0 and 1 primarily perform wave form generation and DSP functions.

Calvin and Hobbes have undergone rigorous testing prior to mass manufacturing, and are extremely unlikely to be defective. If one or more of the steps in this test indicate a failure, the problem is probably to be found in the connections between the chips and the CPU. The test results are displayed as shown in Figure 6. The significance of failures in each step of the test is explained below. Steps 2.1–2.3 test the connections to the internal RAM and internal registers of Calvin and Hobbes.

When analyzing the results of these tests, the result should be a PASS message for each test. The hexadecimal numbers that appear on the display are irrelevant as long as they match for each test. The numbers shown in figure 5.6 are arbitrary, and may differ from the numbers seen in the unit under test. This does not indicate a problem.

If any of the tests fail, check the connections between the components in question, as described in the paragraphs below. If test #2 fails, check all the connections between the CPU, Calvin, Hobbes 0, and Hobbes 1. Note that expected values are not given on the line indicating the status of test #2. Instead, a PASS or FAIL message will be seen for each of the three steps in test #2.

**NOTE:** The Calvin and Hobbes tests are interrelated, and are sequenced from the least significant test to the most significant. If any one test fails, the subsequent tests are likely to fail as well. In this case, start by checking the components related to the first test that failed. If a malfunction occurs, repair the malfunction and run the Calvin and Hobbes test again. It is likely this will result in the subsequent tests will passing when retested.

## SECTION 4

In general, the data flow through these components is the following sequence: Sample memory, Calvin, Hobbes 0, Hobbes 1. If test failures occur, check the connections to Calvin before checking those to Hobbes 0, and Hobbes 0 before Hobbes 1.

No	Res	Exp	Obs	No	Res	Exp	Obs
1	PASS			7	PASS	AB53	AB53
2	PASS	PASS	PASS	8	PASS	09FB	09FB
3	PASS	3300	3300	9	PASS	852C	852C
4	PASS	0D80	0D80	A	PASS	3049	3049
5	PASS	0D80	0D80	B	PASS	6789	6789
6	PASS	0A04	0A04				

Press anykey to continue...

Figure 4.7. Calvin and Hobbes Test

- 1 **Checksum is different in Calvin CROM**  
Connection problem between CPU and Calvin
- 2.1 **Calvin Memory Test Fail**  
Connection problem between CPU and Calvin
- 2.2 **Hobbes 0 Memory Test Fail**  
Connection problem between CPU and Hobbes 0
- 2.3 **Hobbes 1 Memory Test Fail**  
Connection problem between CPU and Hobbes 1
- 3 **Calvin Sample Memory Checksum Test Fail**  
Connection problem between Calvin and sample memory
- 4 **Hobbes 0 Input Unit Holder Register Checksum Test Fail**  
Connection problem between Calvin and Hobbes 0
- 5 **Hobbes 1 Input Unit Holder Register Checksum Test Fail**  
Connection problem between Calvin and Hobbes 1
- 6 **Calvin Memory Checksum Test Fail**  
Connection problem between Calvin and CPU, or between Calvin and Sample memory
- 7 **Hobbes 0 Memory Checksum Test Fail**  
Connection problem between Calvin and Hobbes 0
- 8 **Hobbes 1 Memory Checksum Test Fail**  
Connection problem between Hobbes 0 and Hobbes 1

**9 Calvin Read Only Checksum Test Fail**

Connection problem between Calvin and Hobbes 0

**A Hobbes 0 Read Only Test Fail**

Connection problem between Calvin and Hobbes 0

**B Hobbes 1 Read Only Test Fail**

Connection problem between Hobbes 0 and Hobbes 1

**4.14.13 Option Board Test**

As of this writing, the K2000 sampling option has not been released, so there is no need to run this test. In fact, this test is extraneous, since installation of the sampling option will include Version 2.0 K2000 Engine software, which will include Version 1.0 of the diagnostic software.

**4.14.14 Sine Wave Test**

Executing this test enables generation of sine waves at the following frequencies: 20 Hz, 315 Hz, 630 Hz, 945 Hz, 1260 Hz, 2 KHz, 4 KHz, and 8 KHz. The sine wave at 20 Hz is generated as soon as the test is initiated. Pressing any button on the front panel (or turning the Alpha Wheel one click) will generate the next-highest test frequency. The unit will return to the diagnostic test menu when the sine wave is at 8 KHz and any front panel button is pressed or the Alpha Wheel is clicked to the right.

This test is intended for use with an oscilloscope connected to the K2000's audio output, and enables analysis of the purity of the sine wave generated. If the sine wave is impure, a problem with the sound engine is suggested. To monitor the Sine wave test, connect the scope to any of the B outputs, the MIX outputs, or the Headphone jack.

**4.14.15 Sound ROM Test**

This memory test takes about five seconds to run, and checks the data integrity of the K2000's sound ROM (the factory sounds), and the connections between the sound ROM and the CPU. The test is a simple checksum procedure for each pair of Sound ROM chips. Failures are indicated as data or address failures, as described in the overview. The display indicates the success or failure of each of the four blocks of Sound ROM (A-D). Each block corresponds to two Sound ROM chips. In the unlikely event of a failure, the engine board must be replaced, since the Sound ROM chips are soldered in place.

**4.14.16 Sound RAM Test**

This memory test checks the address space of the sample RAM (SIMMs). The purpose of this test is to determine whether the K2000 recognizes all of the sample RAM that has been installed. The more RAM that has been installed, the longer this test takes. The test takes approximately 80 seconds for each RAM block containing a SIMM, regardless of the SIMM's size.

NOTE: for Version 0.4 of the diagnostic software, this test is significant only if the unit contains SIMMs of 4 megabytes or smaller. If the unit contains larger SIMMs, the test will indicate success even if the SIMMs are

not functioning properly. To test SIMMs larger than 4 megabytes, Version 1.0 of the diagnostic software is required.

The K2000's sample RAM space is divided into two banks (Bank 0 and Bank 1), representing the two pairs of SIMM sockets. Each bank is divided arbitrarily into four blocks with a maximum address space of 8Mb. These blocks, A-D, represent internal divisions of the address space; they don't correspond to any physical division of the sample RAM.

When the Sound RAM test is run, the display will indicate which block in which bank is currently being tested. This is shown by a series of dots that appear as the test proceeds. As each block is finished, the dots are replaced with either a success message or a failure message; see Figure 4.8. If the block fails, the malfunctioning address is indicated, as well as the expected checksum value and the observed value. See Figure 4.9.

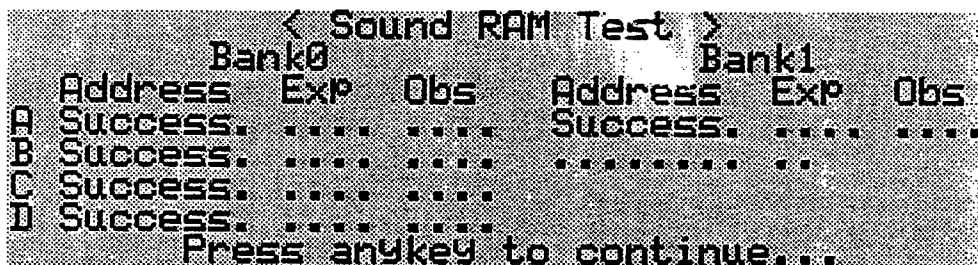

Figure 4.8. Sound RAM Test (currently checking Bank 1, Block B)

If any of the SIMMs is defective, or installed improperly, the display will indicate a data failure or address failure as described in the overview. A failure may also indicate a faulty connection between the Sound RAM and the engine board. See Figure 4.9 for an example of a failure message. In this example, Block B of Bank 1 is currently being tested. All blocks in Bank 0 have passed, and so far, there has been one failure, in Block A of Bank 1.

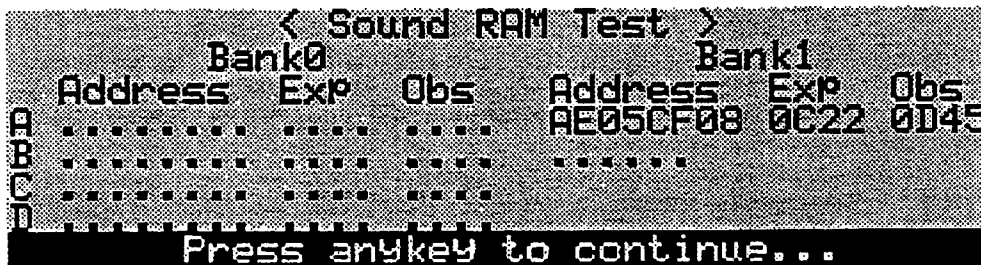

Figure 4.9. Sound RAM Test Failures

**4.14.17 1st NVRAM Test**

This memory test checks the function of the backup battery power to the non-volatile RAM (NVRAM). This test works in conjunction with the 2nd NVRAM test; you will not receive a success or failure indication at the completion of the 1st NVRAM test. Instead, you're prompted to power down the unit. Wait 60 seconds after powering down, then power up again and select and



execute the 2nd NVRAM test. If a failure is indicated, power is not being delivered from the batteries to the non-volatile RAM. Check the batteries and the connection from the batteries to the engine board.

**4.14.18 2nd NVRAM Test**

This is the second part of the non-volatile RAM test, as described in the preceding paragraph.

**4.15 DIAGNOSTIC DISPLAY MESSAGES**

Address Fail	Error in the address test stage of the memory test
Complete	Test completed
Data Fail	Error in the data test stage of the memory test
Even Fail	Error in the high byte
Fail	Test failure
Not Found	SCSI device or sound RAM not found
Odd Fail	Error in the low byte
Success	Successful test

**4.16 K2000 SCANNER DIAGNOSTICS**

This section explains the use of the K2000's scanner diagnostics, which enables confirmation of the proper function of numerous front panel buttons and controls.

The K2000 uses a separate microprocessor to scan the keyboard, read the performance controls, and operate the front panel buttons and LEDs. This processor, which is called the Scanner, then communicates its findings to the main 68301 processor (CPU). The scanner is on the Audio/Power board (at location U30) and is a single-chip, 6502-derived processor. Many potential failures and problems in the K2000 originate in devices serviced by the scanner. Thus the scanner has its own diagnostic routines to enable the tester to see directly how the keyboard, performance controls, and panel buttons/LEDs are performing.

There are two different diagnostic routines built into the scanner software. The simpler routine can be entered only at power-up and can function regardless of whether the engine board and/or LCD display is functioning properly (an engine board must still be connected to provide clock signals, however). This diagnostic routine reads out in binary format via the 8 LEDs, and consequently is called the LED Scanner diagnostic.

The other diagnostic routine can be entered at any time, and uses the LCD to display its results. Of course the engine board and LCD must be connected and functioning properly to see the results. The LCD diagnostic routine is easier to read than 8 binary-coded LEDs, so in most cases you'll want to use it rather than the LED routine.

In addition to the two selectable diagnostic routines just described, the scanner performs a number of automatic tests at power-up. If these tests are completed successfully, all 8 of the panel LEDs will flash ONCE about 1 second after power-up. If the Pitch Wheel is too far off center for full range operation, the LEDs will flash TWICE. If the battery voltage is too low for reliable memory retention, the LEDs will flash THREE times. Four flashes indicate both a low battery and an off-center Pitch Wheel.

**4.16.1 Using the LCD Scanner Diagnostic**

The LCD scanner diagnostic may be started when the K2000 is displaying its Program Page. Press the 4, 5, and 6 buttons simultaneously. The scanner will respond by lighting each LED in sequence and then displaying the following on the LCD:

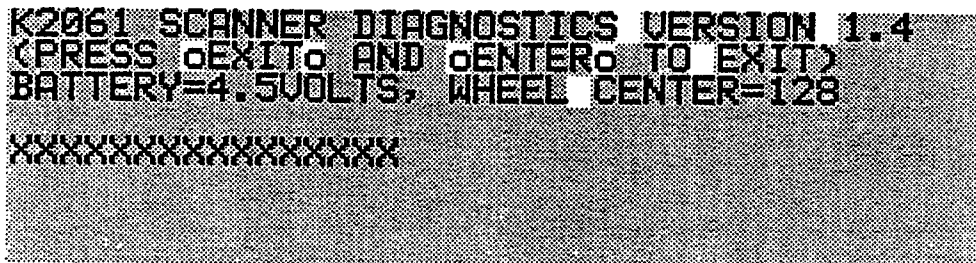

**Figure 4.10. Scanner Diagnostics**

It is possible the battery voltage and wheel center values will differ from unit to unit. Fresh batteries should read in the range of 4.3 - 4.8 volts. If the battery reading is less than 3.5 volts, it is nearing the end of its life (warnings will start to appear when it declines to 3.2 volts). The wheel center should be between 120 and 136 (inclusive) for full range operation.

The fourth line (represented by XXXX) is generally the one of interest. If it is flickering, move the right wheel toward the center. If it shows PEDAL 1 or PEDAL 2, unplug the switch pedals. Now when any button or control connected to the scanner changes, the name of that component and its most recent control value will be displayed on the fourth line. Below is a description of how the display should react to every scanned component.

- A. When the Pitch Wheel is pushed back, the display should show "PITCH WHEEL" and the numbers should smoothly increase toward 254 or 255. The numbers will move in increments of 2 or more depending on how fast the wheel is moved. If the wheel is pulled forward, the numbers should decrease toward 1 or 0, again in steps of 2 or more. When the wheel is released, the number should return to a value between 120 and 136. If the centering or range is off, there are two adjustment potentiometers on the wheel assembly that can be moved to correct the problem. If the display flickers or changes to BATTERY or CONTROL PEDAL when the Pitch Wheel is pulled full forward or pushed full back, these pots should be adjusted. A perfectly adjusted Pitch Wheel reads within 1 count of 128 in the center position, reaches 254/255 just as it hits the back stop, and reaches 0/1 just as it hits the front stop.

## SECTION 4

- B. Moving the Mod Wheel should cause the display to show "MOD WHEEL" and the numerical readout should react as with the Pitch Wheel. The range should be from 0 or 1 to 254 or 255. If the range is insufficient or reaches the 0/1 and/or 254/255 limits too soon, there are 2 more adjustment potentiometers on the Mod wheel assembly. If the display flickers or changes to BATTERY or CONTROL PEDAL when the Mod Wheel is pulled full forward or pushed full back, these pots should be adjusted.
- C. Movement of the Controller Slider will cause "DATA SLIDER" to be displayed along with a number between 0 and 255. Moving up from the down position should make the numbers increase smoothly. Unless defective, the range of the Data Slider will always be from 0/1 to 254/255.
- D. If a properly connected control pedal is plugged into the Control Pedal jack, moving it should cause "CONTROL PEDAL" to be displayed. As the pedal is rocked forward, the numbers should increase from 0/1 to 254/255. One common problem with control pedals is a range that won't go fully to zero. This can often be corrected by an internal adjustment to the pedal, either electrical or mechanical. Another common problem is non-linearity. This can be recognized by the numbers increasing much more rapidly in the higher range. Usually the only solution to this is replacement of the potentiometer inside the pedal. See the K2000 Musician's Guide Appendix I for more information about control pedal connection and testing.
- E. If a switch pedal is plugged into the Switch Pedal 1 jack, the fourth line will show "PEDAL 1" when the pedal is closed, and will go blank when it opens. Some pedals (especially Roland) are normally closed, and open only when pressed. Most others are normally open, and close when pressed. The K2000 can use either type (as long as it is plugged in before powering up) but the scanner diagnostics expect to see a normally open pedal. After testing a normally closed switch pedal, the pedal must be unplugged to clear the fourth line of the LCD. (This applies to Switch Pedal 2, also.)
- F. If a switch pedal is plugged into the Switch Pedal 2 jack, the fourth line will show "PEDAL 2" when the pedal is closed, and will go blank when it opens.
- G. If the Alpha Wheel is turned clockwise slowly, the display will show "SPIN KNOB" followed by a number that counts up (0, 1, 2, 3) and repeats. Likewise if it is turned counter-clockwise, the numbers will count down. Any other sequence indicates a problem—usually a bad connecting cable, but possibly a bad switch contact.
- H. If any button is pressed, the word "BUTTON" followed by its name will be displayed. If it is one of the mode buttons, then its associated LED will flash as well. It is normal for the LED associated with the PROGRAM button to flash more brightly than the other buttons. If several buttons have problems, the cause is usually the connecting cable. If only one button is bad, then it needs replacing. Cable problems that seem to disappear when the unit is disassembled are often due to a short circuit caused by component leads on circuit boards puncturing the cable's insulation. The ends of ribbon cable wires touching the conductive coating inside the top cover can also cause improper operation.
- I. Pressing any keyboard key down halfway will display the word "KEY" followed by the key's note name (such as C#4 for the black key immediately to the right of middle C) followed by the key's MIDI ID number (61 in this case). This indicates that the "upper contact" of the key has closed. Pressing

lightly all the way down should display the same note name and MIDI number a second time which indicates that the "lower contact" of the key has closed. The two names/numbers should match. Most keyboard errors are detected by the diagnostic which will display \*\*ERROR \*\* in response. If several keys seem to be bad, the problem is usually in the connecting cables. Note: If none of the keys responds, yet the keyboard is known to work, there may be interference from the pressure sensor. This will usually go away if the unit is allowed to cool for awhile with the power off. Units with serial numbers above 5000 should not be susceptible to this.

- J. If a keyboard key is pressed down firmly, the pressure sensing circuit will begin to respond and the display will change to "PRESSURE = XXX." "XXX" will vary between 4 and 255 according to how hard the key is pressed. When pressure drops below 4, the display switches back to the note name/number display. There is a pressure sensitivity adjustment on the audio/power board (at location R201, near the large filter capacitor) that may be changed to suit an individual customer.

NOTE: There are two additional internal signals called AUX1 and AUX 2 that are normally unused. If the fourth line ever shows "AUX 1" or "AUX 2," then there is likely a short circuit (usually to a cable running under the board) or current leakage in the audio/power board.

The LCD based diagnostic may be exited and normal K2000 operation restored by pressing the EXIT and ENTER buttons together. The K2000 should restart just as if a soft reset had occurred.

#### 4.16.2 Using the LED Scanner diagnostics

In cases where the K2000 appears to be "dead," the scanner microprocessor and user interface controls may still be functional. If the eight panel LEDs flash at all shortly after power-up, that's an indication that the scanner processor is running which in turns means that the power supply is probably functional.

To enter the LED Scanner diagnostics, press and hold the 7, 8, and 9 buttons while the power is off then turn the power on while continuing to hold them down. The panel LEDs will flash in inverse sequence to indicate entry into the LED diagnostic. After the light show, the software version number (\$14) will be shown briefly in hexadecimal, followed by the battery voltage in volts (left hex digit) and tenths (right digit). The battery voltage should remain on the display but early serial number units may display it only briefly.

The LED-based diagnostic uses the 8 mode LEDs for a two-digit hexadecimal readout. The LEDs are sequenced from top left, down the left column, to the top right, and down the right column. The values the LEDs represent are as follows: Program mode = 128 decimal (\$80 hexadecimal); Setup mode = 64 (\$40); Quick Access mode = 32 (\$20); Effects mode = 16 (\$10); MIDI mode = 8 (\$08); Master mode = 4 (\$04); Song mode = 2 (\$02); Disk mode = 1 (\$01). See Figure 4.11.

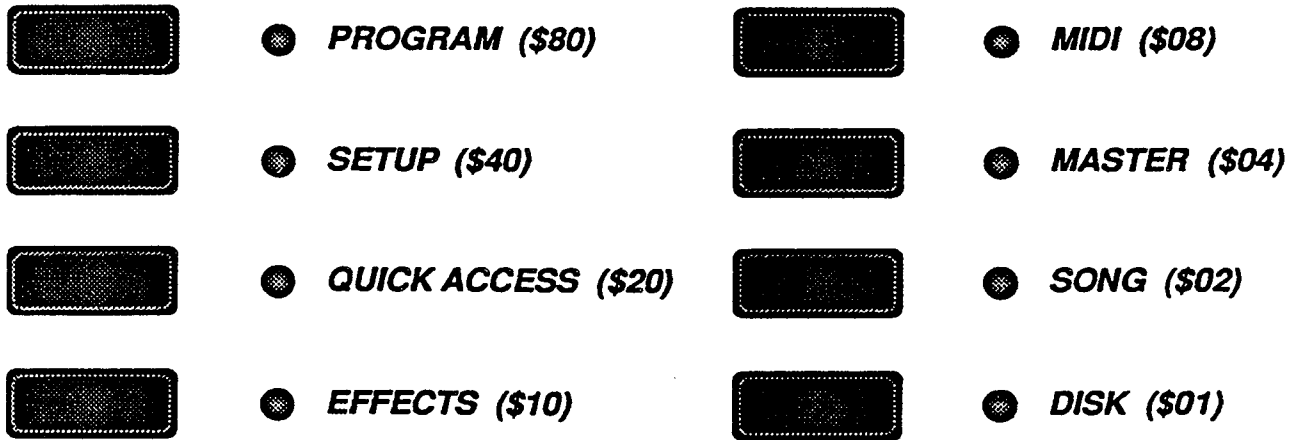

**Figure 4.11. LED values**

The value is calculated by summing the values represented by the lit LEDs. Another way to look at this is to consider the LEDs as representing a string of binary digits (bits). A lit LED represents a one(1), and an unlit LED represents a zero (0).

For example, the hexadecimal value \$A7 (167 decimal) would be represented as follows:

Program mode	On	MIDI mode	Off
Setup mode	Off	Master mode	On
Quick Access mode	On	Song mode	On
Effects mode	Off	Disk mode	On

The values of the lit LEDs are \$80 (128 decimal), \$20 (32), \$04 (4), \$02 (2), and \$01 (1), for a total of \$A7 (167). Interpreted as a binary string, the value would be 10100111.

Movement of either wheel, the Controller slider, or a control pedal causes the changed value to appear in hex on the LEDs. Although there is no direct indication of which control changed, you can assume that the control that changed physically is the one the scanner observed.

If Switch Pedal 1 is closed, the LEDs will show \$F1; if Switch Pedal 2 is closed, they will show \$F8. As with the LCD-based diagnostics, normally closed switch pedals should be unplugged except when they are being specifically tested.

Turning the large knob clockwise gives the sequence \$01-\$02-\$04-\$08-\$01-\$02.... while turning it counter-clockwise should give \$08-\$04-\$02-\$01-\$08-\$04.....

## SECTION 4

DIAGS0\_4.DOC 12/22/92

When a button is pressed, its matrix address is displayed. The hexadecimal values corresponding to each button is given below. Every button should give an indication when pressed.

\$11	CLR	\$41	3	\$71	CURSOR DOWN
\$12	0	\$42	2	\$72	CURSOR UP
\$13	Plus/Minus	\$43	1	\$73	EXIT
\$14	PROGRAM	\$44	EFFECTS	\$74	SONG
\$21	9	\$51	-	\$81	Soft D
\$22	8	\$52	+	\$82	Soft E
\$23	7	\$53	ENTER	\$83	Soft F
\$24	SETUP	\$54	MIDI	\$84	DISK
\$31	6	\$61	CURSOR RIGHT	\$91	Soft A
\$32	5	\$62	CURSOR LEFT	\$92	Soft B
\$33	4	\$63	CANCEL	\$93	Soft C
\$34	QUICK ACCESS	\$64	MASTER	\$A3	EDIT
\$A2	CHAN/BANK UP				
\$A1	CHAN/BANK DOWN				

When a key is pressed partially, its MIDI note number is displayed dimly in hexadecimal. The MIDI note numbers range from \$24 (decimal 36) for the lowest key to \$60 (decimal 96) for the highest key. Pressing the key fully should make the display brighten but otherwise not change. If the diagnostic detects an error (lower contact made but not the upper contact for example), some or all of the LEDs will blink. When the key is pressed hard enough to activate the pressure sensor, the note number display is replaced by the pressure value display.

To exit the LED-based diagnostic, power should be turned off then back on.

SECTION 4

DIAGSO\_4.DOC 12/22/92

**4.17 K2000 and K2000R DIAGNOSTICS VERSION 1.0****(K2000 WITH VERSION 1.2 ENGINE SOFTWARE)**

This document is intended only for qualified Kurzweil service technicians. It will explain how to use the K2000's and K2000R's internal diagnostic software, describing the significance of success or failure of each of the individual tests, and when applicable, the measures required to correct test failures will be given.

This document is for use with K2000 and K2000R Diagnostic software Version 1.0, which is included with K2000 and K2000R Engine software Version 1.2x. If you're working on a K2000 with Engine software 1.0, please refer to the manual for K2000 Diagnostic software Version 0.4.

Since the diagnostic software is the same for both the K2000 and K2000R, this document will only refer to the K2000. However, all information also applies to the K2000R.

**4.18 INTRODUCTION**

This introduction will explain the general structure of the diagnostic software, and the types of tests that can be performed.

**4.18.1 Diagnostic Software Structure**

Upon entering the K2000's diagnostic mode, a menu of available tests will display. The options are to run the standard Burn-in test, or to select individual tests to diagnose specific components. The Burn-in test automatically initiates a series of tests to check the basic functionality of the K2000's hardware.

There are three general types of tests: RAM, ROM, and I/O (input/output). The descriptions of each diagnostic test will identify their general types.

**4.19 USING THE K2000 DIAGNOSTIC SOFTWARE****4.19.1 Entering Diagnostic Mode**

**IMPORTANT NOTE:** Before beginning the diagnostics, be sure that the owner of the K2000 has backed up any data stored in RAM, since the diagnostics will completely clear the unit's RAM. Refer to section 13 of the Musician's Guide for details on backing up RAM.

To enter Diagnostic mode, hold the 1, 2, and 3 buttons on the alphanumeric buttonpad and turn the unit on. A special power-up menu will appear (see Figure 4.12), showing two options: HARD RESET, and DIAGNOSTICS. Use the Alpha Wheel to select the desired option, highlighting it in reverse. Then press the ENTER button to execute your choice. Selecting DIAGNOSTICS will enter the K2000's diagnostic mode. Selecting HARD RESET will reset the K2000 (erasing all RAM) and return it to Program mode. To cancel the special



power-up menu without performing a hard reset or entering diagnostics, simply turn the unit off.



Figure 4.12 - Special K2000 Power-up Options

When entering diagnostic mode, a menu of available tests appears. See Figure 4.13. The soft buttons are labeled by the bottom line of the display. The options are "1 Burn-in Test", or "2 Test Forever."



Figure 4.13 - Diagnostic Test Menu

Performing the Burn-in test on newly shipped units is recommended for a general test. If a specific problem has occurred with a particular unit, you should select the appropriate test(s) from the normal diagnostics menu. If repairs or replacement of parts are necessary, it is advised to run the Burn-in test one or more times when repairs are finished.

#### 4.19.2 Running the Burn-in Test

NOTE: Before running the Burn-in test, insert a formatted floppy disk into the K2000's floppy disk drive. The Burn-in test will hang up at the floppy drive test if you begin it without a disk in the drive.

When the diagnostic test menu is displayed, press 1 on the alphanumeric buttonpad, then press ENTER to begin the Burn-in test sequence. When you select the Burn-in test, the display changes to show the list of tests included in the Burn-in sequence. As each test is completed, the display is updated to show the result. See Figure 4.14. The Burn-in test is adequate for testing the unit's major components; if all the Burn-in tests pass, the unit should be in full working order.

NOTE: An SCSI device must be connected to the unit's SCSI port, otherwise the SCSI test will fail. This does not necessarily indicate a malfunction of the SCSI link.

```

LCD          :
Boot ROM    :
Setup ROM   :
PSRAM       :
I/O Port    :
Interrupt   :
AudioBoard  :
Floppy      :
SCSI        :
Sound ROM   :
Sound RAM   :
EXIT-Stop Diags.  Total-0000 Fail-0000

```

Figure 4.14 - Burn-in Test Menu

The Burn-in test can be aborted at any time by pressing the EXIT button, then pressing any button on the front panel to return to the diagnostic test menu (the display says "Press any key," meaning a front panel button, not one of the black-and-white keys). It may be necessary to press the EXIT button more than once, because the K2000 can only recognize switch closures between tests.

Press any front panel button to interrupt the Burn-in test temporarily. The test will resume when the button is released. Press any one of the keys, the test will be interrupted and hold temporarily; it will resume when any front panel button is pressed.

#### 4.19.3 Selecting a Specific Test

To run an individual test, use the Alpha Wheel to select the desired test from the diagnostic test menu. The selected test is highlighted in reverse. Press the ENTER button to run the selected test one time. When the test is completed, the display will show the result of the test. Normally each test need only be run once in the attempt to identify failures. If you encounter test failures, you may want to run the failed test continuously. Running a given test continuously is recommended to monitor the K2000's output signal with an oscilloscope, since many tests are completed too quickly to be monitored in a single pass.

#### 4.19.4 Continuous Testing

A selected test can be run indefinitely by pressing 2 on the alphanumeric buttonpad, then pressing ENTER. This will cause the selected test to run until it is interrupted with the EXIT button. Remember, it may be necessary to press the EXIT button more than once.

Press any front panel button to interrupt a continuous test temporarily. The test will resume when the button is released. Press any one of the keys, the test will be interrupted and hold temporarily, and will resume when any front panel button is pressed.

As the continuous tests are running, the bottom line of the display will indicate the number of tests that have been completed, and the number of failures that have occurred.

## 4.20 TEST TYPES

The tests described in this section are of three types, referred to as RAM tests, ROM tests, and I/O tests. Memory tests check the physical memory addresses of the data corresponding to various components. This is done by

writing an arbitrary test data pattern to memory and reading it back, then comparing the written data to the read data. ROM tests involve comparing the data stored in the ROM components to a checksum. I/O tests also send a test data pattern from the central processor to the component(s) being tested, and check whether the data are being exchanged properly between the central processor and the tested component(s).

**4.20.1 Memory tests**

There are two stages to a memory test: the data test, and the address test. In the data test, a test data pattern is written from the processor to the memory component being tested. The diagnostic software expects the data pattern that's written to memory to be read back exactly as it was written. If this is the case, the test passes. If the observed data (the data read from memory) differ from the expected data (the data written to memory), the test fails.

When a data failure occurs, it is displayed in the following format: the memory address where the failure occurred; the expected hex value at that address; the actual observed value at that address. See Figure 4.15 for an example.



**Figure 4.15 - Data Failure**

In the address test, the central processor (CPU—a Motorola 68301) checks every memory address related to the component being tested. A test data pattern is written to each address, and then read back. The diagnostic software expects the data pattern to be read back from the same address to which it was sent. If the observed address (the address read from) matches the expected address (the address written to), the test passes. If the observed address does not match the expected address, the test fails. Address failures are displayed in the following format: the expected address; the observed address. See Figure 4.16 for an example.

NOTE: Many figures in this document show values of all zeros. You'll see non-zero values for the address, expected values, and observed values of all tests. The expected and observed values themselves are not significant; what's important is that a difference between the expected and observed values indicates a test failure.

```
Test Item : PSRAM
Please wait. Testing...Addr Err
Expected: 00000000
Observed: 00000000
Press anykey to continue...
```

Figure 4.16 Address Failure

#### 4.20.2 ROM Tests

Since data cannot be written to ROM components, tests are done by reading the data from the ROM components and summing the hexadecimal values of the data. This sum is compared to a checksum stored in the last two memory addresses of each component. The two sums must match for the test to pass.

#### 4.20.3 I/O Tests

In an I/O test, a test data pattern is sent from the CPU to the component being tested. The signal is processed by the component, and returned to the central processor. If the signal returns to the central processor as expected, the test is a success. If the observed pattern differs from the expected pattern, the test fails.

Each of the tests described below will be either a memory test or an I/O test (or, in some cases, a combination of the two). When performing single passes of specific tests, the display will indicate the result of the test upon its completion. In most cases, the result will be Success (Pass), Data Fail, or Address Fail. Unless otherwise specified, failures will be displayed as described in the previous paragraphs.

### 4.21 DESCRIPTIONS OF TESTS

#### 4.21.1 LCD Test

This test has both an I/O stage and a memory stage. It checks the connections between the LCD and the engine board, as well as the memory of the LCD itself.

The processor writes a test data pattern to the LCD memory, then reads it back expecting a certain value. If the observed value does not match the expected value, a data failure is indicated. This could indicate a processor error, a faulty LCD, or a faulty connection from the LCD to the engine board.

#### 4.21.2 Boot EPROM Test

This memory test checks the integrity of the Engine software data stored in the ROM chips located on the engine board at U3 and U6. It reads the data

from each address and compares it to a checksum stored in the ROM chips. It also checks for errors in the pin connections of each of these chips. If all checksums match, the test is a success. If there are checksums that do not match, the display will show either "Even Fail" or "Odd Fail." If an Even Fail message appears, remove the chip located at U3 and test it in an EPROM programmer. If the checksums match, the chip is good, and a connection problem at U3 is indicated. If the checksums do not match the chip is improperly programmed and should be reprogrammed or replaced. Likewise, if an Odd Fail message appears, remove and test the chip from location U6.

**NOTE:** The sockets at U3 and U6 are labeled "SETUP" on the engine board. Even so, the chips installed in these sockets are the Engine software EPROMs. This discrepancy is due to a design change that was made after the engine board was finalized and printed. For Engine software Version 1.1 and 1.2, the SETUP sockets contain the Engine software, and locations U2 and U5 are unused. Nevertheless, the Boot EPROM test checks the Engine software EPROMs.

#### **4.21.3 Setup EPROM Test**

Similar to the Boot EPROM test, this is intended to check the data and pin connections of the ROM chips located at U2 and U5 on the engine board. For Engine software Version 1.1 and 1.2, these locations are unused, and the test will fail. This does not indicate a malfunction.

#### **4.21.4 PSRAM Test**

This is a memory test of the pseudo-static RAM chips located at U7 and U8 on the engine board. The results will be either Success, Data Failure, or Address Failure. If this test fails, the RAM chips should be replaced. If unit has the P/RAM option, the test will take approximately 45 seconds to run. Without the P/RAM extension, the test takes approximately 11 seconds.

**NOTE:** This test checks only to ascertain whether the pseudo-static RAM chips at U7 and U8 are good. It does not check to determine if the memory in the P/RAM option (if installed) is good. To check whether the extra RAM is recognized by the unit, it is necessary to enter Song mode or Disk mode when finished with the diagnostics. The top line of the display will indicate the amount of available RAM. This number should be approximately 120K if there is no P/RAM extension, and approximately 760K with the P/RAM extension. If the unit has the P/RAM option board (at connector J1), the display should show the additional RAM space. If the display does not indicate approximately 760K of available RAM, the P/RAM option board may be defective, and should be repaired or replaced.

#### **4.21.5 I/O Port Test**

In this test, the integrity of data transfer within the CPU (location U9) is tested. This is done by writing a test data pattern from the low bit addresses of the CPU to the high bit addresses. The high bits then read the pattern and compare it to the original. If the patterns match, the test is a success. If the test fails, the CPU may be bad, but it is more likely that there is a problem with the I/O bus.

#### **4.21.6 Interrupt Test**

Also an I/O test, the Interrupt Test checks the connection between the IRQ0 (interrupt request) pin and the floppy disk controller in the CPU. A successful Interrupt test indicates that interrupt requests from the floppy

disk controller are being received by the CPU's IRQ0 pin. Failure of this test indicates a defective connection between the CPU's IRQ0 pin and floppy disk controller, and could identify the cause of malfunctions in the floppy disk drive.

#### **4.21.7 Audio Board Test**

Another I/O test, this checks the connections between the engine and audio boards. When you run this test, the LCD will always display "Success," but this should be ignored, since it doesn't indicate the success or failure of the test. In a successful test, the eight LEDs to the left of the LCD will flash in sequence (from top left to bottom left to top right to bottom right) at 300 ms intervals. A failure of any of the LEDs to light indicates a defective LED or a faulty connection between the engine and audio boards.

#### **4.21.8 MIDI UART Test**

This I/O test checks the operation of the MIDI In and Out ports. Before executing this test, connect a MIDI cable from the K2000's MIDI Out port to its MIDI In port. A failure of this test is indicated in the display as a data failure as described in the overview. If this test fails, repeat the test with a different cable. If it still fails, this indicates that one or more pins in the MIDI Out and/or MIDI In port is defective.

#### **4.21.9 FDC Test**

**A blank formatted floppy disk (DOS 1.4M) must be inserted in the floppy disk drive before initiating this test. The test cannot proceed without a disk inserted in the drive.**

The FDC (floppy disk controller) test is an I/O test, and checks the functionality of the NEC PD72064 chip, the floppy disk drive, and their connections. The test entails sending a test data pattern from the floppy disk controller (FDC) to the floppy disk drive (FDD) and back. If the display indicates a successful test, then the connections between the FDC and FDD are functioning, and the test data pattern written by the FDC and read from the FDD are identical. If the display indicates "Read Fail," there is a problem in the connection from the FDC to the FDD. If it indicates "Write Fail," there is a problem in the connection from the FDD to the FDC. If the display indicates "Data Fail," the read and write operations are normal, but the "read" signal and the "write" signal do not match. In this case, the display will indicate a data failure as described in the overview.

#### **4.21.10 SCSI Test**

This I/O test is similar to the FDC test, and checks the functionality of the SCSI port. If no SCSI device is connected to the unit's SCSI port, this test will fail. This does not necessarily indicate a malfunction of the SCSI link. To be sure that the SCSI link is operational, you should connect a SCSI device before running this test.

#### **4.21.11 Calvin and Hobbes Tests**

The 13-step Calvin and Hobbes memory test checks the connections between the CPU and the three VLSI sound engine chips: Calvin, Hobbes 0, and Hobbes 1. Calvin handles sample fetching tasks, and Hobbes 0 and 1 primarily perform wave form generation and DSP functions.

Calvin and Hobbes have undergone rigorous testing prior to mass manufacturing, and are extremely unlikely to be defective. If one or more of the steps in this test indicate a failure, the problem is probably to be found in the connections between the chips and the CPU. The test results are displayed as shown in Figure 4.17. The significance of failures in each step of the test is explained below. Steps 2.1-2.3 test the connections to the internal RAM and internal registers of Calvin and Hobbes.

When analyzing the results of these tests, you're looking for a PASS message for each test. The hexadecimal numbers that appear on the display are irrelevant as long as they match for each test. The numbers shown in figure 5.16 are arbitrary, and may differ from the numbers you see in the unit you're testing. This does not indicate a problem.

If any of the tests fails, check the connections between the components in question, as described in the paragraphs below. If test #2 fails, check all the connections between the CPU, Calvin, Hobbes 0, and Hobbes 1. Note that expected observed values are not given on the line indicating the status of test #2. Instead, a PASS or FAIL message will be indicated for each of the three steps in test #2.

NOTE: The Calvin and Hobbes tests are interrelated, and are sequenced from the least significant test to the most significant. If any one test fails, the subsequent tests are likely to fail as well. In this case, start by checking the components related to the first test that failed. If a malfunction occurs, repair the malfunction and run the Calvin and Hobbes test again. It is likely the subsequent tests will pass when retested.

In general, the data flow through these components is the following sequence: Sample memory, Calvin, Hobbes 0, Hobbes 1. If test failures occur, check the connections to Calvin before checking those to Hobbes 0, and Hobbes 0 before Hobbes 1.

No	Res	Exp	Obs	No	Res	Exp	Obs
1	PASS			7	PASS	AB53	AB53
2	PASS	PASS	PASS	8	PASS	09FB	09FB
3	PASS	33D0	33D0	9	PASS	852C	852C
4	PASS	0D80	0D80	A	PASS	3049	3049
5	PASS	0D80	0D80	B	PASS	6789	6789
6	PASS	0A04	0A04				

Press anykey to continue...

Figure 4.17 Calvin and Hobbes Test

- 1           Checksum is different in Calvin CROM  
            Connection problem between CPU and Calvin
- 2.1        Calvin Memory Test Fail  
            Connection problem between CPU and Calvin
- 2.2        Hobbes 0 Memory Test Fail  
            Connection problem between CPU and Hobbes 0

- 2.3     **Hobbes 1 Memory Test Fail**  
          Connection problem between CPU and Hobbes 1
- 3       **Calvin Sample Memory Checksum Test Fail**  
          Connection problem between Calvin and sample memory
- 4       **Hobbes 0 Input Unit Holder Register Checksum Test Fail**  
          Connection problem between Calvin and Hobbes 0
- 5       **Hobbes 1 Input Unit Holder Register Checksum Test Fail**  
          Connection problem between Calvin and Hobbes 1
- 6       **Calvin Memory Checksum Test Fail**  
          Connection problem between Calvin and CPU, or between Calvin  
          and Sample memory
- 7       **Hobbes 0 Memory Checksum Test Fail**  
          Connection problem between Calvin and Hobbes 0
- 8       **Hobbes 1 Memory Checksum Test Fail**  
          Connection problem between Hobbes 0 and Hobbes 1
- 9       **Calvin Read Only Checksum Test Fail**  
          Connection problem between Calvin and Hobbes 0
- A       **Hobbes 0 Read Only Test Fail**  
          Connection problem between Calvin and Hobbes 0
- B       **Hobbes 1 Read Only Test Fail**  
          Connection problem between Hobbes 0 and Hobbes 1

#### 4.21.12     **Sampling Option Test**

This test is relevant only if the sampling option has been installed in the unit under test. If no sampling board is present, this test will fail. This test is only necessary when the sampling option has been installed.

The "five-step sampling option test" checks the integrity of the sampling option board and its connections to the CPU. The five steps check the following items:

- 1     Noise and distortion, clock test
- 2     Audio level overload test
- 3     Gain test
- 4     Input jack test
- 5     Digital I/O test

If there is a failure in any of the five steps, the LCD will show a failure for the entire test. In this case you should check the connections of the sampling option board. When done, run the test again. If it fails again, replace the sampling option board.



**4.21.13 Sine Wave Test**

Executing this test enables generation of sine waves at the following frequencies: 20 Hz, 315 Hz, 630 Hz, 945 Hz, 1260 Hz, 2 KHz, 4 KHz, and 8 KHz. The sine wave at 20 Hz is generated as soon as the test is initiated. Pressing any button on the front panel (or turning the Alpha Wheel one click to the right) will generate the next-highest frequency. The unit will return to the diagnostic test menu when the sine wave is at 8 KHz and any front panel button is pressed or the Alpha Wheel is clicked to the right.

This test is intended for use with an oscilloscope connected to the K2000's audio output, and enables analysis of the purity of the sine wave generated. If the sine wave is impure, a problem with the sound engine is suggested. To monitor the Sine wave test, connect the scope to any of the B outputs, the MIX outputs, or the Headphone jack.

**4.21.14 Sound ROM Test**

This memory test takes about five seconds to run, and checks the data integrity of the K2000's sound ROM (the factory sounds), and the connections between the sound ROM and the CPU. The test is a simple checksum procedure for each pair of Sound ROM chips. Failures are indicated as data or address failures, as described in the overview. The display indicates the success or failure of each of the four blocks of Sound ROM (A-D). Each block corresponds to two Sound ROM chips. In the unlikely event of a failure, the engine board must be replaced, since the Sound ROM chips are soldered in place.

**4.21.15 Sound RAM Test**

This memory test checks the address space of the sample RAM (SIMMs). The purpose of this test is to determine whether the K2000 recognizes all of the sample RAM that has been installed. The more RAM that has been installed, the longer this test takes. The test takes approximately 20 seconds for each Megabyte of RAM.

The K2000's sample RAM space is divided into two banks (Bank 0 and Bank 1), representing the two pairs of SIMM sockets. Each bank is divided arbitrarily into four blocks with a maximum address space of 8Mb. These blocks, A-D, represent internal divisions of the address space; and do not correspond to any physical division of the sample RAM.

When the Sound RAM test is run, the display will indicate which block in which bank is currently being tested. This is shown by a series of dots that appear as the test proceeds. As each block is finished, the dots are replaced with either a success message (OK) or a failure message. If the block fails, the malfunctioning address is indicated, as well as the expected checksum value and the observed value. See Figure 4.18.

Each of the eight blocks corresponds to 8Mb of available RAM. The number and size of the SIMMs installed in the unit determine which blocks are used. For example, assume two pairs of 4Mb SIMMs are installed; thus 4Mb x 4, or 16Mb of sample RAM. If the Sound RAM test is executed, and all RAM is recognized, the display will show "8.0M Found" in Block A of each bank when the test finished.

The sample screen shown in Figure 5.17 indicates that there are 2 Mb of RAM installed in Bank 0 (two 1Mb SIMMs). The test is currently checking Block C of Bank 1.

```

< Sound RAM Test >
      Bank0
Address Exp Obs   Address Exp Obs
A 2.0M Found... ..
B Nothing  ....
C Nothing  ....
D Nothing  ....
Press anykey to continue...

```

Figure 4.18 - Sound RAM Test (currently checking Bank 1, Block C)

As a final example, suppose a pair of 1Mb SIMMs is installed in the sockets corresponding to Bank 0, and a pair of 4Mb SIMMs in the sockets corresponding to Bank 1. At the end of the Sound RAM Test, if all RAM is recognized, the display will show "2.0M Found" in Block A of Bank 0. It would also show "8.0M Found" in Block A of Bank 1. All other blocks would indicate "Nothing."

If any of the SIMMs is defective, or installed improperly, the display will indicate a data failure or address failure as described in the overview. A failure may also indicate a faulty connection between the Sound RAM and the engine board. See Figure 4.19 for an example of a failure message. In this example, Block B of Bank 1 is currently being tested. There is no RAM installed in Bank 0, and so far, there has been one failure, in Block A of Bank 1.

```

< Sound RAM Test >
      Bank0
Address Exp Obs   Address Exp Obs
A Nothing  ....
B Nothing  ....
C Nothing  ....
D Nothing  ....
AE05CF08 0C22 0D45
Press anykey to continue...

```

Figure 4.19 - Sound RAM Test Failures

#### 4.21.16 1st NVRAM Test

This memory test checks the function of the backup battery power to the non-volatile RAM (NVRAM). This test works in conjunction with the 2nd NVRAM test; no success or failure will be indicated at the completion of the 1st NVRAM test. Instead, the tester will be prompted to power down the unit. Wait 60 seconds after powering down, then press and hold the 1, 2, and 3 buttons while powering up again. Return to diagnostics mode and select and execute the 2nd NVRAM test. If a failure is indicated, power is not being

delivered from the batteries to the non-volatile RAM. Check the batteries and the connection from the batteries to the engine board.

#### 4.21.17 2nd NVRAM Test

This is the second part of the non-volatile RAM test, as described in the preceding paragraph.

### 4.22 DIAGNOSTIC DISPLAY MESSAGES

Address Fail	Error in the address test stage of the memory test
Complete	Test completed
Data Fail	Error in the data test stage of the memory test
Even Fail	Error in the high byte
Fail	Test failure
Not Found	SCSI device or sound RAM not found
Odd Fail	Error in the low byte
Success	Successful test

### 4.23 K2000 SCANNER DIAGNOSTICS

This section explains the use of the K2000's scanner diagnostics, which enables confirmation of the proper function of numerous front panel buttons and controls.

The K2000 uses a separate microprocessor to scan the keyboard, read the performance controls, and operate the front panel buttons and LEDs. This processor, which is called the Scanner, then communicates its findings to the main 68301 processor (CPU). The scanner is on the Audio/Power board (at location U30) and is a single-chip, 6502-derived processor. Many potential failures and problems in the K2000 originate in devices serviced by the scanner. Thus the scanner has its own diagnostic routines to enable the tester to see directly how the keyboard, performance controls, and panel buttons/LEDs are performing.

There are two different diagnostic routines built into the scanner software. The simpler routine can be entered only at power-up and can function regardless of whether the engine board and/or LCD display is functioning properly (an engine board must still be connected to provide clock signals, however). This diagnostic routine reads out in binary format via the 8 LEDs, and consequently is called the LED Scanner diagnostic.

The other diagnostic routine can be entered at any time, and uses the LCD to display its results. Of course the engine board and LCD must be connected and functioning properly to see the results. The LCD diagnostic routine is easier to read than 8 binary-coded LEDs, so in most cases you'll want to use it rather than the LED routine.

In addition to the two selectable diagnostic routines just described, the scanner performs a number of automatic tests at power-up. If these tests are

completed successfully, all 8 of the panel LEDs will flash ONCE about 1 second after power-up. If the Pitch Wheel is too far off center for full range operation, the LEDs will flash TWICE. If the battery voltage is too low for reliable memory retention, the LEDs will flash THREE times. Four flashes indicate both a low battery and an off-center Pitch Wheel.

**4.23.1 Using the LCD Scanner Diagnostic**

The LCD scanner diagnostic may be started when the K2000 is displaying its Program Page. Press the 4, 5, and 6 buttons simultaneously. The scanner will respond by lighting each LED in sequence and then displaying the following on the LCD:

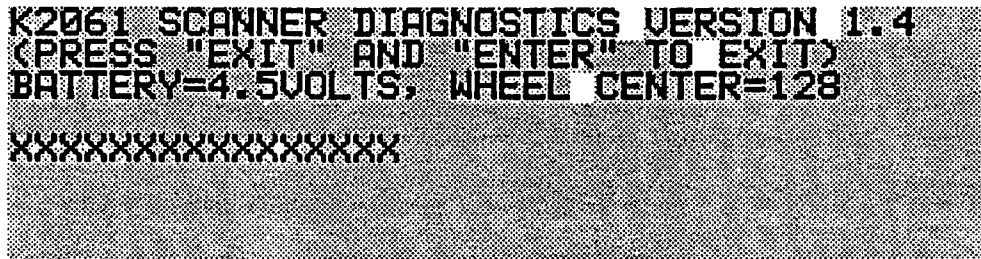

**Figure 4.20 Scanner Diagnostics**

It is possible the battery voltage and wheel center values will differ from unit to unit. Fresh batteries should read in the range of 4.3 - 4.8 volts. If the battery reading is less than 3.5 volts, it is nearing the end of its life (warnings will start to appear when it declines to 3.2 volts). The wheel center should be between 120 and 136 (inclusive) for full range operation.

The fourth line (represented by XXXX) is generally the one of interest. If it is flickering, move the right wheel toward the center. If it shows PEDAL 1 or PEDAL 2, unplug the switch pedals. Now when any button or control connected to the scanner changes, the name of that component and its most recent control value will be displayed on the fourth line. Below is a description of how the display should react to every scanned component.

- A. When the Pitch Wheel is pushed back, the display should show "PITCH WHEEL" and the numbers should smoothly increase toward 254 or 255. The numbers will move in increments of 2 or more depending on how fast the wheel is moved. If the wheel is pulled forward, the numbers should decrease toward 1 or 0, again in steps of 2 or more. When the wheel is released, the number should return to a value between 120 and 136. If the centering or range is off, there are two adjustment potentiometers on the wheel assembly that can be moved to correct the problem. If the display flickers or changes to BATTERY or CONTROL PEDAL when the Pitch Wheel is pulled full forward or pushed full back, these pots should be adjusted. A perfectly adjusted Pitch Wheel reads within 1 count of 128 in the center position, reaches 254/255 just as it hits the back stop, and reaches 0/1 just as it hits the front stop.
- B. Moving the Mod Wheel should cause the display to show "MOD WHEEL" and the numerical readout should react as with the Pitch Wheel. The range should be from 0 or 1 to 254 or 255. If the range is insufficient or reaches the

0/1 and/or 254/255 limits too soon, there are 2 more adjustment potentiometers on the Mod wheel assembly. If the display flickers or changes to BATTERY or CONTROL PEDAL when the Mod Wheel is pulled full forward or pushed full back, these pots should be adjusted.

- C. Movement of the Controller Slider will cause "DATA SLIDER" to be displayed along with a number between 0 and 255. Moving up from the down position should make the numbers increase smoothly. Unless defective, the range of the Data Slider will always be from 0/1 to 254/255.
- D. If a properly connected control pedal is plugged into the Control Pedal jack, moving it should cause "CONTROL PEDAL" to be displayed. As the pedal is rocked forward, the numbers should increase from 0/1 to 254/255. One common problem with control pedals is a range that won't go fully to zero. This can often be corrected by an internal adjustment to the pedal, either electrical or mechanical. Another common problem is non-linearity. This can be recognized by the numbers increasing much more rapidly in the higher range. Usually the only solution to this is replacement of the potentiometer inside the pedal. See the K2000 Musician's Guide Appendix I for more information about control pedal connection and testing.
- E. If a switch pedal is plugged into the Switch Pedal 1 jack, the fourth line will show "PEDAL 1" when the pedal is closed, and will go blank when it opens. Some pedals (especially Roland) are normally closed, and open only when pressed. Most others are normally open, and close when pressed. The K2000 can use either type (as long as it is plugged in before powering up) but the scanner diagnostics expect to see a normally open pedal. After testing a normally closed switch pedal, the pedal must be unplugged to clear the fourth line of the LCD. (This applies to Switch Pedal 2, also.)
- F. If a switch pedal is plugged into the Switch Pedal 2 jack, the fourth line will show "PEDAL 2" when the pedal is closed, and will go blank when it opens.
- G. If the Alpha Wheel is turned clockwise slowly, the display will show "SPIN KNOB" followed by a number that counts up (0, 1, 2, 3) and repeats. Likewise if it is turned counter-clockwise, the numbers will count down. Any other sequence indicates a problem—usually a bad connecting cable, but possibly a bad switch contact.
- H. If any button is pressed, the word "BUTTON" followed by its name will be displayed. If it is one of the mode buttons, then its associated LED will flash as well. It is normal for the LED associated with the PROGRAM button to flash more brightly than the other buttons. If several buttons have problems, the cause is usually the connecting cable. If only one button is bad, then it needs replacing. Cable problems that seem to disappear when the unit is disassembled are often due to a short circuit caused by component leads on circuit boards puncturing the cable's insulation. The ends of ribbon cable wires touching the conductive coating inside the top cover can also cause improper operation.
- I. Pressing any keyboard key down halfway will display the word "KEY" followed by the key's note name (such as C#4 for the black key immediately to the right of middle C) followed by the key's MIDI ID number (61 in this case). This indicates that the "upper contact" of the key has closed. Pressing lightly all the way down should display the same note name and MIDI number a second time which indicates that the "lower contact" of the key has closed. The two names/numbers should match. Most keyboard errors are

detected by the diagnostic which will display **\*\*ERROR \*\*** in response. If several keys seem to be bad, the problem is usually in the connecting cables. Note: If none of the keys responds, yet the keyboard is known to work, there may be interference from the pressure sensor. This will usually go away if the unit is allowed to cool for awhile with the power off. Units with serial numbers above 5000 should not be susceptible to this.

- J. If a keyboard key is pressed down firmly, the pressure sensing circuit will begin to respond and the display will change to "PRESSURE = XXX." "XXX" will vary between 4 and 255 according to how hard the key is pressed. When pressure drops below 4, the display switches back to the note name/number display. There is a pressure sensitivity adjustment on the audio/power board (at location R201, near the large filter capacitor) that may be changed to suit an individual customer.

NOTE: There are two additional internal signals called AUX1 and AUX 2 that are normally unused. If the fourth line ever shows "AUX 1" or "AUX 2," then there is likely a short circuit (usually to a cable running under the board) or current leakage in the audio/power board.

The LCD based diagnostic may be exited and normal K2000 operation restored by pressing the EXIT and ENTER buttons together. The K2000 should restart just as if a soft reset had occurred.

#### 4.23.2 Using the LED Scanner diagnostics

In cases where the K2000 appears to be "dead," the scanner microprocessor and user interface controls may still be functional. If the eight panel LEDs flash at all shortly after power-up, this indicates the scanner processor is running which in turns means that the power supply is probably functional.

To enter the LED Scanner diagnostics, press and hold the 7, 8, and 9 buttons while the power is off then turn the power on while continuing to hold them down. The panel LEDs will flash in inverse sequence to indicate entry into the LED diagnostic. After the light show, the software version number (\$14) will be shown briefly in hexadecimal, followed by the battery voltage in volts (left hex digit) and tenths (right digit). The battery voltage should remain on the display but early serial number units may display it only briefly.

The LED-based diagnostic uses the 8 mode LEDs for a two-digit hexadecimal readout. The LEDs are sequenced from top left, down the left column, to the top right, and down the right column. The values the LEDs represent are as follows: Program mode = 128 decimal (\$80 hexadecimal; Setup mode = 64 (\$40); Quick Access mode = 32 (\$20); Effects mode = 16 (\$10); MIDI mode = 8 (\$08); Master mode = 4 (\$04); Song mode = 2 (\$02); Disk mode = 1 (\$01). See Figure 4.21.

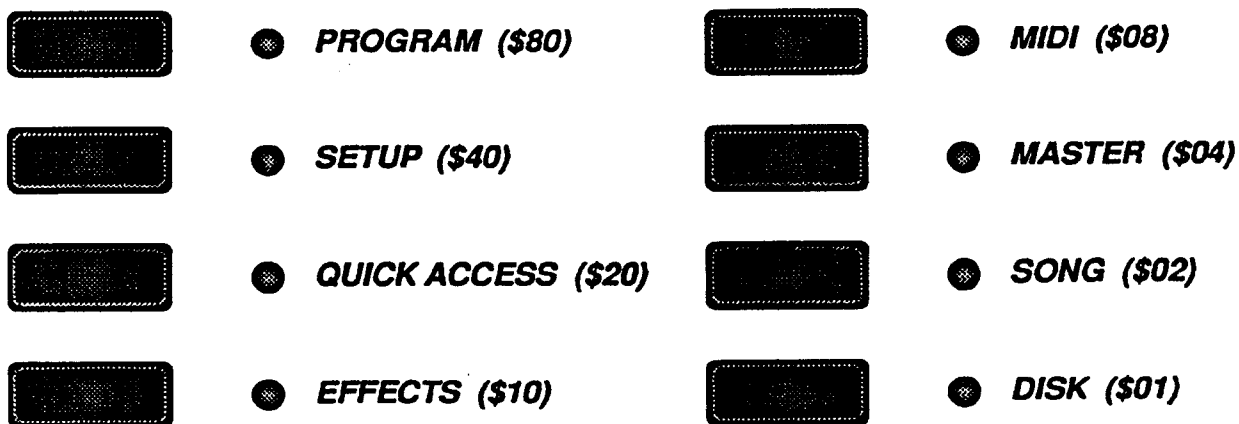

Figure 4.21 - LED values

The value is calculated by summing the values represented by the lit LEDs. Another way to look at this is to consider the LEDs as representing a string of binary digits (bits). A lit LED represents a one(1), and an unlit LED represents a zero (0).

For example, the hexadecimal value \$A7 (167 decimal) would be represented as follows:

Program mode	On	MIDI mode	Off
Setup mode	Off	Master mode	On
Quick Access mode	On	Song mode	On
Effects mode	Off	Disk mode	On

The values of the lit LEDs are \$80 (128 decimal), \$20 (32), \$04 (4), \$02 (2), and \$01 (1), for a total of \$A7 (167). Interpreted as a binary string, the value would be 10100111.

Movement of either wheel, the Controller slider, or a control pedal causes the changed value to appear in hex on the LEDs. Although there is no direct indication of which control changed, you can assume that the control that changed physically is the one the scanner observed.

If Switch Pedal 1 is closed, the LEDs will show \$F1; if Switch Pedal 2 is closed, they will show \$F8. As with the LCD-based diagnostics, normally closed switch pedals should be unplugged except when they are being specifically tested.

Turning the large knob clockwise gives the sequence \$01-\$02-\$04-\$08-\$01-\$02.... while turning it counter-clockwise should give \$08-\$04-\$02-\$01-\$08-\$04.....

## SECTION 4

When a button is pressed, its matrix address is displayed. The hexadecimal values corresponding to each button is given below. Every button should give an indication when pressed.

\$11	CLR	\$41	3	\$71	<?>
\$12	0	\$42	2	\$72	<?>
\$13	Plus/Minus	\$43	1	\$73	EXIT
\$14	PROGRAM	\$44	EFFECTS	\$74	SONG
\$21	9	\$51	-	\$81	Soft D
\$22	8	\$52	+	\$82	Soft E
\$23	7	\$53	ENTER	\$83	Soft F
\$24	SETUP	\$54	MIDI	\$84	DISK
\$31	6	\$61	<?>	\$91	Soft A
\$32	5	\$62	<?>	\$92	Soft B
\$33	4	\$63	CANCEL	\$93	Soft C
\$34	QUICK ACCESS	\$64	MASTER	\$A3	EDIT

When a key is pressed partially, its MIDI note number is displayed dimly in hexadecimal. The MIDI note numbers range from \$24 (decimal 36) for the lowest key to \$60 (decimal 96) for the highest key. Pressing the key fully should make the display brighten but otherwise not change. If the diagnostic detects an error (lower contact made but not the upper contact for example), some or all of the LEDs will blink. When the key is pressed hard enough to activate the pressure sensor, the note number display is replaced by the pressure value display.

To exit the LED-based diagnostic, power should be turned off then back on.



**SECTION 4**

**4.24 K2000R MAINTENANCE AND CARE**

- 4.24.1 As with the K2000, with minimum of care the K2000R will provide years of reliable enjoyment. Please follow the following points to maintain the K2000R at peak performance. To avoid redundancy, the maintenance tips for the K2000 and K2000R remain the same, thus this section will only detail those areas that are graphically different and require a different approach.
- 4.24.2 Proper installation is essential to the health and welfare of the K2000R. It should rest on a stable and level flat surface using the "feet" supplied in the kit and with adequate ventilation above and below the unit...OR in a proper rack mount arrangement making certain to provide the same ventilation space.
- 4.24.3 Remember, there are no user-serviceable parts in the K2000R. Under no circumstances should anyone other than a qualified technician attempt to remove any panels from the unit, except for battery replacement. Any attempt to open the K2000R risks severe electrical shock and may void the product warranty.

**4.25 Cleaning the K2000R**

- 4.25.1 Refer to paragraph 4.1.1 for cleaning details. Ignore any reference to keyboard because the K2000R is not so equipped. DO NOT REMOVE ANY PANELS! DO NOT USE STRONG CLEANERS OR SPRAY ANYTHING ON THE FRONT PANEL OR INTO VENTILATION HOLES!

**4.26 Floppy Drive Maintenance**

- 4.26.1 Refer to paragraph 4.2.1 for details and to section 3.3 for access information.

**4.27 Battery Selection and Replacement**

- 4.27.1 The K2000R uses three AAA batteries (1.5V) to preserve its internal memory when the power is turned off. The original batteries should last at least one year before they need replacing. Replacement is necessary when the LCD says "BATTERY VOLTAGE IS LOW" during power-up, or when it is noticed the LEDs flash twice instead of once during power-up. Once these warnings begin to occur, the batteries should be replaced within a couple of weeks to ensure continued safety of the RAM entries.
- 4.27.2 To replace the batteries, simply orient the unit such that the rear panel is accessible, particularly the lower right corner of the rear panel.
- Locate the round battery cover and, using a coin, rotate the cover counter-clockwise 1/4 turn. It will naturally eject itself into the hand because the batteries are spring loaded.
  - Remove the batteries (3) and replace. NOTE: It may be necessary to slightly tilt the body of the K2000R toward the rear to remove the remaining two batteries. When replacing the batteries, be certain to install them with the positive tip toward the rear of the unit.

## SECTION 4

KZRMINT.DOC 01/05/93

### 4.28 User Callable Diagnostics

4.28.1 Refer to paragraph 4.4 on page 2 of this section for details.

### 4.29 Maximizing Music and Minimizing Noise

4.29.1 Refer to paragraph 4.5 on page 4 of this section for details.

### 4.30 Ground Hum

4.30.1 Refer to paragraph 4.6 on page 5 of this section for details.

### 4.31 Power Problems and Solutions

4.31.1 Refer to paragraph 4.7 on page 6 of this section for details.

**NOTE:** For troubleshooting and diagnostic information please refer to sections 4.8 and subsequent for details.

**Kurzweil K2000/K2000R**  
**Version 1.30 Software**

- A New Operating System For K2000 Keyboards and K2000R Rack Mounts
- Includes All New Programs, Setups and Quick Access Banks

**NEW FEATURES**

- **SMDI** (transfers sample sata over high speed SCSI)
- **Channel Count** (control parameter for number of active voices)
- **Bend Smooth** (for use with MIDI guitar controllers)
- **Stereo Samples Support** (stereo samples now treated as single object)
- **Import Layers Function** (indicates composition of layers)
- **On-Line Diagnostics and Hard Reset Functions**

**ALSO:**

- Supports new Kurzweil P-RAM Program Ram; Memory Expansion
- Improved Program Mode and Quick Access Operation
- New levels of Reliability and Operational Convenience

# K2000/K2000R OPTIONS

**NOTE: ANY K2000/K2000R TO RECEIVE ANY OF THE OPTIONS BELOW MUST FIRST BE EQUIPPED WITH THE KURZWEIL DFK-1 FAN KIT. The DFK-1 Fan Kit includes all necessary cables and hardware to install a low noise fan into K2000s and K2000Rs.**

- **SIMM SAMPLING MEMORY MODULES** - can be of the following sizes: 256K, 1M, 2M, 4M, 8M, and 16M. The K2000/K2000R can accommodate up to 64 megabytes of dynamic RAM for the purpose of loading and processing samples. **NOTE: If you use any SIMMs (Single In-line Memory Module) larger than 4M, please contact Kurzweil/Young Chang America for the latest information on approved chips and sources. This is very important.**
- **INTERNAL HARD DRIVE** - only Kurzweil approved SCSI hard disk drives may be used. **NOTE: Installation of an internal Hard Drive will require the DHDC-1 Installation Kit.** The following are the current KMS tested and approved drives:
  - **Quantum:** LPS52S, 105S, 120S, 210S, 240S  
ELS42, 85, 127, 170
  - **CONNER:** 30100, CP3040, C85/170/212
  - **SEAGATE:** ST3600N (K2000R only)
  - **SYQUEST:** 44/88Meg (external)
  - **FUJITSU:** 261X series - 330, 420, 520 (Note: may require jumper change for proper operation)
- Kurzweil cannot guarantee that other hard disk drives will be compatible with the K2000's connectors, that they will operate properly with K2000 software, or that they conform to power consumption and heat generations limitations.
- Call Kurzweil for further information on approved drives.
- **DHDC-1/DHDC-2 HARD DISK CABLE KITS** - include all hardware necessary to install and connect one of the Kurzweil-approved internal hard disk drives to the K2000 (HDC-1) or K2000R (HDC-2). **NOTE: A hard drive is not included in these kits.**

- **DSMP-K/DSMP-R SAMPLING OPTION** - NOTE: DSMP-K is for the K2000 Keyboard and the DSMP-R is for the K2000R Rack Mount unit. This option enables the K2000 to sample via analog stereo 1/4" line level input and digital inputs accommodating three digital formats: AES-EBU and S/PDIF formats only.
- **DROM-1 OR DROM-2 SOUND BLOCK OPTIONS** - NOTE: DROM kits require V2.0 software which is included with the kit or can be purchased separately. These kits are 8 megabytes of additional samples that permanently reside in internal memory. Either or both may be installed in your K2000/K2000R, increasing the ROM up to 16 or 24 megabytes.
- **DRMB-K DAUGHTER BOARD KIT**, which holds either or both of the DROM upgrades, must be installed in order to accommodate these sound blocks.
- **DP-RAM PROGRAM RAM OPTION** - Changes the amount of battery backed Program RAM from 116K to 760K and allows up to 1,000 programs/setup/songs to be stored. This option requires V1.28, V1.29 or V1.30 software. (Note: this option is not to be confused with SIMMs memory, which is for loading of samples only.)

*Installation of any of the above Options without the DFK-1 Fan Kit may damage the K2000/K2000R and/or the Options...AND may also void all warranties.*

## **ACCESSORIES**

- **DFS-1** Footswitch (for Sustain, Sostenuto, or any switch function)
- **DCC-1** Continuous Control Pedal (for Volume Change, Filter Sweeps, etc.)
- **DSBC** Soft Bag Case for transporting the K2000
- **DHSC** Hard Shell Case for transporting the K2000, non-ATA approved

## **KURZWEIL K2000 VIDEOS**

- **DYCA-12** K2000 Intermediate Programming Tutorial Video
- **DYCA-13** K2000 Advanced Programming Tutorial Video
- **DYCA-14** K2000 Sampling Tips and Techniques Video

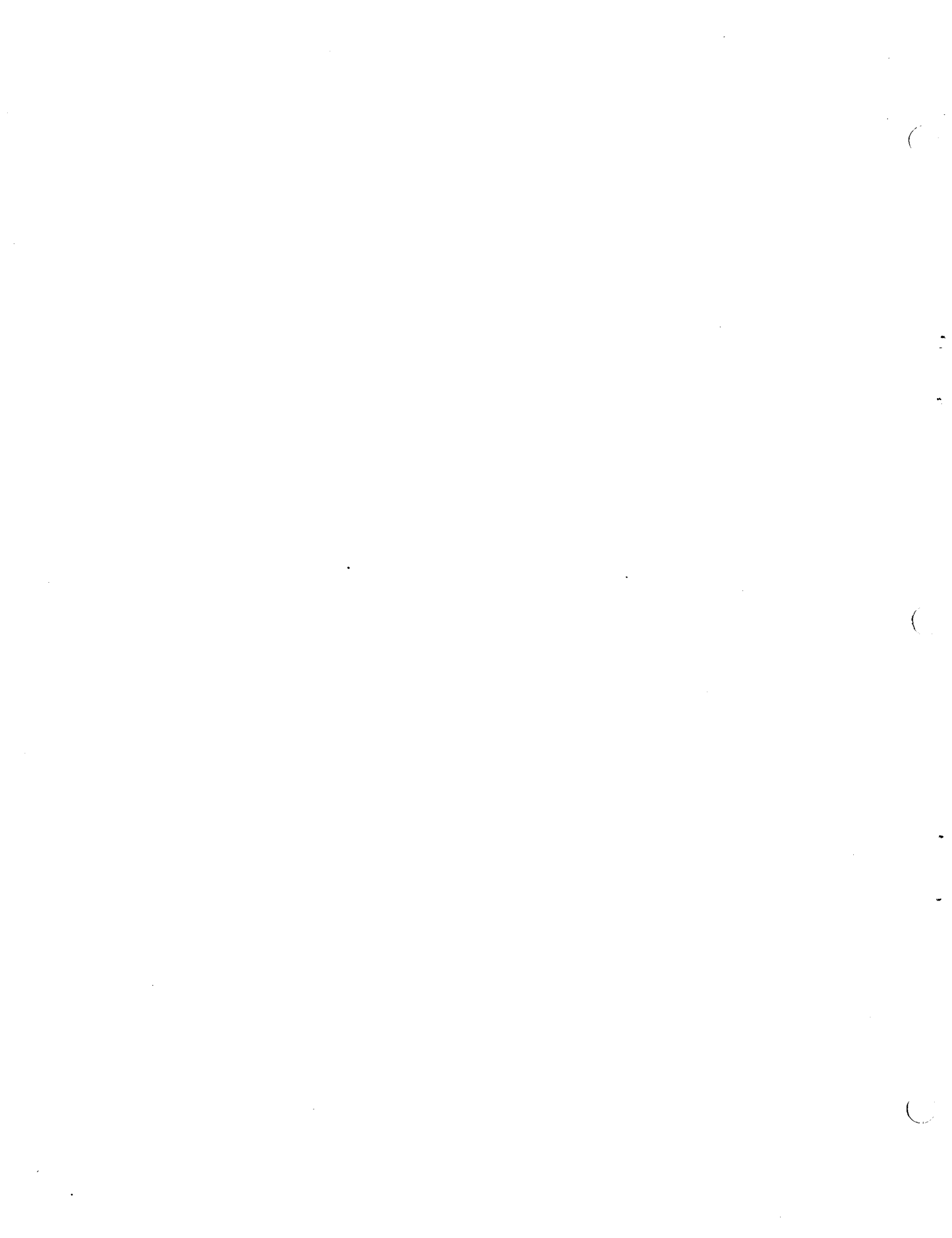

## 5.1 K2000 AUDIO/POWER BOARD THEORY

## SCHEMATIC PAGE 1

## 5.1.1.1 SCANNER MICROPROCESSOR

Note: Refer to Block Diagram (Figure 5.1.6.1 on page 15 for assistance.

The M37450 integrated microcomputer (U30, E-3 to E-6) on page 1 of the Audio/Power Board schematic contains 16K of ROM, 384 bytes of RAM, 8 A/D input lines, 2 D/A output lines and 6 ports of I/O. It is responsible for scanning the keyboard, panel buttons and performance controls. It also controls the panel LEDs, LCD contrast, and variable-gain amplifiers and audio routing switches. It communicates bi-directionally with the Engine microprocessor over a 31.25Kbaud serial link.

The M37450 is RESET by the same signal as the Engine Board and the Effects Processor which enables simultaneous starting. The 10MHz clock for the M37450 is delivered from the Engine via J7 (A-5).

The analog I/O section will address 8 analog inputs and two analog outputs. It contains only one 8-bit A/D converter and internal circuitry to select which of the 8 inputs is addressed at any given time. There are two separate latched 8-bit D/A converters. There are separate reference voltages for the A/D and D/A converters. These are connected to +5Vref. The M37450's digital circuitry is connected +5Vdig.

It is important to note that during power-up the +5Vref rises faster than +5Vdig which can cause the M37450 to "latch up" and overheat. D2 (D-6) prevents this by keeping +5Vref from being more than 0.6 volts more positive than +5Vdig during power-up.

## 5.1.1.2 MUSIC KEYBOARD INTERFACE

The music keyboard has two PC boards with the keyswitches on them and a cable from each. Each board has an 8 column by 8 row keyswitch matrix which covers 32 keys with two switches per key. Connected together, the matrix is 8 columns by 16 rows. Because there are 61 keys on the keyboard, only 58 of the 64 positions on the treble circuit board are connected.

The matrix, part of which is diagrammed below, is connected such that the 8 columns are driven by Port 2 and the 16 rows are sensed by Ports 0 and 1. During operation, the column being driven is low and the remaining 7 columns are high. Pull-up resistors in RP7 and RP8 hold all of the rows high. If a switch contact is closed, it will pull the row to which it is connected low. Keyswitch isolation is accomplished by the diodes in series with each key contact. The M37450 drives each column in sequence, then reads the rows on Ports 0 and 1. This scan sequence is repeated every 250uS and the resulting keyboard image (status) is stored in internal RAM. The high scanning speed is necessary to resolve minute variations in keyboard velocity for expression.

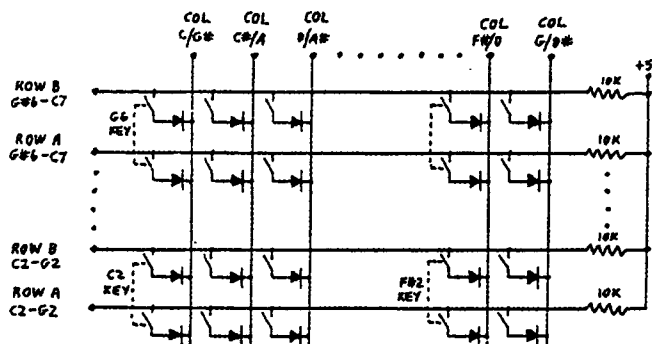

Figure 5.1.1.1 - Portion of keyswitch matrix

Because the keyboard is large, the printed circuit wiring is extensive, and the boards do not have a groundplane, there is potential for the keyboard to radiate RFI from the constant scanning. R-C filters are used on all keyboard lines to "soften" the waveform edges and suppress RFI from the clocks. Resistor networks RP1-RP6 are 100 ohm series resistors and 24 individual 100pf capacitors are used on the scanning lines.

## 5.1.1.3 DEBUG PORT

J3 (I-5 to I-6), which is the connector for the bass portion of the music keyboard, is a 26-pin header, although only a 16-pin header is installed for normal operation. With a 26-pin header installed, it and J2 (I-3 to I-4) become a debug port. When JP1 (E-7) is open-circuited (a thin trace on the solder side must be cut), the M37450 begins operation in "microprocessor mode" in which case Ports 0 and 1 become an address bus and Port 2 becomes a data bus. The extra 10 pins on J3 carry the remaining signals needed, including power, to interface to a "debug pod" which



contains EPROM (to hold a monitor program), RAM (to hold the program being debugged), serial port logic to talk with the development host, and logic to recreate ports 0 - 2.

NOTE: This port is normally only used at depot level service. Do not attempt to use this port for debugging unless specifically instructed. The purpose for this discussion was to define the reason for the extra pins at J3 and the need for JP1 to be intact for normal operation.

#### 5.1.1.4 FRONT PANEL INTERFACE

The K2000 front panel consists of 38 pushbuttons, 8 LEDs, and a continuous rotation "spin knob". The buttons are wired into a 10 column by 4 row matrix. U31 (B-4 to B-5), receiving 4-bit binary information from the M37450 drives one column at a time low. The 4 rows are held high by pull-up resistors in RP9 (E-2). If a button is pressed, the appropriate row is pulled low and sensed by the M37450. Because there are no isolation diodes for the front panel, the number of simultaneous button closures that can be sensed is limited to 2 unless they are all in the same row or column.

The LEDs are wired in an 8 column by 1 row matrix, driven by a transistor current booster Q1 (B-4). To turn an LED on, the M37450 will activate Q1 by driving Port 6, bit 7 high when the column connected to the LED is selected. Q1 is normally off when the M37450 is actually sensing buttons in order to minimize the saturation voltage of U31 and give a good logic low level to sense. Q1 is an emitter-follower which minimizes current drawn from the M37450. R81 suppresses possible emitter-follower oscillations.

The spin knob is a rotary switch with 2 contacts, 36 positions, and continuous rotation. Each contact is either open or connected to GND2. The switching sequence (Gray code) is such that the M37450 program can detect which direction the switch is being rotated and how many positions. One property of this code is that if the two contacts connections are reversed, the direction of rotation will interpreted as reversed by the M37450.

U60 (C-5) is used to interrupt the Engine microprocessor by activating EXTIRQb at pin 6. This is accomplished by taking column C high while column D is already high. The Engine acknowledges this, and resets U60, by sending EXTIACKb to pin 1 of the flip-flop.

#### 5.1.1.5 WHEELS INTERFACE

The wheels are standard rotary potentiometers actuated by large "thumbwheel" knobs. Only 1/3 of the allowable rotation is used, thus the mechanical center must correspond fairly close to the electrical center of the pots. Amplifiers U59-7 and U59-8 provide the necessary gain so that 1/3 rotation results in a full 0 to 5 volt swing for the M37450's A/D inputs. C194 and C191 filter noise and smooth the output. R149, R150, D5 and D6 prevent overload of the M37450 A/D inputs in the event of gross wheel mis-adjustment.

The Wheels circuit board itself contains a network for each wheel which allows electrical adjustment of the centering and exact amount of amplifier gain. Figure 5.1.1.2 below is the schematic for one wheel; both circuits are identical. The circuit board's pots are adjusted to match the characteristics of each particular wheel's pot.

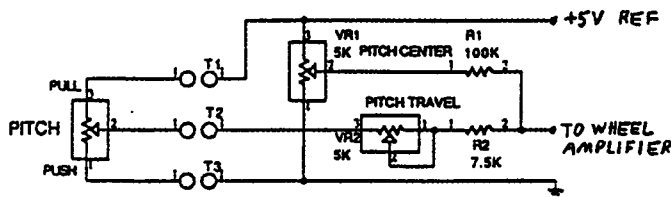

Figure 5.1.1.2 - Wheel adjustment circuit

#### 5.1.1.6 PRESSURE SENSOR INTERFACE

The keyboard pressure sensor is a long strip between the keys and the keybed. When pressure greater than that needed to hold a key down is applied, the strip is compressed and changes from an open circuit to a resistance that varies with the amount of pressure.

R206 and D19 together make a 0.6 volt source with just a few ohms of dynamic impedance resulting in a reasonably linear current/pressure curve. This voltage is applied to the pressure strip through J5-6. (A-2) The resulting current flow ranging from 0 to about 1.0mA returns through J5-7 and is converted to a voltage by U59-1 (C-2). R209 adjusts sensitivity and C159 filters out noise. R147 and D4 prevent overvoltage, (from overpressure) from affecting the A/D inputs of the M37450. D4 (D-2, Schottky diode) clamps any overvoltage to no more than 0.3 volts above the A/D supply voltage.

**5.1.1.7 PEDALS INTERFACES**

J19 (A-1) receives variable inputs from a "control" pedal and can be used to control timbre, pitch, etc. The circuit is optimized for a 10K linear taper potentiometer in the pedal, but will work with higher resistances. Alternatively a control voltage of 0 to +5 volts can be input directly to J19 to produce the same effect. For use with a pot type pedal, R197 and R199 (B-1) supply a current-limited reference voltage to the pedal. This voltage is equal to the +5ref when the pot's resistance is 10K; thus there is no voltage drop across the limiting resistance. Limiting resistance is necessary to prevent circuit damage or malfunction is a mono plug is inserted into J19.

R195 pulls the pedal voltage input to zero when there is no plug in J19. R196 and D18 (C-1) protect the A/D converter from overvoltage and C184 filters out noise.

J16 (I-1) and J17 (I-2) receive footswitch plugs and look for switch closures to ground. RP7-10 (G-2) and RP8-10 (F-2) are pull-up resistors and keep the M37450 inputs high when no pedals are plugged in or the pedal contacts are open. RFI suppression is accomplished in the circuits of R188, R189, C180 and C181 (H-1 to H-2). At power-up, the M37450 looks at the status of J16 and J17 and assumes that state to be "OFF"; the opposite state being "ON". This allows for use with NO or NC pedal switches.

**5.1.1.8 LCD Vee VOLTAGE GENERATOR**

The LCD on the front panel requires an adjustable negative voltage source to control the contrast. This voltage must not be applied until after the LCD has been initialized. The LCD Vee circuit (F-7 to H-7) performs these functions.

The pulse-width modulated output from the M37450 is used as a third D/A output to control the Vee voltage. When filtered by R146 and C196, the duty cycle of the PWM waveform is converted into a voltage between 0 and +5 volts. U59-14 converts this to a -12V to +12V swing. Note that the center voltage from the Wheels Interface (+2.5V) is needed to do this properly. If the Wheels Interface is not plugged in, the LCD contrast will be wrong. D20 and R154 prevent the Vee voltage reaching the LCD from exceeding +5 volts. Vee will be affected by changes in the +5 volt digital supply. If it varies by more than 0.1 volt high or low, the LCD contrast adjustment range may not suffice to compensate.

Q20 and R152 are connected so that the Vee voltage is forced to the positive rail when RESET is active, thus ensuring the display is inoperative when the processors are not running. Approximately one second after RESET goes inactive, software will set a default level for Vee, about -8.5 volts. This voltage may be changed by a message from the Engine Board to set to a user stored value, if so programmed.

**5.1.1.9 AUDIO PATH CONTROL OUTPUTS**

The audio path requires 6 digital signals to control switches and 2 analog signals to control variable gain amplifiers. The digital signals are noise-isolated from the analog circuitry by R79-80 and R136-139 (F-6).

**5.1.1.10 OPTION CONNECTOR**

The 8-pin option connector (E-1) is included to utilize unused resources of the M37450 and to provide for additional user control features in the future. Power (+12 and +5 volts), two analog inputs, and one digital I/O line are provided.

## 5.1.2 K2000 AUDIO/POWER BOARD THEORY

## SCHEMATIC PAGE 2

## 5.1.2.1 POWER SUPPLY

Refer to K2061 AUDIO/POWER BOARD schematic, page 2 of 6, for details.

The rear panel and bottom shield are used as a heatsink for the five TO-220 packaged power semiconductors. For testing in unrestricted free air, just the rear panel is acceptable as a "short-term" heatsink although it will get hot to the touch. **NOTE: TESTING WITHOUT A HEATSINK IS NOT ALLOWED AND WILL RESULT IN SHUTDOWN OR DESTRUCTION OF SOME OF THE POWER SEMICONDUCTORS IN A MATTER OF SECONDS.** The surfaces between the shield plate and the rear panel should be coated with white thermal heatsink compound for improved heat dissipation.

The rear panel is at analog/chassis ground potential; thus all power semiconductors must use an insulated mounting. The sketch below (figure 5.1.2.1) details the mounting hardware necessary to accomplish this. When installing this hardware it is critical that the semiconductor mounting hole be aligned with the panel mounting hole. If they are not and the screw is forced in, the screw threads will cut through the wall of the shoulder washer and short-circuit against the semiconductor's mounting tab.

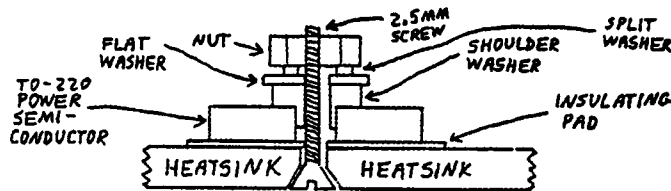

Figure 5.1.2.1 - Heatsink mounting detail

## 5.1.2.2 EXTERNAL TRANSFORMER

A separate power transformer converts selected line voltages to 100, 115, or 230 volts. It contains two center-tapped secondaries, 12 and 28 volts. Low voltage AC enters through J20 (A-1). All voltages in this section will be given for the 115 volt configuration. Figure 5.1.2.2 below details the external transformer connections.

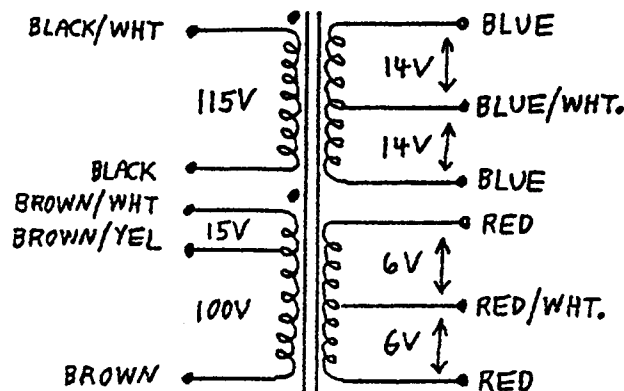

Figure 5.1.2.2 - Power transformer wiring

## 5.1.2.3 RECTIFIERS AND FILTERS

D23, D24 (B-1) and C192 (C-1) provide unregulated +20VDC to TP25 (C-1) from which +12Vana, +5Vana, +5Vref and +8VDC are derived. D21, D22 (B-1) and C190 (C-1) deliver unregulated -20VDC to TP22 (C-1) to provide -12Vana, -5Vana and -15Vbias. C192 is larger than C190 because of the potentially greater load from the optional hard disk on the positive supply. C197 and C198 prevent low frequency RF rectifier switching noise from feeding back through the line cord.

**NOTE: No secondary fuses are provided. Primary fuse in power entry module protects sufficiently against current overloads.**

**5.1.2.4 ANALOG REGULATORS**

VR5, C186 (F-1) provide +5Vana and VR2, C188 (G-1) provide +5Vref; both circuits are sourced by VR7, C207 (+12Vana @ TP23, D-1 & E-1).

VR3, C193 (D-1) provide +12VDC for the optional hard disk at TP19 (H-1) and pin 1 of J18 (I-1). R200 is required to lightly load VR3 when the hard disk is not installed; this prevents oscillation.

VR6, C206 (D-2) provide -12VDC for the audio circuitry at TP24 (E-2) and becomes -12Vana.

VR5 and VR4 provide quiet +5 and -5 volt power to the analog switches in the audio path. VR2 provides an isolated and quiet +5 volt reference to the A/D and D/A converters on the scanner microprocessor and sever performance controls.

VR1, C182 (D-2) outputs -15Vbias for the LCD Vee generator and muting circuit. This regulator may cease regulating at low line voltage, however the only effects are a possible reduction in LCD contrast and premature clipping of large negative signal peaks.

**5.1.2.5 DIGITAL REGULATORS**

The circuit of D25 (dual Shottky, B-2) and C202 (B-3) provide high current availability of +8VDC (unregulated) @ TP17 (C-2). This current source is used by the digital regulator circuit(s). Due to the lower forward voltage drop of a Shottky rectifier, less heat is dissipated by the rectifier and the transformer voltage can be lower; however because of the heavy current drain on the +5 volt supply (up to 3.5 amps), it is necessary to heatsink D25 to the rear panel. C200 and C201 suppress rectifier switching noise.

The circuit of U62 (C-3) and Q18 (E-3, a VMOS power FET) makes an ideal pass transistor for a linear regulator and provides +5VDC for all digital circuitry at the output end of L5 (I-2). This circuit is wired as a voltage follower, thus the final output voltage at the source of Q18 is forced (by the gain of the op-amp, U62) to equal the reference voltage at its non-inverting input. This voltage can be monitored at TP16 (H-2). The output is adjusted at R180 for exactly 5.00 volts (C-4) to optimize performance of the custom VLSI chips on the Engine Board.

It is extremely important for the Engine board to know when there is sufficient voltage for proper operation so as to reset itself. The mute circuit(s) must also be asserted when there is insufficient voltage. Simply put, when the output of U62 is within 1.2 volts of its supply (close to its saturation point), Q16 and Q17 cut off saturating Q15 and discharging C176 quickly. The reset circuit (described later) immediately asserts RESET to all microprocessors and mute circuit(s).

R192 and C174 stabilize the feedback loop to prevent oscillation of the regulator. C178 and C180 improve regulation during sudden load changes. R193 provides a minimum load if the power supply is ever operated with no other components on the board.

**5.1.2.6 BACKUP VOLTAGE SUPPLY**

Three AA alkaline cells provide power to three RAM chips during power off. Standard alkaline cells are used instead of the more expensive lithium cells because power drain is approximately the same; thus reducing cost to the customer.

When power is off, current from the battery passes through R182 and D16 (I-3) to the BUVdd line which is connected to the power pins of the 3 RAM chips (one on the Audio/Power Board and the remaining two on the Engine Board). D17 prevents battery power from backing into unwanted circuitry.

With power up, Q19 provides power to the RAM chips. D17 ensures gradual application of full voltage to the RAMs during power-up. C203 (E-7) provides 30 - 60 seconds of RAM power to allow for battery change when needed.

**5.1.2.7 LCD BACKLIGHT POWER SUPPLY**

The backlight for the LCD requires approximately 100 volts rms, at approximately 360Hz operation. The circuit of Q25 and T1 (G-4 to H-5) fulfill this need. The backlight cable must be plugged into J21 (I-5) for Q25 to oscillate. A reasonably good sine wave appears at J21-4. C208 and R218 provide the positive feedback route.

Q24 and surrounding circuitry provide a controlled higher voltage from the unregulated +8 volts so as to improve LCD brightness. The output voltage can be adjusted to balance between brightness and the acoustic noise level from the panel by changing the value of R216 (F-5).

## SECTION 5

AUDPWR2.DOC 12/15/92

### 5.1.2.8 RESET CIRCUIT

The reset circuit provides a power-up delay between sufficient power for operation and release of the RESET signal to the microprocessors. Also, at power-down (or severe line voltage dip), this circuit re-asserts RESET when the +5VDCdig regulator drops out of regulation. The reset circuit consists primarily of U61 (H-3). It is wired as a high impedance schmidt trigger and gives a fast rise and fall time signal to the microprocessors. Feedback through R156 (H-3) latches the circuit in either the high or low state. Current through R155 overrides the feedback current and forces the latch to flip. The last stage (U61-8) enables both active-high RESET and active-low RESETb.

**5.1.3 K2000 AUDIO/POWER BOARD THEORY SCHEMATIC PAGE 3****5.1.3.1 AUDIO SECTION**

The audio section, less effects, is on schematic page 3. This covers D/A conversion, filtering, switching, mixing, and amplifying circuitry that handles the "dry" audio signals.

**5.1.3.2 D/A CONVERTERS**

U37 and U39 (B-1 to B-4) are each dual 18-bit D/A converters with serial data inputs. There is thus one D/A converter for each audio channel. Although the Hobbes chips on the Engine Board are capable of multiplexing one DAC among 2 or 4 channels, the one output per DAC mode was used on the K2000 to minimize noise and distortion.

The AD1864 is a dual DAC with separate serial inputs, separate Latch Enable pins, and a common clock pin. The Hobbes chip on the Engine Board was designed so that the sequence and timing of the DAC signals would be directly compatible with the AD1864 and all other serial input DACs claiming "PCMS6 compatibility". The serial bit input rate is 9.968MHz and the word input rate is actually 96.000KHz. This is not the same as "2X oversampling" because each pair of very slightly different words is derived from the same sample but it does significantly reduce distortion of very low level signals. Either current or voltage output connections can be used. Here the DACs are wired for voltage output which is fixed by the chip design at +/-3 volts full-scale. Note that only the Engine Fake board or specially programmed sounds ever approach this high amplitude level; normal keyboard playing produces amplitudes in the 0.1 to .05 volt range.

For minimum digital noise feedthru, the power and ground wiring of the AD1864 is very critical. The digital section of the chip requires + and -5 volts and has its own ground as does the analog section. +5ana and -5ana power the analog section directly and the analog section ground is tied to analog ground. +5ana and -5ana also go through RF chokes L1 and L2 (B-5) and filter capacitors C128, C169, C130, C172 (A-2 to A-4) and power the digital section. The chokes and capacitors prevent digital activity in the chip from feeding back into the analog power supplies. Ground for the digital section is connected to digital ground. In the layout, the digital groundplane is under the chip's digital pins while the analog groundplane is under the remainder of the chip.

U38, U40 and surrounding components (E-1 to E-4) amplify the +/-3 volt full-scale signals from the D/A converters to just over +/- 6 volts to optimize the signal-to-noise ratio through the following filters. They also provide a small boost at very high frequencies between 15KHz and 20KHz to counteract a slight droop in the downstream filters. Sampling theory is valid only for signals reconstructed as impulses. When reconstructed as stair-steps, the high frequencies near 1/2 the sampling rate are rolled off by as much as 4dB. At 20KHz in a 48KS/s system, the loss is about 2.8dB. Although the U38 and U40 circuits are low-pass filters with a cutoff of about 25KHz, their "Q" is high which gives a boost to the frequencies just below cutoff. Note that incorrect values for the resistors and capacitors could easily cause a very distorted frequency response curve or even oscillation.

**5.1.3.3 LOW-PASS FILTERS**

F11-F14 (F-1 to F-4) are passive, L-C type, low-pass filters that remove high alias frequencies from the D/A converted signals. With the source and load properly matched, the loss through the filters is slightly more than 1/2 (6dB) which brings the +/-6 volt boosted signal from the DACs back to just under +/-3 volts.

Although the filters are efficient and have a very sharp cutoff, they are vulnerable to AC magnetic fields because of the coils. In order to minimize audible hum, they must be kept away from the power transformer and the low-voltage wiring between the transformer and J20 which also produces a magnetic field because of the large currents flowing. In the K2000 case, the power transformer must also be oriented such that the filters are in a "null point" of the transformer's flux field. In addition, they could even pick up hum from another piece of equipment, such as a power amplifier or another instrument, placed immediately below or above the K2000 case. TAKE CARE TO PREVENT THIS.

**5.1.3.4 SEPARATE OUTPUT AMPLIFIERS**

U34 and U35 (H-1 to H-4) amplify the +/-3 volt signals coming from the low-pass filters to +/-6 volts. They also provide sufficient power to drive the 4 separate output jacks and loads as low as 600 ohms. R163 and R168-170 provide a source impedance to the jacks of 600 ohms, isolate the amplifiers from capacitive loads (like long cables), and are also part of the RFI suppression network along with C167, C170, C171, and C177.

5.1.3.5 MUTING CIRCUITS

During power-up and power-down, muting circuits on all audio outputs are asserted to prevent transient noises and damage to speakers and human ears. The muting circuit description provided here applies to all other outputs as well.

Using the Q11 circuitry as an example (I-1), this J109 N-channel JFET is either ON or OFF. When OFF, it is not conducting, thus any audio present passes through R163 and out J11. When ON this JFET shorts the output line to ground, thus muting the circuit. To control this function take note -UNMUTE arriving in the upper left corner of the schematic (A-1), being delivered from the collector of Q23 (H-7) on schematic page 2. This signal, when high, cuts off Q11, and all other JFETs so connected and allows the passage of audio. When low, the JFETs are ON and the mutes are asserted.

5.1.3.6 AUDIO SWITCHING MATRIX

The scanner microprocessor has direct, individual control over the 6 analog switches and pairwise control of the 4 variable gain amplifiers. Five of the analog switches (ASW\_1, ASW\_3 - ASW\_6) are in audio signal paths while the sixth is in a gain control signal path (ASW\_2).

Note: ASW\_1 and ASW\_2 audio switching controls are drawn on schematic page 4. Refer to figure 5.1.3.1 below for a simplified detail of the Audio Switching Matrix.

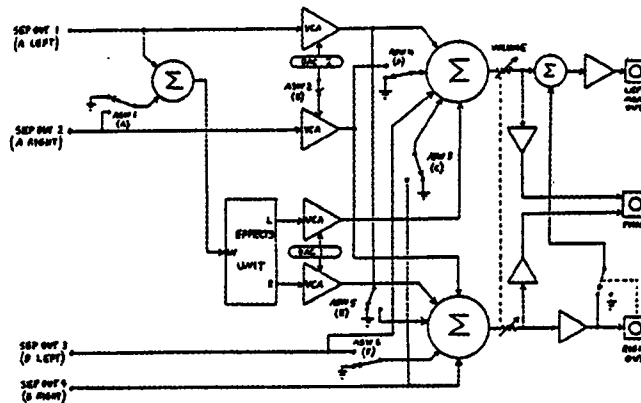

Figure 5.1.3.1 - Audio switching matrix

In all of the audio path switching cases, the switch is connected to the summing junction of a non-inverting op-amp with the input resistor at the input of the switch. Signal current through the input resistor either enters the summing junction when the switch is on or is diverted to ground when the switch is off. This makes each switch a current-mode switch which allows it to block large voltages when off and avoid large voltage swings when on. This minimizes distortion of the signal and crosstalk. It also allows the switch to handle signal voltages greater than its own power voltage. A simple detail of the Analog Switch follows in figure 5.1.3.2.

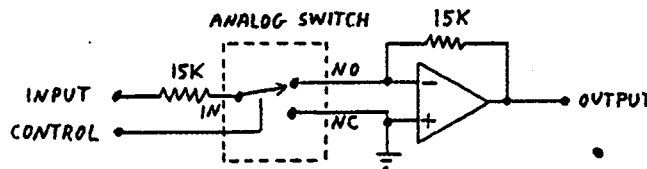

Figure 5.1.3.2 - Analog switch connection for audio signals

Note that the IN and NC terminals are connected when the control voltage is low (switch off). IN and NO are connected when the control voltage is high (switch on).

5.1.3.7 MIX OUTPUT AMPLIFIERS

The two sections of U1 (C-6 to C-7) do the final mixing of audio signals from the switching matrix and Effects Unit. Each sums 5 signals from various sources into one. A low noise amplifier is used here because the "noise gain" of the circuit is 5 even though the effective gain for any one signal is unity. The 100pF capacitors across the feedback resistors compensate for stray capacitance at the large summing junction and also the finite load capacitance presented by the cable to the volume slider. The signal level going into the volume slider is 6 volts peak if one of the mixed sources should reach peaks near 6 volts simultaneously.

The return signal from the volume slider varies from 0% to 100% of the signal driven to the slider by U1. The final mix output amplifier for the Right Channel is U33-1 (G-6) which simply inverts the slider's signal at unity gain. If no plug is inserted into the Right mix output jack (J10, I-6), the Right output signal is also sent to the Left output amplifier to be mixed with the Left signal from the volume slider. This provides automatic mono output through the Left output jack when no Right channel cable is used. Note the Right signal must be mixed without inversion into the Left output amplifier to keep phasing correct in the mono signal. The 600 ohm source impedance and muting arrangement for the mix outputs is the same as for the separate outputs described elsewhere.

#### 5.1.3.8 HEADPHONE AMPLIFIERS

To drive the headphones adequately, a non-inverting gain of 2 amplifier with a power booster stage is used. Using the Left channel as an example, op-amp U5-1 (F-6) provides the voltage gain and Q2-Q3 provide current gain to drive low-impedance headphones. R91, between the bases and emitters, allows the op-amp to drive the load directly for currents less than 6mA peaks and eliminates crossover distortion. R160 (H-7) protects the transistors from user overload caused by a short-circuited cable or driving a too great load.

It is possible for the headphone amplifier to clip at high volume slider settings. This occurs at about 10 volts peak for typical headphone loads and would normally be extremely loud. This clipping will not affect any other audio outputs.

Muting of the headphones is accomplished by Q4 and Q7 (F-6) by shorting the op-amp's (U5) outputs. If the Audio/Power Board is operated with a signal but the mute is activated for an extended time (such as on the test bench), U5 will become quite warm, but will not be damaged.



## 5.1.4 K2000 AUDIO/POWER BOARD THEORY

## SCHEMATIC PAGE 4

## 5.1.4.1 VOLTAGE CONTROLLED AMPLIFIERS

Four voltage controlled amplifiers are also part of the audio switching matrix plus they allow adjustment of the ratio of unchanged "dry" signal to altered "wet" signal from the Effect Unit. The SSM-2122 amplifiers used are duals but each half has independent input, output, and control terminals while the bias current terminal is common.

U9-14 (E-3), which controls the gain between SEPOUT\_2 and OUT2\_MOD, will be used for discussion. The amplifier is a current-in/current-out device in which the current gain is varied by a control voltage. For low frequencies, R108 ((B-2) converts the SEPOUT\_2 signal into a current which is fed into U9-10. Its value of 15K converts a maximum signal peak of 6 volts to a current peak of 400uA. When U9 is set for unity gain, its output current will be the same as its input current, namely 400uA. This current, fed into the summing junction of op-amp U36 (F-3), will be converted back to 6 volts by virtue of its 15K feedback resistor.

At frequencies greater than approximately 2KHz, R107 and C111 begin to boost the input current for a given input voltage while R124 and C124 supply an exactly opposite cut in output voltage for a given current. This boost/cut, which reaches a maximum of nearly 12dB at 20KHz, reduces the apparent random background noise level of the SSM-2122 by about 10dB. The SSM-2122 will clip at input/output currents greater than 500uA peak, which is twice the bias current through R68 (F-4), so the maximum signal at high frequencies is limited. Under virtually all normal conditions an audio signal carries substantially less energy at high frequencies than at low frequencies, thus making this nearly impossible. R51 and C35 (E-3) prevent the SSM-2122 from oscillating. Because the SSM-2122's input impedance is very low, they have minimal effect on the high frequency response.

For gain control, the SSM-2122 has differential voltage inputs, +CTL and -CTL. When they are at equal voltage levels, gain is unity. As the + input becomes more negative than the - input, gain reduces on a logarithmic scale at the rate of .005V/dB. The 6.5:1 voltage divider formed by R106 and R103 make this .039V/dB which for a 5 volt control range translates into 128dB of control range. The control voltage ultimately comes from an 8-bit D/A converter in the scanner microprocessor, the control sensitivity becomes 1/2dB per bit. R57 (E-3) is needed to balance the control voltage inputs.

For the U0-14 example, the control voltage is switched by an analog switch. This allows that particular amplifier to be set to unity gain while the other amplifier (U9-2, E-4), driven from the same control voltage, continues to be controlled. Unlike the audio path switches, this control path switch is operated in the voltage switching mode which is OK because any non-linearity won't cause waveform distortion.

Control voltage buffers, U32-1 (B-6) and U32-7 (B-4) allow the relatively weak D/A converter outputs from the M37450 to drive the approximately 600 ohm load presented by two SSM-2122 control voltage inputs. R86, R92, C106, and C107 (B-4) smooth sudden changes in the control voltage level to provide smooth, clickless changes in gain.

## 5.1.4.2 EFFECTS MIXER

The Effects Mixer is shown on the top section of schematic page 4. U6-7 (E-1) is the actual mixer stage which combines SEPOUT\_1 and optionally SEPOUT\_2 into a mono signal for the effects processor. Analog switch U2 (C-1) determines whether current from the SEPOUT\_2 signal enters the mixer stage or is diverted to ground. Because the reverb circuit is noisy and also because the A/D/A conversion process does not have a very flat frequency response, two poles of high frequency boost are added across the input resistors R3 (B-1) and R43 (E-1). The gain of this stage is unity from wither input signal at low frequencies. The effects A/D converter clips at +/-8 volts leaving some headroom for both inputs to approach their 6 volt maximum.

## 5.1.4.3 EFFECTS INPUT LOW-PASS FILTER

The input anti-alias lo-pass filter is split between schematic pages 4 (F-1 to G-2) and 5 (A-5 to B-6). The complete filter consists of two cascaded 3-pole Butterworth sections with component values again scaled from the DSP-256 values to account for the 32MHz clock. Although quite different from the L-C filter described elsewhere, this circuit was selected to avoid altering the desirable "DSP-256 sound".

## 5.1.5 K2000 AUDIO/POWER BOARD THEORY

## SCHEMATIC PAGE 5

## 5.1.5.1 EFFECTS SECTION

The Effects Section is mono-in, stereo-out and can perform reverberation, echo, delay, frequency equalization, chorusing, and flanging. Although the processing happens digitally, the input and output data format is not compatible with the KISS format produced by the Engine Board; thus it is necessary to convert the analog audio signal to be processed into digital form, have the effects section process it, and convert it back into analog audio. The Effects Section could be removed with little or no effect on the remaining circuitry.

Virtually all of the effects circuitry is licensed from DOD Digitech and is basically contained in the DSP-256 stand-alone effects processor. One significant difference from the DSP-256 standard is the clock frequency has been reduced from 36MHz to 32MHz which is available from the Engine Board.

An official circuit and software description from DOD is not available, thus the following discussion represents Kurzweil engineering's analysis.

The Effects Mixer and Effects Input Low-Pass Filter circuits are described in 9.4.2 and 9.4.3 connected with schematic page 4.

## 5.1.5.2 EFFECTS A/D CONVERTER

The single channel of A/D conversion and two channels of D/A conversion needed would normally require one A/D converter and two D/A converter chips. However in the DOD circuit, one 16-bit parallel input D/A converter, U16 (G-3 to G-4), is time-shared among the three functions. Analog switches in U10 and U14 (C-5 to C-7) do the switching among the three functions of U16. The S&HL and S&HR (Sample and Hold left and right) signals from the Effects LSI chip (U50, C-1 to D-4) processed through U49, control these switches. Although each switch IC has 3 sections and only 3 switches are needed in all, the A/D function switch (U10) was separated from the D/A function switches (U14) to reduce crosstalk and the resulting distortion. Refer to figure 6 in 9.3.6 (for schematic page 3) for simplified details on the analog switch operation.

The "A" switch section of U10 along with op-amp U12-7 (D-5) and C43 (D-6) perform as a sample-and-hold circuit which holds the signal voltage stable while the A/D conversion is taking place. Placing an oscilloscope probe at TP1 will show a sampled version (stair-step approximation) of the input signal. Voltages higher than 8.0 volts peak at this point will be clipped by the A/D converter.

U50 performs A/D conversion by sending trial values to U16 which converts them into analog currents which are converted into voltages by op-amp U13. comparator U11 then tells U50 whether the trial value is less than or more than the analog input signal at TP1. Based on that result, U50 sends out another trial value. Sixteen trials are performed to determine the signal voltage to an accuracy of one part in 65,000 and the whole process requires 24 microseconds (1.5uS/trial).

There are three adjustments around U16 which are required for quiet, distortion-free performance. R63 (H-4) adjusts the linearity of U16 by slightly changing the most significant bit value. It is typically adjusted to minimize visible distortion of a 20mv sine wave. R122 (G-3) adjusts the DC offset and is normally set for +50mv at TP6 with no signal to minimize residual distortion of small signal amplitudes. R69 (G-3) adjusts the full scale signal level and is normally set for 8 volts full scale at TP6.

Throughout the Audio/Power Board, Digital Ground (Dgnd) and Analog Ground (Agnd) are kept separate. Since U16 has a single ground pin for both its analog and digital section, the two ground systems are connected together under U16. This connection is called GJ1 in the schematic and is actually two pads under U16 with a trace connected across them on the solder side of the board. Plugging in the optional hard disk drive may also connect the two ground systems together at J18 because most hard drives tie the +12 Return and +5 Return pins together at the drive's power connector. Typical DC power cables however should have sufficient impedance to prevent serious groundloop problems. If not, it might be necessary to insert a choke in series with the +12 return lead from the hard disk drive.

## 5.1.5.3 EFFECTS D/A CONVERSION AND FILTERING

Two analog switch sections of U14 are used for the two channels of D/A output. One at a time is turned on by signals from U50 through U49 and the corresponding voltage from U16 and U13 is held on capacitors C45 and C48. The held voltage then appears in low impedance form at U15-1 (D-5 to D-7). As with the sampled input voltage, these two points should show stair-stepped approximations of the processed output signals.

U50 cannot provide settling time for smooth transition between new data being presented to U16 and the output analog switch closures to begin passing the converted voltage to the output. The

two flip-flops in U49 (A-7) serve to delay the control signals from U50 to the analog switches sufficiently to allow for smoother transition from previous value to settling transient to new value in a more linear fashion and eliminate distortion at low signal levels.

After conversion to sampled analog voltages at U15-1 and U15-7 (D-6 to D-7), the effected audio signals are filtered by circuitry around U7 (F-6 to G-7). Each filter is two cascaded 3-pole Butterworth sections identical to the input filter described elsewhere.

After filtering, the audio signals go through voltage-controlled amplifiers at the bottom of schematic page 4. In order to get the phasing correct with respect to the "dry" signal that bypasses the Effects Unit, two inverting amplifiers are required in each channel. The first performs current-to-voltage conversion while the second reinverts the signal's phase and applies one pole of the high frequency cut to cancel the lower boost pole added at the input mixer. The high-frequency droop in the A/D/A process.

#### 5.1.5.4 EFFECTS LSI CHIP AND DELAY RAM

The Effects LSI chip (U50) is the largest IC on the Audio/Power Board. It is an 84-pin surface-mount chip under the RFI shield along with the other digital circuitry. It has three basic interface ports.

The MCA (MicroCode Address) and MCD (MicroCode Data) busses form the MicroCode Port which is how the chip receives instructions for performing any given effects algorithm. Every 125nS a new microcode address is sent out on the MCA bus and somewhat later the corresponding microcode data is received from the MCD bus.

The Analog I/O Port consists of the DAC bus and control signals MSREG, LSREG, S&HL, and S&HR. Sixteen bit values destined for the D/A converter are output 8 bits at a time on the DAC bus and then latched into U17 (E-3) and U18 (E-4) under control of MSREG and LSREG. S&HL and S&HR control the analog routing switches as described earlier.

The Delay RAM port connects directly to 5 DRAM chips for delay line storage. U41 - U45 are each 64K by 4 bit DRAMs and are interconnected to make a 64K word by 20-bit memory. U50 sends out a 16-bit address multiplexed on 8 address lines (RMA bus) and reads or writes 20-bit data on the RMD bus. Direct connections for the other DRAM signals (RAS, CAS, and WE) are also provided on the Delay RAM Port. The DRAMs are always being cycled so their CE pins may be simply grounded.

The sample rate for the effects system is 33.3KS/s (Kilo-Samples per second), which is a sample period of 30 microseconds. During each sample period it does one A/D conversion, two D/A conversions, and cycles through the algorithm microprogram once. Figure 7 below shows a timing diagram for one sample period. During the first 3uS the LSI chip closes the input switch (U10 section A) and samples the input signal. The switch is opened and an additional 3uS elapses waiting for the U12-7 op-amp to settle. The last 24uS is spent outputting 16 trial values and reading the result from the comparator as described above. Simultaneously the output of the left channel data is performed for the 3uS while the input is in the sample mode followed by the right channel for 3uS while the input op-amp is settling. Then the cycle repeats. The circuit is always cycling like this even if the Engine Board selects no effects.

## 5.1.6 K2000 AUDIO/POWER THEORY

## SCHEMATIC PAGE 6

## 5.1.6.1 EFFECTS MICROCODE RAM

U50 reads its microcode instructions from a pair of 2Kx8 high-speed static RAM chips, U24 (G-7) and U25 (G-5). Actually, U50 only outputs 8 bits of microcode address; the other 3 are used to identify 1 of 8 stored microcode routines. The SRAM is effectively dual-ported so that the Effects Microprocessor can write into it while the LSI chip reads from it. This is necessary to get the microcode routines loaded initially. Also for chorus and flange effects certain locations with coefficients need to be periodically updated.

Address multiplexors U19, U20 and U22 select between addresses generated by the LSI chip when pin 1 is high and addresses generated by the Effects Microprocessor and latched in U29 and U47 when pin 1 is low. The LSI chip indicates via RVB ENEX when it is not using the microcode RAM. Data into and out of the microcode RAM is multiplexed on the MCD bus. For reading by the LSI chip, the RAM's OE (Output Enable) pin is activated and its WE (Write Enable) pin deactivated. For writing new data, the outputs of data latches U26 and U46 are enabled and the RAM's OE is disabled and WE enabled.

## 5.1.6.2 EFFECTS MICROPROCESSOR

The Effects Microprocessor is responsible for loading the Microcode RAM in response to program change messages from the Engine Board and also periodically updating coefficients for the chorus and flanging effects. It is a 6803 which has an enhanced 6800 core with 128 bytes of RAM, one serial port, and two parallel ports built-in. Program memory is external. Its 4MHz input clock is derived from the 32MHz clock by divider U56 (G-6 of page 2). It is internally divided by 4 again for a 1uS memory cycle and instruction times of 2 - 10uS.

The upper 8 bits of the external address bus are latched on the 6803 and thus can be connected directly to the external address decoder and memories. The lower 8 bits are multiplexed with the data on the DA bus. Address latch U55 (E-1) latches these which are then sent to the address decoder and RAMs. An Address Strobe signal with the correct timing is available directly from the 6803.

Address decoding is performed by the 3 gates (U58 & U57, F-1) and two 1-of-4 decoders (U54, F-2). Gate U58-12 splits the 64K address space into an EPROM area of 56K (addresses \$2000 - \$FFFF) and an "other" area (addresses \$0000 - \$1FFF). Gate U58-6 splits the "other" area into 7K of external RAM from \$0400 - \$1FFF and 1K of I/O and internal RAM between \$0000 and \$03FF. Then the upper decoder (U54-10) splits out the range between \$0200 and \$03FF and the lower decoder splits that 4 ways for addressing 4 output latches (U26, U29, U46, and U47; F-3 to I-3) which interact with the microcode RAM as described earlier.

## 5.1.6.3 EFFECTS MICROPROCESSOR MEMORY

Program ROM for the Effects Microprocessor is a single 64Kx8 EPROM, U48 (G-1 to H-2). Much of this space is taken by the original DSP-256 factory setups which are not used by the K2000. The program code loaded into the EPROM is essentially what DOD supplied with a few minor patches to skip over front panel related functions which would otherwise hang since there is no front panel hardware. The CE pin (20) is used to activate the EPROM when addresses in the range of \$2000 - \$FFFF are generated and the OE pin is used to deactivate it during all write cycles.

U51 (I-1 to I-2) is a low-power static RAM chip and serves both as a scratch RAM for the microprocessor program and as a non-volatile RAM for effects setup storage. Non-volatility is implemented by powering U51 from BUVdd and the use of Q8 (I-2) as a fail-safe, zero power consumption Write Enable gate. During normal operation, RESETb, which is connected to the base of Q8 through R184, is high. Thus when the Write signal from U57-11 goes low to write, Q8 saturates and pulls its collector, which is connected to the WE pin on the RAM low. When Write goes high or RESETb goes low, Q8 is cut off and R185 pulls the WE pin back high thus inhibiting writing. When power off, the emitter is floating and there is no base current so R185 continues to keep WE high with no power consumption (except leakage current).

The Engine Board software depends on the effect RAM being non-volatile. Whenever the Engine software performs a "hard reset", such as after a battery power failure, it will reload the K2000 factory effects setups into this RAM which is a lengthy process.

## 5.1.6.4 INTERFACE TO EFFECTS LSI CHIP

In addition to communication through dual-port microcode RAM, the Effects Microprocessor communicates with the Effects LSI Chip through a few dedicated control signals.

RVB\_GATE is a signal generated by the microprocessor that will smoothly silence any sound that may be reverberating in the chip and also clear the delay RAM. This is exercised whenever the effects algorithm is changed.

## SECTION 5

RVB\_OVFLO is produced by the LSI chip to indicate when the internal digital signal levels are too great. Flip-flop U60-9 (B-4) latches this pulsed signal until the microprocessor can recognize it. After recognition, the microprocessor resets the flip-flop.

Proper timing writes into the microcode RAM are critical and are synchronized with microprocessor operation by several signals and circuits. The LSI chip actually controls the exact timing of the write via the RVB\_MCA and RVB\_MCD busses while the former is the actual Write Enable signal to the microcode RAM. Counters U21 and U23 (B-1 to B-3) are also involved in sequential address generation/

RVB\_MUTE is produced by the Effects Microprocessor from power-up until the Microcode RAM is initialized. The muting function is implemented at B-6 on schematic page 4 by overriding the effects unit output amplifier control voltage via R18 and D1 (B-6 of page 4). When RVB\_MUTE is high, the U32-3 (B-6 on page 4) node is pulled high regardless of DAC1\_OUT and passed to U32-1 which is the control voltage to U8. Since the voltage-controlled amplifiers attenuate for increasing control voltage, U8 is effectively cut off until the microcode RAM can be initialized.

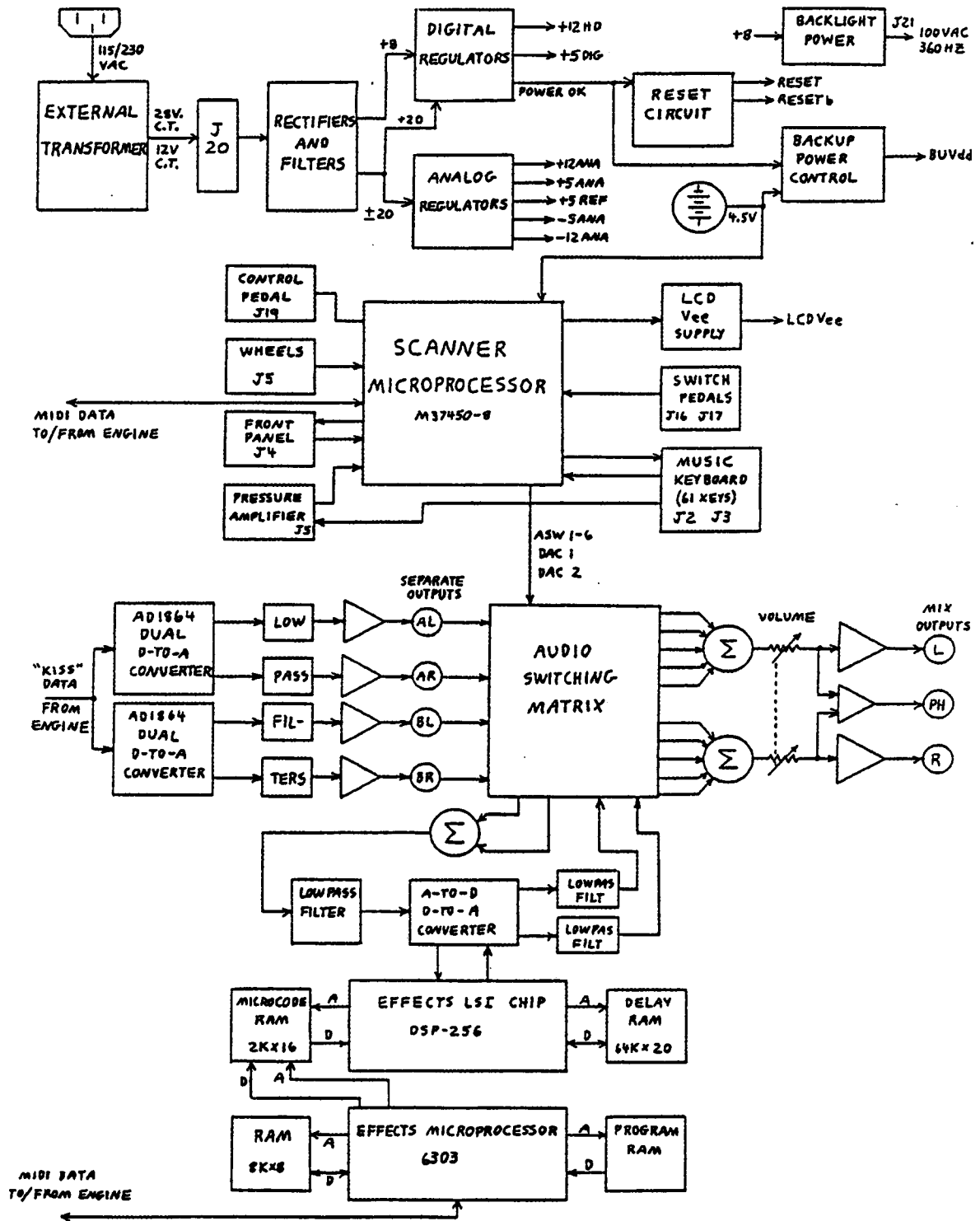

Figure 5.1.6.1 - Audio Board Functional Block Diagram

NOTES

KURZWEIL K2000  
PARTS LIST

LOCATION	PART NO.	DESCRIPTION	QTY.
AUDIO(DIP)	N025315210	MACHINE SCREW FH M2.5x10(YELLOW)	5
AUDIO(DIP)	N025323312	MACHINE SCREW BH M3x12 black	1
AUDIO(DIP)	N033100601	PCB FAB AUDIO BOARD K2000	1
AUDIO(DIP)	N041021128	SOCKET IC .6W 28PIN	1
AUDIO(DIP)	N041030406	HEADER 26-60-4060 .156SP 6POS XFMR	1
AUDIO(DIP)	N041031216	CONN HEAD DUAL ROW .1SP 16P(057-016-153)	2
AUDIO(DIP)	N041031220	CONN HEAD DUAL ROW .1SP 20P(057-020-153)	1
AUDIO(DIP)	N041032632	CONN EUROCARD HALF-B R/A 32P 100-632-553	1
AUDIO(DIP)	N041034002	HEADER 22-03-5025 .098SP 2PIN BATTERY BT	1
AUDIO(DIP)	N041034004	HEADER 22-03-5045 .098SP 4PIN	2
AUDIO(DIP)	N041034007	HEADER 22-03-5075 .098SP 7PIN	2
AUDIO(DIP)	N049010101	TO-220	5
AUDIO(DIP)	N049010102	RES CF 1/8W 5% 2K	5
AUDIO(DIP)	N051000817	RES NET 100 5% 8 PIN	6
AUDIO(DIP)	N051000906	RES 10KX9 10PIN	4
AUDIO(DIP)	N051100107	RES CF 1/8W 5% 47	5
AUDIO(DIP)	N051100113	RES CF 1/8W 5% 100	6
AUDIO(DIP)	N051100120	RES CF 1/8W 5% 330	3
AUDIO(DIP)	N051100124	RES CF 1/8W 5% 470	3
AUDIO(DIP)	N051100132	RES CF 1/8W 5% 1K	8
AUDIO(DIP)	N051100137	RES CF 1/8W 5% 2K	6
AUDIO(DIP)	N051100138	RES CF 1/8W 5% 2.2K	6
AUDIO(DIP)	N051100142	RES CF 1/8W 5% 3.3K	1
AUDIO(DIP)	N051100145	RES CF 1/8W 5% 4.7K	8
AUDIO(DIP)	N051100151	RES CF 1/8W 5% 7.5K	1
AUDIO(DIP)	N051100156	RES CF 1/8W 5% 13K	1
AUDIO(DIP)	N051100157	RES CF 1/8W 5% 10K	17
AUDIO(DIP)	N051100162	RES CF 1/8W 5% 22K	2
AUDIO(DIP)	N051100167	RES CF 1/8W 5% 39K	2
AUDIO(DIP)	N051100178	RES CF 1/8W 5% 91K	2
AUDIO(DIP)	N051100179	RES CF 1/8W 5% 100K	13
AUDIO(DIP)	N051100181	RES CF 1/8W 5% 120k	1
AUDIO(DIP)	N051100186	RES CF 1/8W 5% 220K	4
AUDIO(DIP)	N051100187	RES CF 1/8W 5% 300K	1
AUDIO(DIP)	N051100189	RES CF 1/8W 5% 470K	2
AUDIO(DIP)	N051100192	RES CF 1/8W 5% 1.0M	2
AUDIO(DIP)	N051100195	RES CF 1/8W 5% 4.7M	1
AUDIO(DIP)	N051100305	RES MF 1/8W 1% 200	8
AUDIO(DIP)	N051100310	RES MF 1/8W 1% 1.00K	3
AUDIO(DIP)	N051100311	RES MF 1/8W 1% 1.10K	4
AUDIO(DIP)	N051100315	RES MF 1/8W 1% 1.30K	4
AUDIO(DIP)	N051100328	RES MF 1/8W 1% 3.32K	16
AUDIO(DIP)	N051100330	RES MF 1/8W 1% 3.74K	18
AUDIO(DIP)	N051100336	RES MF 1/8W 1% 4.99K	4
AUDIO(DIP)	N051100342	RES MF 1/8W 1% 6.81K	8
AUDIO(DIP)	N051100353	RES MF 1/8W 1% 11.3K	7
AUDIO(DIP)	N051100356	RES MF 1/8W 1% 15.0K	34
AUDIO(DIP)	N051100360	RES MF 1/8W 1% 20.0K	2



**SECTION 6****KURZWEIL K2000**

K2000P.WK1

**PARTS LIST**

LOCATION	PART NO.	DESCRIPTION	QTY.
AUDIO(DIP)	N051100526	RES CF 1/4W 5% 620	6
AUDIO(DIP)	N051100903	RES CF 1/2W 5% 10	1
AUDIO(DIP)	N051100907	RES CF 1/2W 5% 47	2
AUDIO(DIP)	N051101401	TRIMPOT 6mm CARBON PCMT 100K	3
AUDIO(DIP)	N051101402	TRIMPOT 6mm 5K, SUBMINI	1
AUDIO(DIP)	N051101403	TRIMPOT 6mm 10K, SUBMINI	1
AUDIO(DIP)	N051101405	TRIMPOT 1K	1
AUDIO(DIP)	N052001204	CAP CERMONO .1UF 50V 20% .3AX	95
AUDIO(DIP)	N052001712	CAP ELECT 1000uF 25V 20% RAD	1
AUDIO(DIP)	N052001713	CAP ELECT 4700uF 25V 20% RAD	1
AUDIO(DIP)	N052002201	CAP ELECT 100UF 16V RAD	8
AUDIO(DIP)	N052003505	CAP POLYEST FILM .0047UF 50V 5% RAD	6
AUDIO(DIP)	N052003506	CAP POLYEST FILM .01UF 50V 5% RAD	1
AUDIO(DIP)	N052003510	CAP POLYEST FILM .0056UF 50V 5% RAD	6
AUDIO(DIP)	N052003522	CAP POLYEST FILM 0.0012uF 50V 5% RAD	2
AUDIO(DIP)	N052003523	CAP POLYEST FILM 0.0022uF 50V 5% RAD	4
AUDIO(DIP)	N052003524	CAP POLYEST FILM 0.0082uF 50V 5% RAD	2
AUDIO(DIP)	N052003526	CAP POLYEST FILM 0.018uF 50V 5% RAD	10
AUDIO(DIP)	N052003527	CAP POLYEST FILM 0.0027uF 50V 5% RAD	4
AUDIO(DIP)	N052004201	CAP ELECT 10UF 35V 20% .08SP	9
AUDIO(DIP)	N052004205	CAP ELECT 4.7uF 35V 20% RAD	1
AUDIO(DIP)	N052005202	CAP ELECT 2200UF 16V 20% SNAP-IN	1
AUDIO(DIP)	N052005303	CAP CERMONO 100PF 200V 5% NPO AX	26
AUDIO(DIP)	N052005304	CAP CERMONO 220PF 200V 5% NPO AX	15
AUDIO(DIP)	N052005306	CAP CERMONO 680PF 5% NPO AX	2
AUDIO(DIP)	N052005307	CAP CERMONO 4.7pF 200V 5% AX	1
AUDIO(DIP)	N052005401	CAP CERMONO 1000PF 100V 10% X7R AX	12
AUDIO(DIP)	N052005402	CAP CERMONO 470PF 100V 10% X7R AX	1
AUDIO(DIP)	N052005702	CAP POLYEST FILM 0.015uF 100V 5% RAD	1
AUDIO(DIP)	N052005901	CAP ELECT 2200uF 6V RAD	1
AUDIO(DIP)	N052006001	CAP ELECT 220uF 10V RAD	1
AUDIO(DIP)	N053000401	DIODE (1N270)	6
AUDIO(DIP)	N053000701	DIODE 1N4001 DO-41	5
AUDIO(DIP)	N053000801	DIODE SWITCH (1N4148)	14
AUDIO(DIP)	N053001001	DIODE ZENER 6.2V (1N5234B)	1
AUDIO(DIP)	N053002201	DIODE DUAL SCHOTTKY (MBR1535)	1
AUDIO(DIP)	N053010501	DIODE PWR SHOTTKY 1A 20V (1N5817)	1
AUDIO(DIP)	N053020201	DIODE AMP 1N5401(3A)	2
AUDIO(DIP)	N054000602	TRANSISTOR PN2907 TO-92	2
AUDIO(DIP)	N054000801	TRANSISTOR GP NPN (PN2222)	8
AUDIO(DIP)	N054010101	TRANSISTOR KSA931	2
AUDIO(DIP)	N054010301	TRANSISTOR KSC2331	4
AUDIO(DIP)	N054010601	TRANSISTOR NJFET J109 TO-92	8
AUDIO(DIP)	N054010701	TRANSISTOR PWR NVFET IRFZ20	1
AUDIO(DIP)	N055002001	INDUCTOR (BLO2RN2-R62)	1
AUDIO(DIP)	N055002101	2 1/2 TURN FERRITE BEAD	5
AUDIO(DIP)	N055002301	TRANSFORMER EL POWER 60 SQ CM	1
AUDIO(DIP)	N059002002	FILTER LOWPASS 20.8K TFB-3	4

## PARTS LIST

LOCATION	PART NO.	DESCRIPTION	QTY.
AUDIO (DIP)	N061000301	IC LOGIC LS (74LS145)	1
AUDIO (DIP)	N061010301	IC LOGIC (74HCU04)	1
AUDIO (DIP)	N061016001	IC LOGIC 74HC00	1
AUDIO (DIP)	N061016101	IC LOGIC (74HC374)	4
AUDIO (DIP)	N061016301	IC LOGIC 74HC139	1
AUDIO (DIP)	N061018901	IC 74AC02	1
AUDIO (DIP)	N061019101	IC 74AC10	1
AUDIO (DIP)	N061019201	IC 74HC27	1
AUDIO (DIP)	N061019501	IC 74AC157	3
AUDIO (DIP)	N061019601	IC 74HC191	2
AUDIO (DIP)	N061019801	IC 74HC393	1
AUDIO (DIP)	N061019901	IC 74HC273	2
AUDIO (DIP)	N061020001	IC LOGIC HC 74HC04	1
AUDIO (DIP)	N061020201	IC LOGIC HC 74HC74	2
AUDIO (DIP)	N061020501	IC LOGIC 74HC373 DIP20	1
AUDIO (DIP)	N062004301	IC EPROM 27C512	1
AUDIO (DIP)	N062005001	IC MEMORY SRAM 8Kx8 150ns (6264) .3W	1
AUDIO (DIP)	N062100302	IC MEM SRAM 2KX8 150NS (6116 3W)	2
AUDIO (DIP)	N062100401	IC MEM DRAM 64KX4 120NS 4464 LOW POWER T	5
AUDIO (DIP)	N063010101	IC INTERFACE DAC (PCM54H)	1
AUDIO (DIP)	N064001201	IC LINEAR -5 100MA 5% (LM79L05)	1
AUDIO (DIP)	N064001301	IC LINEAR +5 100MA 5% (LM78L05) TO-92	2
AUDIO (DIP)	N064001601	IC LINEAR (TL072)	5
AUDIO (DIP)	N064002801	IC LINEAR (NE5532AN)	7
AUDIO (DIP)	N064010001	IC LINEAR OP-AMP JFET (TL074CP)	3
AUDIO (DIP)	N064010201	IC LINEAR LF351N	1
AUDIO (DIP)	N064010402	IC LINEAR 79L15 TO-92	1
AUDIO (DIP)	N064010601	IC 74HC4053	4
AUDIO (DIP)	N064010701	IC LF357N	1
AUDIO (DIP)	N064010801	IC 7812 TO-220	2
AUDIO (DIP)	N064010901	IC 7912 TO-220	1
AUDIO (DIP)	N241034501	JACK 1/4"	10
AUDIO (DIP)	N263010302	IC DAC AD1865	2
AUDIO (DIP)	N264010501	VCA SSM2122	2
AUDIO (DIP)	N264011101	PMI CMP01	1
AUDIO (SMD)	N262100001	IC REVERB DSP-256-HISC (VGT10-064)	1
AUDIO (SMD)	N262100501	CPU HD63A03 / 63B03	1
AUDIO (SMD)	N262100601	CPU M37450M8	1
BATTERY HOLDER	N013022201	CABLE ASSY BATTERY K2000	1
BATTERY HOLDER	N235040001	BATTERY HOLLDER 33-4 BLACK	1
CONTROL PANEL	N035021121	BUTTON (1) BLACK	18
CONTROL PANEL	N038000301	BUTTON (1) BLACK	1
CONTROL PANEL	N038000302	BUTTON (2) BLACK	1
CONTROL PANEL	N038000303	BUTTON (3) BLACK	1
CONTROL PANEL	N038000304	BUTTON (4) BLACK	1
CONTROL PANEL	N038000305	BUTTON (5) BLACK	1
CONTROL PANEL	N038000306	BUTTON (6) BLACK	1
CONTROL PANEL	N038000307	BUTTON (7) BLACK	1

## PARTS LIST

LOCATION	PART NO.	DESCRIPTION	QTY.
CONTROL PANEL	N038000308	BUTTON (8) BLACK	1
CONTROL PANEL	N038000309	BUTTON (9) BLACK	1
CONTROL PANEL	N038000310	BUTTON (10) BLACK	1
CONTROL PANEL	N038000311	BUTTON (+/-) black	1
CONTROL PANEL	N038000312	BUTTON (CLR) BLACK	1
CONTROL PANEL	N038000313	BUTTON ( ) BLACK	2
CONTROL PANEL	N038000314	BUTTON ( ) BLACK	2
CONTROL PANEL	N038000315	BUTTON ( ) BLACK (ABS)	2
CONTROL PANEL	N038000319	BUTTON (CANCEL) ABS	1
CONTROL PANEL	N038000320	BUTTON (ENTER) ABS	1
CONTROL PANEL	N041033520	HEADER .1SP DUAL ROW RIGHT ANGLE 20 POS	1
CONTROL PANEL	N044010501	ENCODER 36STEP 2BIT GRAY CODE OUT	1
CONTROL PANEL	N045010501	LED T1-3/4 RED GaAsP/GaP	8
CONTROL PANEL	N243010401	TACT S/W "ALPS" 418A SKHCAA	38
CONTROL PANEL	N024020003	CUSHION 14 X 8T (YDP)	4
CONTROL PANEL	N125225408	TAPPING SCREW 2A* BH 3X8 AN(PLASTIC	9
DISK DRIVE BRACKET	N013021901	CABLE ASSY DATA FLOPPY DISK DRIVE K2000	1
DISK DRIVE BRACKET	N013022401	CABLE ASSY POWER FLOPPY DISK DRIVE K2000	1
DISK DRIVE BRACKET	N025325306	MACHINE SCREW BH M3x6 (YELLOW)	6
DISK DRIVE BRACKET	N032022011	BRACKET MOUNTING DISK DRIVE	2
DISK DRIVE BRACKET	N032026921	FDD BRACKET 38.5X101.5	1
DISK DRIVE BRACKET	N125225408	TAPPING SCREW 2A* BH 3X8 AN(PLASTIC	2
DISK DRIVE BRACKET	N215000601	FDD 3.5" DS HD 1" HIGH W/BLACK BEZEL	1
ENGINE	N012103402	K2000 ENGINE(DIP)	1
ENGINE	N012103403	K2000 ENGINE(SMD)	1
ENGINE (DIP)	N026263105	TAPPING SCREW-2 PH #2X3/16(2.18x4.5) BLK	6
ENGINE (DIP)	N032022911	REAR PANEL,DIGITAL PCB (YELLOW)	1
ENGINE (DIP)	N033100401	P.C.B;ENGINE K-2000/K2000R	1
ENGINE (DIP)	N041010302	CONN JUMPER.1SP 2 POS	2
ENGINE (DIP)	N041021005	JACK MIDI 5 PIN (PCB 2#)	3
ENGINE (DIP)	N041021120	SOCKET IC .3W 20PIN	1
ENGINE (DIP)	N041021122	SOCKET IC .3W 24 PIN	3
ENGINE (DIP)	N041021132	SOCKET IC .6W 32PIN	4
ENGINE (DIP)	N041030003	HEADER .1SP 3POS(22-03-2031)	2
ENGINE (DIP)	N041031220	CONN HEAD DUAL ROW .1SP 20P(057-020-153)	2
ENGINE (DIP)	N041031234	HEAD DUAL ROW .1SP SHROUD34P(057-034-153)	2
ENGINE (DIP)	N041031250	CONN HEAD DUAL ROW .1SP SHROUD 50P	1
ENGINE (DIP)	N041032425	CONN DB-25 PLASTIC SHORT R/A PCMT	1
ENGINE (DIP)	N041032564	CONN EUROCARD DIN B 64PIN FEMALE100-064-	1
ENGINE (DIP)	N041032732	CONN EUROCARD HALF-B MALE R/A32P100-632-	1
ENGINE (DIP)	N041032848	CONN EUROCARD HALF-C FEMALE 48P	1
ENGINE (DIP)	N041032906	CONN HEADER .1SP DUAL ROW 6 PIN	1
ENGINE (DIP)	N041033208	SOCKET SIP .1SP 8 PIN	3
ENGINE (DIP)	N041033330	SOCKET SIMM 30 PIN DUAL .3 SP	2
ENGINE (DIP)	N041034004	HEADER 22-03-5045 .098SP 4PIN	1
ENGINE (DIP)	N051001202	RESNET BUSSED 120X7 SIP8(MSP08A-01-121G)	3
ENGINE (DIP)	N052002201	CAP ELECT 100UF 16V RAD	1
ENGINE (DIP)	N052002406	CAP ELECT 470UF 16V 20% .2 SP	1

LOCATION	PART NO.	DESCRIPTION	QTY.
ENGINE (DIP)	N053000401	DIODE (1N270)	2
ENGINE (DIP)	N053000701	DIODE 1N4001 DO-41	1
ENGINE (DIP)	N053000801	DIODE SWITCH (1N4148)	1
ENGINE (DIP)	N055002001	INDUCTOR (BLO2RN2-R62)	7
ENGINE (DIP)	N059010002	CRYSTAL 19.968MHZ	1
ENGINE (DIP)	N059010103	CRYSTAL 32.000MHZ 3rd OT, SERIES	1
ENGINE (DIP)	N062005702	IC PAL GAL16V8-15LP	1
ENGINE (DIP)	N062005902	IC PAL GAL20V8-15LP	3
ENGINE (DIP)	N062200501	IC ROM-4MB (K2000)	2
ENGINE (DIP)	N063002301	IC OPTO COUPLER (PC-910)	1
ENGINE (DIP)	N125225416	TAPPING SCREW-2 BH 3X16 AN(PLASTIC)	6
ENGINE (DIP)	N263010501	IC TL SCSI 1285KC	1
ENGINE (SMD)	N051001001	RESNET BUS 10Kx15 SOP16 SOMC-1601-103J	3
ENGINE (SMD)	N051001002	RESNET BUSSED 4.7Kx15 SOP16	1
ENGINE (SMD)	N051101708	RES 56 5% THICK FILM 1206	4
ENGINE (SMD)	N051101714	RES CF 110 5% THICK FILM 1206	8
ENGINE (SMD)	N051101715	RES 120 5% THICK FILM 1206	1
ENGINE (SMD)	N051101724	RES CF 470 5% THICK FILM 1206	2
ENGINE (SMD)	N051101734	RES 1.5K 5% THICK FILM 1206	2
ENGINE (SMD)	N051101738	RES CF 2.2K 5% THICK FILM 1206	7
ENGINE (SMD)	N051101740	RES 2.7K 5% THICK FILM 1206	3
ENGINE (SMD)	N051101741	RES 3K 5% THICK FILM 1206	1
ENGINE (SMD)	N051101745	RES CF 4.7K 5% THICK FILM 1206	6
ENGINE (SMD)	N051101748	RES 6.2K 5% THICK FILM 1206	1
ENGINE (SMD)	N051101757	RES CF 10K 5% THICK FILM 1206	2
ENGINE (SMD)	N051101797	RES CF 10M 5% THICK FILM 1206	1
ENGINE (SMD)	N052007001	CAP CER 15pF 100V 5% NPO 1206	1
ENGINE (SMD)	N052007002	CAP CER 22pF 100V 5% NPO 1206	1
ENGINE (SMD)	N052007003	CAP CER 47pF 100V 5% NPO 1206	5
ENGINE (SMD)	N052007004	CAP CER 1000pF 100V 5% NPO 1206	13
ENGINE (SMD)	N052007101	CAP CER .1uF 50V 5% Z5U 1206	63
ENGINE (SMD)	N054000802	TRANS MMBT2222L SOT-23	1
ENGINE (SMD)	N061000202	IC LOGIC 74LS138 SOP	1
ENGINE (SMD)	N061001302	IC LOGIC 74LS04 SOP	1
ENGINE (SMD)	N061001502	IC LOGIC 74LS74A SOP	1
ENGINE (SMD)	N061001602	IC LOGIC 74LS32 SOP	2
ENGINE (SMD)	N061003002	IC LOGIC 74LS245 SOP	3
ENGINE (SMD)	N061010302	IC LOGIC 74HCU04 SOP	2
ENGINE (SMD)	N061018302	IC LOGIC 74HC08 SOP	1
ENGINE (SMD)	N061018402	IC LOGIC 74LS241 SOP	3
ENGINE (SMD)	N061018502	IC LOGIC 74F139 SOP	1
ENGINE (SMD)	N061018602	IC LOGIC 74F174 SOP	2
ENGINE (SMD)	N061018702	IC LOGIC 74LS174 SOP	1
ENGINE (SMD)	N251001102	RESISTOR NETWORK 120X15SOP SOMC1601-121	1
ENGINE (SMD)	N261017502	IC 74LS541	9
ENGINE (SMD)	N262001002	IC 68301	1
ENGINE (SMD)	N262100801	IC SRAM TC518128S	2
ENGINE (SMD)	N263010201	IC L53C80JC2 PLCC44	1

## SECTION 6

## KURZWEIL K2000

K2000P.WK1

## PARTS LIST

LOCATION	PART NO.	DESCRIPTION	QTY.
ENGINE (SMD)	N263010401	IC UPD72064	1
ENGINE (SMD)	N266000302	IC CUSTOM HOBBS CHIP	2
ENGINE (SMD)	N266000401	IC CUSTOM CALVIN CHIP	1
ENGINE (SMD)	N283010601	MASK ROM 1A	1
ENGINE (SMD)	N283010701	MASK ROM 1B	1
ENGINE (SMD)	N283010801	MASK ROM 2A	1
ENGINE (SMD)	N283010901	MASK ROM 2B	1
ENGINE (SMD)	N283011001	MASK ROM 3A	1
ENGINE (SMD)	N283011101	MASK ROM 3B	1
ENGINE (SMD)	N283011201	MASK ROM 4A	1
ENGINE (SMD)	N283011301	MASK ROM 4B	1
KEYBOARD	N013022801	CABLE ASSY KEYBOARD K2000	2
KEYBOARD	N215040221	KEYBOARD 61°C TP-9	1
LCD	N245010402	BACKLIGHT EL 136X40MM LFOB09	1
LCD	N013022001	CABLE ASSY LCD K2000	1
LCD	N013022301	CABLE ASSY LCD BACKLIGHT K2000	1
LCD	N015048223	LCD BACKLIGHT FELT (0.5X10X40)	0.01
LCD	N015048224	LCD FELT (1TX12X430)	0.04
LCD	N092000504	LCD (0.05X100X200)	0.01
LCD	N024501030	DISPLAY LCD 240X64 W/CTR LM24014H	1
LCD	N245010402	BACKLIGHT EL 136X40MM LFOB09	1
MAIN	N012103401	ENGINE ASSY K-2000 (COMPLETE ASSY.)	1
MAIN	N012103601	AUDIO ASSY K-2000 (COMPLETE ASSY.)	1
MAIN	N032022511	HEAT SINK (ALUMINUM)	1
PITCH & MOD	N013022901	CABLE ASSY PITCH&MOD VOLUME K2000	1
PITCH & MOD	N025225408	TAPPING SCREW-2 BH 3x8 AN(YELLOW)	2
PITCH & MOD	N025325308	MACHINE SCREW-2 BH 3x8 AN(YELLOW)	2
PITCH & MOD	N032021711	BRACKET MOUNTING PITCH & MOD (YELLOW)	1
PITCH & MOD	N032021811	BUSHING	1
PITCH & MOD	N032021911	SPRING TORSION (MUSIC WIRE)	1
PITCH & MOD	N033100801	PCB FAB PITCH & MOD K2000	1
PITCH & MOD	N035020311	WHEEL 35EAAI (BLACK)	2
PITCH & MOD	N041030507	CONN HEADER .098SP SGL ROW 7 PIN	1
PITCH & MOD	N041033104	HEADER .1SP 4POS WHITE RIGHT ANGLE	1
PITCH & MOD	N051100151	RES CF 1/8W 5% 7.5K	2
PITCH & MOD	N051100179	RES CF 1/8W 5% 100K	2
PITCH & MOD	N051100336	RES MF 1/8W 1% 4.99K	2
PITCH & MOD	N051101402	TRIMPOT 6mm 5K, SUBMINI	4
PITCH & MOD	N051102301	POT ROTARY 10K K2000	2
POWER ENTRY MODULE	N043010601	FUSE NORMAL-BLO 5X30mm 115V RATING 1A	1
POWER ENTRY MODULE	N052005502	CAP 470PF 250V AC	2
POWER ENTRY MODULE	N241033601	POWER MODULE 5EFM4S K2000	2
POWER ENTRY MODULE	N043010603	FUSE 240V 0.63A	2
POWER ENTRY MODULE	N052005502	CAP 470PF 250V AC	2
POWER ENTRY MODULE	N241033601	POWER MODULE 5EFM4S K2000	1
POWER ENTRY MODULE	N025323312	MACHINE SCREW BH M3x12 black	2
POWER ENTRY MODULE	N025874300	NUT HEX M3 WHITE	2
POWER ENTRY MODULE	N027112100	FLAT WASHER 3.3X6.5X0.5 BLK	2

**SECTION 6****KURZWEIL K2000  
PARTS LIST**

K2000P.WK1

<b>LOCATION</b>	<b>PART NO.</b>	<b>DESCRIPTION</b>	<b>QTY.</b>
POWER ENTRY MODULE	N027213140	SPLIT LOCK WASHER 3.1x5.9x0.7 BLK	2
SLIDER VOLUME	N033100901	PCB FAB SLIDER VOLUME K2000	1
SLIDER VOLUME	N039000701	SLIDE VOLUME FELT (0.3tX12X70)	0.14
SLIDER VOLUME	N041034107	CONNECTOR .098SP SGL ROW RIGHT ANGLE 7 P	1
SLIDER VOLUME	N251101501	SLIDER VOLUME 10KB EWA-PDO S10-U14	1
SLIDER VOLUME	N251101603	POT SLIDER 20K 45MM EWA-PBO S10-U24	1
TRANS	N025325440	MACHINE SCREW BH M4X40 (YELLOW)	4
TRANS	N027113160	FLAT WASHER 4.5X10X0.5 AN BLK	4
TRANS	N027213160	SPLIT LOCK WASHER 4.2X7.3X1 AN BLK	4
TRANS & POWER	N012104101	POWER ENTRY MODLE K-2000	1
TRANS & POWER	N012104201	TRANS ASSY K-2000	1
TRANS & POWER	N012104102	POWER ENTRY MODLE K-2000	1
TRANS & POWER	N012104201	TRANS ASSY K-2000	1
TRANS ASSY	N013022501	CABLE ASSY SAFETY GROUND K2000	1
TRANS ASSY	N013022601	CABLE ASSY TRANSFORMER POWER PRIMARY K20	1
TRANS ASSY	N013022701	CABLE ASSY TRANSFORMER POWER SECONDARY K	1
TRANS ASSY	N015000501	TRANSFORMER POWER K2000	1
TRANS ASSY	N092100404	TUBING HEAT SINK	0.02

SECTION 6

KURZWEIL K2000  
PARTS LIST

K2000P.WK1

LOCATION

PART NO.

DESCRIPTION

QTY.

---

LOCATION	PART NO.	DESCRIPTION	QTY
AUDIO(DIP)	N025324301	MACHINE SCREW RH7 3X10 WHITE	5
AUDIO(DIP)	N025874300	NUT HEX M3 WHITE	2
AUDIO(DIP)	N027112100	FLAT WASHER 3.3X6.5X0.5 BLK	5
AUDIO(DIP)	N027213140	SPLIT LOCK WASHER 3.1x5.9x0.7 BLK	5
AUDIO(DIP)	N032020004	HEAT SHINK K2000R	1
AUDIO(DIP)	N033101001	PCB FAB AUDIO BOARD K2000R REV	1
AUDIO(DIP)	N041021128	SOCKET IC .6W 28PIN	2
AUDIO(DIP)	N041030406	HEADER 26-60-4060 .156SP 6POS XFMR	1
AUDIO(DIP)	N041031220	CONN HEAD DUAL ROW .1SP 20P(057-020-153)	1
AUDIO(DIP)	N041031234	HEAD DUAL ROW .1SP SHROUD34P(057-034-153)	1
AUDIO(DIP)	N041031240	CONN HEADER .1SP DUAL ROW 40 PIN AUDIO T	1
AUDIO(DIP)	N041034002	HEADER 22-03-5025 .098SP 2PIN BATTERY BT	2
AUDIO(DIP)	N041034003	HEADER 22-03-5035 .098SP 3PIN	1
AUDIO(DIP)	N041034004	HEADER 22-03-5045 .098SP 4PIN	1
AUDIO(DIP)	N041034005	HEADER 22-03-5055 .098SP 5PIN	1
AUDIO(DIP)	N041034007	HEADER 22-03-5075 .098SP 7PIN	1
AUDIO(DIP)	N049010101	TO-220	5
AUDIO(DIP)	N051000906	RES 10KX9 10PIN	4
AUDIO(DIP)	N051100107	RES CF 1/8W 5% 47	5
AUDIO(DIP)	N051100113	RES CF 1/8W 5% 100	6
AUDIO(DIP)	N051100120	RES CF 1/8W 5% 330	2
AUDIO(DIP)	N051100124	RES CF 1/8W 5% 470	2
AUDIO(DIP)	N051100132	RES CF 1/8W 5% 1K	6
AUDIO(DIP)	N051100137	RES CF 1/8W 5% 2K	4
AUDIO(DIP)	N051100138	RES CF 1/8W 5% 2.2K	6
AUDIO(DIP)	N051100142	RES CF 1/8W 5% 3.3K	1
AUDIO(DIP)	N051100145	RES CF 1/8W 5% 4.7K	7
AUDIO(DIP)	N051100151	RES CF 1/8W 5% 7.5K	1
AUDIO(DIP)	N051100157	RES CF 1/8W 5% 10K	19
AUDIO(DIP)	N051100162	RES CF 1/8W 5% 22K	2
AUDIO(DIP)	N051100167	RES CF 1/8W 5% 39K	2
AUDIO(DIP)	N051100178	RES CF 1/8W 5% 91K	2
AUDIO(DIP)	N051100179	RES CF 1/8W 5% 100K	8
AUDIO(DIP)	N051100181	RES CF 1/8W 5% 120k	1
AUDIO(DIP)	N051100186	RES CF 1/8W 5% 220K	4
AUDIO(DIP)	N051100188	RES CF 1/8W 5% 330K	1
AUDIO(DIP)	N051100189	RES CF 1/8W 5% 470K	2
AUDIO(DIP)	N051100192	RES CF 1/8W 5% 1.0M	2
AUDIO(DIP)	N051100195	RES CF 1/8W 5% 4.7M	1
AUDIO(DIP)	N051100305	RES MF 1/8W 1% 200	8
AUDIO(DIP)	N051100310	RES MF 1/8W 1% 1.00K	3
AUDIO(DIP)	N051100311	RES MF 1/8W 1% 1.10K	4
AUDIO(DIP)	N051100315	RES MF 1/8W 1% 1.30K	4
AUDIO(DIP)	N051100328	RES MF 1/8W 1% 3.32K	32
AUDIO(DIP)	N051100330	RES MF 1/8W 1% 3.74K	18
AUDIO(DIP)	N051100336	RES MF 1/8W 1% 4.99K	4
AUDIO(DIP)	N051100342	RES MF 1/8W 1% 6.81K	16
AUDIO(DIP)	N051100353	RES MF 1/8W 1% 11.3K	7



## SECTION 6

KURZWEIL K2000R  
PARTS LIST

K2000RP.WK1 12/23/92

LOCATION	PART NO.	DESCRIPTION	QTY
AUDIO(DIP)	N051100356	RES MF 1/8W 1% 15.0K	42
AUDIO(DIP)	N051100360	RES MF 1/8W 1% 20.0K	2
AUDIO(DIP)	N051100372	RES MF 1/8W 1% 60.4K	2
AUDIO(DIP)	N051100903	RES CF 1/2W 5% 10	1
AUDIO(DIP)	N051100907	RES CF 1/2W 5% 47	2
AUDIO(DIP)	N051101401	TRIMPOT 6mm CARBON PCMT 100K	3
AUDIO(DIP)	N051101402	TRIMPOT 6mm 5K,SUBMINI	1
AUDIO(DIP)	N051101403	TRIMPOT 6mm 10K,SUBMINI	1
AUDIO(DIP)	N052001204	CAP CERMONO .1UF 50V 20% .3AX	104
AUDIO(DIP)	N052001712	CAP ELECT 1000uF 25V 20% RAD	1
AUDIO(DIP)	N052001713	CAP ELECT 4700uF 25V 20% RAD	1
AUDIO(DIP)	N052002201	CAP ELECT 100UF 16V RAD	10
AUDIO(DIP)	N052003505	CAP POLYEST FILM .0047UF 50V 5% RAD	6
AUDIO(DIP)	N052003506	CAP POLYEST FILM .01UF 50V 5% RAD	1
AUDIO(DIP)	N052003510	CAP POLYEST FILM .0056UF 50V 5% RAD	10
AUDIO(DIP)	N052003522	CAP POLYEST FILM 0.0012uF 50V 5% RAD	2
AUDIO(DIP)	N052003523	CAP POLYEST FILM 0.0022uF 50V 5% RAD	4
AUDIO(DIP)	N052003524	CAP POLYEST FILM 0.0082uF 50V 5% RAD	2
AUDIO(DIP)	N052003526	CAP POLYEST FILM 0.018uF 50V 5% RAD	10
AUDIO(DIP)	N052003527	CAP POLYEST FILM 0.0027uF 50V 5% RAD	8
AUDIO(DIP)	N052004201	CAP ELECT 10UF 35V 20% .08SP	12
AUDIO(DIP)	N052005203	CAP ELECT 33000uF 16V 20% RAD	1
AUDIO(DIP)	N052005303	CAP CERMONO 100PF 200V 5% NPO AX	2
AUDIO(DIP)	N052005304	CAP CERMONO 220PF 200V 5% NPO AX	24
AUDIO(DIP)	N052005306	CAP CERMONO 680PF 5% NPO AX	2
AUDIO(DIP)	N052005307	CAP CERMONO 4.7pF 200V 5% AX	1
AUDIO(DIP)	N052005408	CAP CERMONO 470PF 100V 5% AX NPO	2
AUDIO(DIP)	N052005901	CAP ELECT 2200uF 6V RAD	1
AUDIO(DIP)	N052006001	CAP ELECT 220uF 10V RAD	1
AUDIO(DIP)	N053000701	DIODE 1N4001 DO-41	5
AUDIO(DIP)	N053000801	DIODE SWITCH (1N4148)	5
AUDIO(DIP)	N053001001	DIODE ZENER 6.2V (1N5234B)	1
AUDIO(DIP)	N053002201	DIODE DUAL SCHOTTKY (MBR1535)	1
AUDIO(DIP)	N053010501	DIODE PWR SHOTTKY 1A 20V (1N5817)	1
AUDIO(DIP)	N053020201	DIODE AMP 1N5401(3A)	2
AUDIO(DIP)	N054000602	TRANSISTOR PN2907 TO-92	2
AUDIO(DIP)	N054000801	TRANSISTOR GP NPN (PN2222)	8
AUDIO(DIP)	N054010101	TRANSISTOR KSA931	2
AUDIO(DIP)	N054010301	TRANSISTOR KSC2331	3
AUDIO(DIP)	N054010601	TRANSISTOR NJFET J109 TO-92	2
AUDIO(DIP)	N054010801	TRANSISTOR PWR NVFET IRFZ30, TO220GDS	1
AUDIO(DIP)	N055002001	INDUCTOR (BLO2RN2-R62)	1
AUDIO(DIP)	N055002101	2 1/2 TURN FERRITE BEAD	7
AUDIO(DIP)	N059002002	FILTER LOWPASS 20.8K TFB-3	8
AUDIO(DIP)	N061000301	IC LOGIC LS (74LS145)	1
AUDIO(DIP)	N061010301	IC LOGIC (74HCU04)	1
AUDIO(DIP)	N061016001	IC LOGIC 74HC00	1
AUDIO(DIP)	N061016101	IC LOGIC (74HC374)	4

LOCATION	PART NO.	DESCRIPTION	QTY
AUDIO(DIP)	N061016301	IC LOGIC 74HC139	1
AUDIO(DIP)	N061018901	IC 74AC02	1
AUDIO(DIP)	N061019101	IC 74AC10	1
AUDIO(DIP)	N061019201	IC 74HC27	1
AUDIO(DIP)	N061019501	IC 74AC157	3
AUDIO(DIP)	N061019601	IC 74HC191	2
AUDIO(DIP)	N061019801	IC 74HC393	1
AUDIO(DIP)	N061019901	IC 74HC273	2
AUDIO(DIP)	N061020001	IC LOGIC HC 74HC04	1
AUDIO(DIP)	N061020201	IC LOGIC HC 74HC74	2
AUDIO(DIP)	N061020401	IC LOGIC HC 74HC174	1
AUDIO(DIP)	N061020501	IC LOGIC 74HC373 DIP20	1
AUDIO(DIP)	N062004301	IC EPROM 27C512	1
AUDIO(DIP)	N062005001	IC MEMORY SRAM 8Kx8 150nS(6264) .3W	1
AUDIO(DIP)	N062100302	IC MEM SRAM 2KX8 150NS(6116 3W)	2
AUDIO(DIP)	N062100401	IC MEM DRAM 64KX4 120NS 4464 LOW POWER T	5
AUDIO(DIP)	N062200301	IC EPROM 27C128	1
AUDIO(DIP)	N063010101	IC INTERFACE DAC (PCM54H)	1
AUDIO(DIP)	N063010302	IC INTERFACE DAC DUAL (AD1865)	4
AUDIO(DIP)	N064001301	IC LINEAR +5 100MA 5%(LM78L05) TO-92	1
AUDIO(DIP)	N064001401	IC LINEAR VOL REG -5V TO-202(LM79M05ACZ)	1
AUDIO(DIP)	N064001501	IC LINEAR VOL REG +5V TO-202(LM78M05ACZ)	1
AUDIO(DIP)	N064001601	IC LINEAR (TL072)	5
AUDIO(DIP)	N064002801	IC LINEAR (NES532AN)	11
AUDIO(DIP)	N064010001	IC LINEAR OP-AMP JFET (TL074CP)	3
AUDIO(DIP)	N064010201	IC LINEAR LF351N	1
AUDIO(DIP)	N064010402	IC LINEAR 79L15 TO-92	1
AUDIO(DIP)	N064010601	IC 74HC4053	6
AUDIO(DIP)	N064010701	IC LF357N	1
AUDIO(DIP)	N064010801	IC 7812 TO-220	2
AUDIO(DIP)	N064010901	IC 7912 TO-220	1
AUDIO(DIP)	N264010501	VCA SSM2122	2
AUDIO(DIP)	N264011101	PMI CMP01	1
AUDIO(SMD)	N262100001	IC REVERB DSP-256-HISC(VGT10-064)	1
AUDIO(SMD)	N262100501	CPU HD63A03 / 63B03	1
AUDIO(SMD)	N262100601	CPU M37450M8	1
BACKLIGHT INVERTER	N013031201	CABLE AUDIO TO BACKLIGHT 2P 36Cm 2000R	1
BACKLIGHT INVERTER	N041034004	HEADER 22-03-5045 .098SP 4PIN	1
BACKLIGHT INVERTER	N051100120	RES CF 1/8W 5% 330	1
BACKLIGHT INVERTER	N051100145	RES CF 1/8W 5% 4.7K	1
BACKLIGHT INVERTER	N052003002	CAP ELECT 1000UF 10V 10mm DIA 5mm SP	1
BACKLIGHT INVERTER	N052004205	CAP ELECT 4.7uF 35V 20% RAD	1
BACKLIGHT INVERTER	N052005702	CAP POLYEST FILM 0.015uF 100V 5% RAD	1
BACKLIGHT INVERTER	N054010301	TRANSISTOR KSC2331	1
BACKLIGHT INVERTER	N055002301	TRANSFORMER EL POWER 60 SQ CM	1
BATTERY HOLDER ASSY	N013030201	CABLE BATTERY 2P 10Cm(A1*Y2*) 2000R	1
BATTERY HOLDER ASSY	N059010302	BATTERY 1.5V AA(A1*Y2*)	3
BATTERY HOLDER ASSY	N235040101	BATTERY HOLDER B/13 2000R	1

## SECTION 6

KURZWEIL K2000R  
PARTS LIST

K2000RP.WK1 12/23/92

LOCATION	PART NO.	DESCRIPTION	QTY
CONNECTER BOARD	N041031240	CONN HEADER .1SP DUAL ROW 40 PIN AUDIO T	1
CONNECTER BOARD	N041031250	CONN HEAD DUAL ROW .1SP SHROUD 50P	2
CONNECTER BOARD	N041032425	CONN DB-25 PLASTIC SHORT R/A PCMT	1
CONNECTER BOARD	N042005401	JUMPER WIRE 13MM X 4MM	19
CONNECTER BOARD	N051100179	RES CF 1/8W 5% 100K	1
CONNECTER BOARD	N051100526	RES CF 1/4W 5% 620	10
CONNECTER BOARD	N052005401	CAP CERMONO 1000PF 100V 10% X7R AX	10
CONNECTER BOARD	N053000801	DIODE SWITCH (1N4148)	1
CONNECTER BOARD	N054010601	TRANSISTOR NJFET J109 TO-92	10
CONNECTER BOARD	N241034501	JACK 1/4"	10
CONTROL	N013030701	CABLE CONTROL PANEL 20P 58Cm 2000R	1
CONTROL	N025323304	MACHINE SCREW BH M3X4 BLK	16
CONTROL	N025693321	HEX SPACER 5MM	2
CONTROL	N035021121	BUTTON black	18
CONTROL	N038000301	BUTTON (1) BLACK	1
CONTROL	N038000302	BUTTON (2) BLACK	1
CONTROL	N038000303	BUTTON (3) BLACK	1
CONTROL	N038000304	BUTTON (4) BLACK	1
CONTROL	N038000305	BUTTON (5) BLACK	1
CONTROL	N038000306	BUTTON (6) BLACK	1
CONTROL	N038000307	BUTTON (7) BLACK	1
CONTROL	N038000308	BUTTON (8) BLACK	1
CONTROL	N038000309	BUTTON (9) BLACK	1
CONTROL	N038000310	BUTTON (10) BLACK	1
CONTROL	N038000311	BUTTON (+/-) black	1
CONTROL	N038000312	BUTTON (CLR) BLACK	1
CONTROL	N038000313	BUTTON ( ) BLACK	2
CONTROL	N038000314	BUTTON ( ) BLACK	2
CONTROL	N038000315	BUTTON ( ) BLACK (ABS)	2
CONTROL	N038000319	BUTTON (CANCEL) ABS	1
CONTROL	N038000320	BUTTON (ENTER) ABS	1
CONTROL	N044010501	ENCODER 36STEP 2BIT GRAY CODE OUT	1
CONTROL	N045010101	LED T1 RED GaAsP 60 $\mu$ .16 MCD @ 20MA	1
CONTROL	N045010501	LED T1-3/4 RED GaAsP	8
CONTROL	N235023601	LCP LED SPACER LH-3-6	1
CONTROL	N243010401	TACT S/W "ALPS" 418A SKHCAA	38
DISK DRIVE ASSY	N013030801	CABLE POWER FDD 4P 28Cm 2000R	1
DISK DRIVE ASSY	N013030901	CABLE DATA FDD 34P 32Cm 2000R	1
DISK DRIVE ASSY	N025323304	MACHINE SCREW BH M3X4 BLK	4
DISK DRIVE ASSY	N032028021	FDD/HDD MOUNTING BRACKET	1
DISK DRIVE ASSY	N215000601	FDD 3.5" DS HD 1" HIGH W/BLACK BEZEL	1
ENGINE&AUDIO SHIELD	N032024311	SUMIDA FILTER SHIELD (1TX100X100M/M)	1
ENGINE&AUDIO SHIELD	N039030603	TAPE (45X72M/M)	1
ENGINE (DIP)	N025323304	MACHINE SCREW BH M3X4 BLK	6
ENGINE (DIP)	N033100401	P.C.B;ENGINE K-2000/K2000R	1
ENGINE (DIP)	N041010302	CONN JUMPER.1SP 2 POS	2
ENGINE (DIP)	N041021005	JACK MIDI 5 PIN (PCB)	3
ENGINE (DIP)	N041021120	SOCKET IC .3W 20PIN	1

LOCATION	PART NO.	DESCRIPTION	QTY
ENGINE (DIP)	N041021122	SOCKET IC .3W 24 PIN	3
ENGINE (DIP)	N041021132	SOCKET IC .6W 32PIN	4
ENGINE (DIP)	N041030003	HEADER .1SP 3POS(22-03-2031)	2
ENGINE (DIP)	N041031220	CONN HEAD DUAL ROW .1SP 20P(057-020-153)	1
ENGINE (DIP)	N041031234	HEAD DUAL ROW .1SP SHROUD34P(057-034-153)	3
ENGINE (DIP)	N041031250	CONN HEAD DUAL ROW .1SP SHROUD 50P	1
ENGINE (DIP)	N041032425	CONN DB-25 PLASTIC SHORT R/A PCMT	1
ENGINE (DIP)	N041032564	CONN EUROCARD DIN B 64PIN FEMALE100-064-	1
ENGINE (DIP)	N041032848	CONN EUROCARD HALF-C FEMALE 48P	1
ENGINE (DIP)	N041032906	CONN HEADER .1SP DUAL ROW 6 PIN	1
ENGINE (DIP)	N041033208	SOCKET SIP .1SP 8 PIN	3
ENGINE (DIP)	N041033330	SOCKET SIMM 30 PIN DUAL .3 SP	2
ENGINE (DIP)	N041034004	HEADER 22-03-5045 .098SP 4PIN	1
ENGINE (DIP)	N051001202	RESNET BUSSED 120X7 SIP8(MSP08A-01-121G)	3
ENGINE (DIP)	N052002201	CAP ELECT 100UF 16V RAD	1
ENGINE (DIP)	N052002406	CAP ELECT 470UF 16V 20% .2 SP	1
ENGINE (DIP)	N053000401	DIODE (1N270)	2
ENGINE (DIP)	N053000701	DIODE 1N4001 DO-41	1
ENGINE (DIP)	N053000801	DIODE SWITCH (1N4148)	1
ENGINE (DIP)	N055002001	INDUCTOR (BLO2RN2-R62)	7
ENGINE (DIP)	N059010002	CRYSTAL 19.968MHZ	1
ENGINE (DIP)	N059010103	CRYSTAL 32.000MHz 3rd OT, SERIES	1
ENGINE (DIP)	N062005702	IC PAL GAL16V8-15LP	1
ENGINE (DIP)	N062005902	IC PAL GAL20V8-15LP	3
ENGINE (DIP)	N062200501	IC ROM-4MB(K2000)	2
ENGINE (DIP)	N063002301	IC OPTO COUPLER (PC-910)	1
ENGINE (DIP)	N263010501	IC TL SCSI 1285KC	1
ENGINE (SMD)	N051001001	RESNET BUS 10Kx15 SOP16 SOMC-1601-103J	3
ENGINE (SMD)	N051001002	RESNET BUSSED 4.7Kx15 SOP16	1
ENGINE (SMD)	N051101708	RES 56 5% THICK FILM 1206	4
ENGINE (SMD)	N051101714	RES CF 110 5% THICK FILM 1206	8
ENGINE (SMD)	N051101715	RES 120 5% THICK FILM 1206	1
ENGINE (SMD)	N051101724	RES CF 470 5% THICK FILM 1206	2
ENGINE (SMD)	N051101734	RES 1.5K 5% THICK FILM 1206	2
ENGINE (SMD)	N051101738	RES CF 2.2K 5% THICK FILM 1206	7
ENGINE (SMD)	N051101740	RES 2.7K 5% THICK FILM 1206	3
ENGINE (SMD)	N051101741	RES 3K 5% THICK FILM 1206	1
ENGINE (SMD)	N051101745	RES CF 4.7K 5% THICK FILM 1206	6
ENGINE (SMD)	N051101748	RES 6.2K 5% THICK FILM 1206	1
ENGINE (SMD)	N051101757	RES CF 10K 5% THICK FILM 1206	2
ENGINE (SMD)	N051101797	RES CF 10M 5% THICK FILM 1206	1
ENGINE (SMD)	N052007001	CAP CER 15pF 100V 5% NPO 1206	2
ENGINE (SMD)	N052007002	CAP CER 22pF 100V 5% NPO 1206	1
ENGINE (SMD)	N052007003	CAP CER 47pF 100V 5% NPO 1206	5
ENGINE (SMD)	N052007004	CAP CER 1000pF 100V 5% NPO 1206	13
ENGINE (SMD)	N052007101	CAP CER .1uF 50V 5% Z5U 1206	63
ENGINE (SMD)	N054000802	TRANS MMBT2222L SOT-23	1
ENGINE (SMD)	N061000202	IC LOGIC 74LS138 SOP	1

## SECTION 6

KURZWEIL K2000R  
PARTS LIST

K2000RP.WK1 12/23/92

LOCATION	PART NO.	DESCRIPTION	QTY
ENGINE (SMD)	N061001302	IC LOGIC 74LS04 SOP	1
ENGINE (SMD)	N061001502	IC LOGIC 74LS74A SOP	1
ENGINE (SMD)	N061001602	IC LOGIC 74LS32 SOP	2
ENGINE (SMD)	N061003002	IC LOGIC 74LS245 SOP	3
ENGINE (SMD)	N061010302	IC LOGIC 74HCU04 SOP	2
ENGINE (SMD)	N061018302	IC LOGIC 74HC08 SOP	3
ENGINE (SMD)	N061018402	IC LOGIC 74LS241 SOP	3
ENGINE (SMD)	N061018502	IC LOGIC 74F139 SOP	1
ENGINE (SMD)	N061018602	IC LOGIC 74F174 SOP	2
ENGINE (SMD)	N061018702	IC LOGIC 74LS174 SOP	1
ENGINE (SMD)	N251001102	RESISTOR NETWORK 120X15SOP SOMC1601-121	1
ENGINE (SMD)	N261017502	IC 74LS541	9
ENGINE (SMD)	N262001002	IC 68301	1
ENGINE (SMD)	N262100801	IC SRAM TC518128S	2
ENGINE (SMD)	N263010201	IC L53C80JC2 PLCC44	1
ENGINE (SMD)	N263010401	IC UPD72064	1
ENGINE (SMD)	N266000302	IC CUSTOM HOBBS CHIP	2
ENGINE (SMD)	N266000401	IC CUSTOM CALVIN CHIP	1
ENGINE (SMD)	N283010601	MASK ROM 1A	1
ENGINE (SMD)	N283010701	MASK ROM 1B	1
ENGINE (SMD)	N283010801	MASK ROM 2A	1
ENGINE (SMD)	N283010901	MASK ROM 2B	1
ENGINE (SMD)	N283011001	MASK ROM 3A	1
ENGINE (SMD)	N283011101	MASK ROM 3B	1
ENGINE (SMD)	N283011201	MASK ROM 4A	1
ENGINE (SMD)	N283011301	MASK ROM 4B	1
LCD ASSY	N013030001	CABLE LCD 20P 48cm 2000R	1
LCD ASSY	N013030301	CABLE LCD BACKLIGHT 4P K2000R	1
LCD ASSY	N025323306	MACHINE SCREW BH M3X6 BLK	4
LCD ASSY	N027112100	FLAT WASHER 3.3X6.5X0.5 BLK	4
LCD ASSY	N092000504	LCD (0.05X100X200)	0.01
LCD ASSY	N245010301	DISPLAY LCD 240X64 W/CTR LM24014H	1
LCD ASSY	N245010402	BACKLIGHT EL 136X40MM LFOB09	1
PHONE/VOLUME BOARD	N013030101	CABLE VOLUME TO AUDIO 5P 20cm 2000R	1
PHONE/VOLUME BOARD	N013031001	CABLE HEADPHONE TO AUDIO 3P 22cm 2000R	1
PHONE/VOLUME BOARD	N033101005	PCB FAB VOLUME & HEADPHONE 2000R	1
PHONE/VOLUME BOARD	N051101605	POT ROTARY VOLUME (10K ) CPSG-1604	1
PHONE/VOLUME BOARD	N052005402	CAP CERMONO 470PF 100V 10% X7R AX	2
PHONE/VOLUME BOARD	N055002201	CHOKE COIL TRIPLE TORROID DLF3000	1
PHONE/VOLUME BOARD	N232028332	VOLUME KNOB (P/N;BPLG-10T) 2000R	1
PHONE/VOLUME BOARD	N241034501	JACK 1/4"	1
POWER ENTRY MODULE	N013040001	CRIMP TERMINAL HOUSING (10-63-3054)	3
POWER ENTRY MODULE	N032028211	AC ENTRY PLATE	1
POWER ENTRY MODULE	N033101006	PCB FAB VOLTAGE SELECTOR BOARD 2000R	1
POWER ENTRY MODULE	N041030605	HEADER 10-31-1058 1ROW	4
POWER ENTRY MODULE	N041032202	HEADER 10-32-1021 .2SP 1ROW	1
POWER ENTRY MODULE	N042005020	GROUNDING WIRE RING LUG 100MM	1
POWER ENTRY MODULE	N043002106	FUSE SLO-BLO 5X20MM 250V 1.25A	2

LOCATION	PART NO.	DESCRIPTION	QTY
POWER ENTRY MODULE	N241033701	POWER MODULE (Corcom:3EGG-2) 2000R	1
POWER ENTRY MODULE	N013040001	CRIMP TERMINAL HOUSING (10-63-3054)	3
POWER ENTRY MODULE	N032028211	AC ENTRY PLATE	1
POWER ENTRY MODULE	N033101006	PCB FAB VOLTAGE SELECTOR BOARD 2000R	1
POWER ENTRY MODULE	N041030605	HEADER 10-31-1058 1ROW	4
POWER ENTRY MODULE	N041032202	HEADER 10-32-1021 .2SP 1ROW	1
POWER ENTRY MODULE	N042005020	GROUNDING WIRE RING LUG 100MM	1
POWER ENTRY MODULE	N043002107	FUSE T TYPE 5X20MM 250V 0.63A	2
POWER ENTRY MODULE	N241033701	POWER MODULE (Corcom:3EGG-2) 2000R	1
POWER SWITCH	N013031301	CABLE POWER S/W 2P W/HOUSING 10-01-3028	1
POWER SWITCH	N043020101	POWER SWITCH ? K2000R	1
TRANSFORMER ASSY	N013030401	CABLE TRANS W/HOUSING 10-63-3054	1
TRANSFORMER ASSY	N013030402	CABLE TRANS 2000R	1
TRANSFORMER ASSY	N015000502	TRANSFORMER K2000R	1