

Service Manual

PIONEER®
The Art of Entertainment

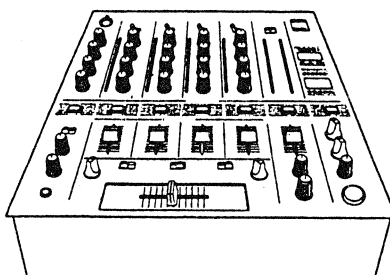

ORDER NO.
RRV1405

DJ MIXER

DJM-500

THIS MANUAL IS APPLICABLE TO THE FOLLOWING MODEL(S) AND TYPE(S).

Type	Model	Power Requirement	The voltage can be converted by the following method.
	DJM-500		
KUC	○	AC120V	_____
RELM	○	AC110-120V/220-240V	With the voltage selector

CONTENTS

1. SAFETY INFORMATION	2	5. PCB PARTS LIST	41
2. EXPLODED VIEWS, PACKING AND PARTS LIST	3	6. IC INFORMATION	46
3. BLOCK DIAGRAM	7	7. DISASSEMBLY	53
4. SCHEMATIC AND PCB CONNECTION DIAGRAMS	10	8. PANEL FACILITIES	55
		9. SPECIFICATIONS	59

PIONEER ELECTRONIC CORPORATION 4-1, Meguro 1-Chome, Meguro-ku, Tokyo 153, Japan
PIONEER ELECTRONICS SERVICE INC. P.O. Box 1760, Long Beach, CA 90801-1760, U.S.A.
PIONEER ELECTRONIC [EUROPE] N.V. Haven 1087 Keetberglaan 1, 9120 Melsele, Belgium
PIONEER ELECTRONICS ASIACENTRE PTE. LTD. 501 Orchard Road, #10-00 Lane Crawford Place, Singapore 0923

© PIONEER ELECTRONIC CORPORATION 1995

T-DFY NOV. 1995

1. SAFETY INFORMATION

This service manual is intended for qualified service technicians; it is not meant for the casual do-it-yourselfer. Qualified technicians have the necessary test equipment and tools, and have been trained to properly and safely repair complex products such as those covered by this manual. Improperly performed repairs can adversely affect the safety and reliability of the product and may void the warranty. If you are not qualified to perform the repair of this product properly and safely, you should not risk trying to do so and refer the repair to a qualified service technician.

WARNING

Lead in solder used in this product is listed by the California Health and Welfare agency as a known reproductive toxicant which may cause birth defects or other reproductive harm (California Health & Safety Code, Section 25249.5). When servicing or handling circuit boards and other components which contain lead in solder, avoid unprotected skin contact with the solder. Also, when soldering do not inhale any smoke or fumes produced.



NOTICE

(FOR CANADIAN MODEL ONLY)

Fuse symbols  (fast operating fuse) and/or  (slow operating fuse) on PCB indicate that replacement parts must be of identical designation.

REMARQUE

(POUR MODÈLE CANADIEN SEULEMENT)

Les symboles de fusible  (fusible de type rapide) et/ou  (fusible de type lent) sur CCI indiquent que les pièces de remplacement doivent avoir la même désignation.

(FOR USA MODEL ONLY)

1. SAFETY PRECAUTIONS

The following check should be performed for the continued protection of the customer and service technician.

LEAKAGE CURRENT CHECK

Measure leakage current to a known earth ground (water pipe, conduit, etc.) by connecting a leakage current tester such as Simpson Model 229-2 or equivalent between the earth ground and all exposed metal parts of the appliance (input/output terminals, screwheads, metal overlays, control shaft, etc.). Plug the AC line cord of the appliance directly into a 120V AC 60 Hz outlet and turn the AC power switch on. Any current measured must not exceed 0.5 mA.

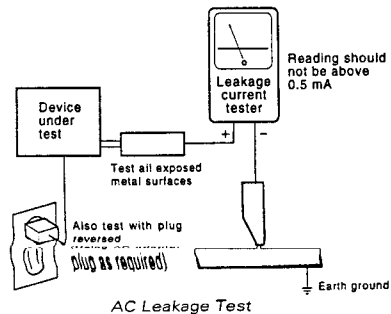

ANY MEASUREMENTS NOT WITHIN THE LIMITS OUTLINED ABOVE ARE INDICATIVE OF A POTENTIAL SHOCK HAZARD AND MUST BE CORRECTED BEFORE RETURNING THE APPLIANCE TO THE CUSTOMER.

2. PRODUCT SAFETY NOTICE

Many electrical and mechanical parts in the appliance have special safety related characteristics. These are often not evident from visual inspection nor the protection afforded by them necessarily can be obtained by using replacement components rated for voltage, wattage, etc. Replacement parts which have these special safety characteristics are identified in this Service Manual.

Electrical components having such features are identified by marking with a  on the schematics and on the parts list in this Service Manual.

The use of a substitute replacement component which does not have the same safety characteristics as the PIONEER recommended replacement one, shown in the parts list in this Service Manual, may create shock, fire, or other hazards.

Product Safety is continuously under review and new instructions are issued from time to time. For the latest information, always consult the current PIONEER Service Manual. A subscription to, or additional copies of, PIONEER Service Manual may be obtained at a nominal charge from PIONEER.

2. EXPLODED VIEWS, PACKING AND PARTS LIST

NOTES:

- Parts marked by "NSP" are generally unavailable because they are not in our Master Spare Parts List.
- The  mark found on some component parts indicates the importance of the safety factor of the part. Therefore, when replacing, be sure to use parts of identical designation.
- Parts marked by "⊙" are not always kept in stock. Their delivery time may be longer than usual or they may be unavailable.

2.1 PACKING

Mark	No.	Description	Parts No.	Mark	No.	Description	Parts No.
	1		11	PACKING CASE (KUC type)	DHG1683	
	2		11	PACKING CASE (RELM type)	DHG1682	
	3		12	SHEET	RHX1006	
	4		NSP	13 FOLLOW UP CARD (KUC type only)	DRY1032	
	5	AC POWER CORD (KUC type)	DDG1071	NSP	14 VINYL BAG (KUC type only)	DHL1011	
	5	AC POWER CORD (RELM type)	ADG1127	NSP	15 CAUTION CARD (220V) (RELM type only)	ARR7008	
	6	OPERATING INSTRUCTIONS (English) (KUC type)	DRB1192		16 INSTRUCTION MANUAL	DRM1187	
	6	OPERATING INSTRUCTIONS (English/French/German/Italian/Dutch/Swedish/Spanish/Chinese) (RELM type)	DRB1191				
	7					
	8	POLYETHYLENE BAG (0.03X230X340)	Z21-038				
	9	PAD L	DHA1350				
	10	PAD R	DHA1354				

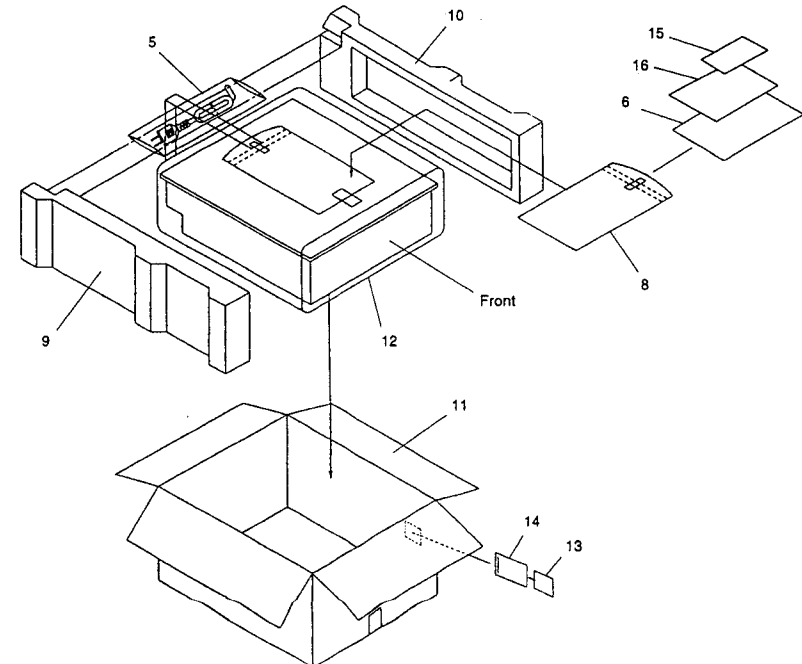

DJM-500

2.2 EXTERIOR

Mark	No.	Description	Parts No.	Mark	No.	Description	Parts No.
NSP	1	EFFECT VR ASSY	DWG1472	59	DISPLAY PANEL B	DAH1796	
NSP	2	FADER VR ASSY (MAIN)	DWG1474	60	CONTROL PANEL	DNB1066	
NSP	3	FADER VR ASSY (CH1)	DWG1475				
NSP	4	FADER VR ASSY (CH2)	DWG1476	61	LOOP KNOB	DNK2943	
NSP	5	FADER VR ASSY (CH2)	DWG1477	62	FOOT ASSY	REC-434	
				63	ROTARY VR KNOB G	DAA1133	
NSP	6	FADER VR ASSY (CH2)	DWG1478	64	ROTARY SW KNOB	DAA1134	
	7	DSP ASSY	DWZ1055	65	ROTARY VR KNOB DG	DAA1135	
	8	TERMINAL ASSY	DWZ1056				
	9	VR ASSY	DWG1471	66	ROTARY VR KNOB B	DAA1136	
NSP	10	PHONE JACK ASSY	DWZ1057	67	ROTARY VR KNOB GY	DAA1139	
				68	ROTARY VR KNOB GG	DAA1140	
NSP	11	MIC JACK ASSY	DWZ1066	69	FADER KNOB	DAC1846	
NSP	12	C. F. ASSY	DWG1473	70	POWER KNOB	DAC1847	
NSP	13	VOLTAGE SELECT ASSY	DWR1241				
	14	POWER SUP. ASSY	DWR1242	71	TACT KNOB	DAC1848	
NSP	15	POWER TRANS ASSY	DWR1243	72	POWER KNOB GUIDE	DNK3207	
				73	TACT KNOB GUIDE	DNK3208	
	16	SW COVER (RELM type only)	DEC1984	74	EFFECT SW PACKING	DED1110	
NSP	17	POWER SW ASSY	DWR1245	NSP	75	CLIP	AEC-036
NSP	18	REG. ASSY	DWR1246				
	19	7SEG. ASSY	DWZ1058	76	PC SUPPORT	DEC1773	
NSP	20	BAL. OUT ASSY	DWZ1059	77	SHEET (KUC type only)	DEC1939	
				78	SPACER	DEC1649	
	21	PHONE ASSY	DWZ1060	NSP	79	COLLAR	DEC1953
NSP	22	CH1 METER ASSY	DWZ1061	80	BUSH	DEC1957	
NSP	23	CH2 METER ASSY	DWZ1062				
NSP	24	CH3 METER ASSY	DWZ1063	81	SCREW	DBA1044	
NSP	25	CH4 METER ASSY	DWZ1064	NSP	82	PC SUPPORT	VEC1235
				83	GUARD	DEC1964	
	26	MASTER METER ASSY	DWZ1065	84	GUARD TAPE	DED1113	
	27	TERMINAL SCREW	AKE-031	NSP	85	PCB HOLDER	PNW1706
	28	AC INLET ASSY (3P) (KUC type)	DKP3238				
	28	AC INLET ASSY (3P) (RELM type)	DKP3237	NSP	86	PC SUPPORT	VEC1749
	29	POWER TRANSFORMER	DTT1130	87	WASHER	DDE1010	
	30	FUSE (T800mA, FU2)	REK-099	88	SCREW	AMZ26P040FMC	
				89	SCREW	AMZ30P040FMC	
	31	FUSE (1.25A, FU1)	VEK1016	90	SCREW	BBZ30P060FMC	
NSP	32	PCB SPACER (30)	DEC1389				
	33	BOARD SPACER	DEC1955	91	SCREW	BBZ30P060FZK	
NSP	34	PCB MOULD	AMR1525	92	SCREW	BBZ30P100FZK	
	35	LABEL	DRW1739	93	SCREW	BBZ30P140FMC	
				94	SCREW	BBZ30P180FMC	
	36	FL SPACER	AEB7047	95	SCREW	BBZ40P060FMC	
	37	EDGE GUARD	DEC1944				
	38	NET A	DED1108	96	SCREW	BMZ40P060FMC	
NSP	39	CAUTION LABEL (G)	VRW-548	97	SCREW	BPZ30P080FZK	
NSP	40	CHASSIS (KUC type)	DNA1198	98	SCREW	CBZ30P080FZK	
NSP	40	CHASSIS (RELM type)	DNA1196	99	NUT	NKX2FUC	
				100	SCREW	PMH26P040FMC	
NSP	41	PANEL STAY	DND1192				
	42	SLIDER PLATE	DNF1518	NSP	101	SCREW	PPZ30P050FMC
	43	SW PLATE	DNF1519	102	CAUTION LABEL (KUC type only)	AAX-361	
	44	EARTH PLATE	DNF1520	103	EARTH LEAD (KUC type only)	DDX1157	
	45	SHIELD PLATE	DNH2117	104	CAPACITOR COVER (RELM type only)	REC-150	
				105	GROUND PLATE	ANK1074	
	46	CABLE COVER	DNH2139				
	47	G5 LABEL (KUC type only)	ORW1069	106	SHORT PIN PLUG	AKM-050	
NSP	48	PCB SUPPORT	REC1248	107	SPACER (WASHER)	DEC1982	
NSP	49	PCB SUPPORT	VEC1508	108	SPACER	DEB1327	
	50	SNAP PLATE	VNE1102	109	PVC SHEET A	DEC1979	
				110	PVC SHEET B	DEC1980	
	51	LEVER SW PACKING	DED1098				
	52	FADER PACKING A	DED1099	111	PVC SHEET C	DEC1981	
	53	FADER PACKING B	DED1100	112	PCB TAPE	DED1115	
	54	SLIDE SW PACKING	DED1106	113	ACETATE TAPE(G)	REH1010	
	55	TACT SW PACKING	DED1114	NSP	114	PC SUPPORT	VEC1749
				115	SCREW	BBZ30P040FMC	
	56	CAUTION LABEL (KUC type only)	DRW1728	NSP	116	CORD CLAMPER	RNE-513
	57	DISPLAY PANEL A	DAH1793				
	58	SLIDER PANEL	DAH1794				

NOTE : Screws adjacent to ▼ mark on the product are used for disassembly.

The parts with * marking is an attached parts of No. 9.

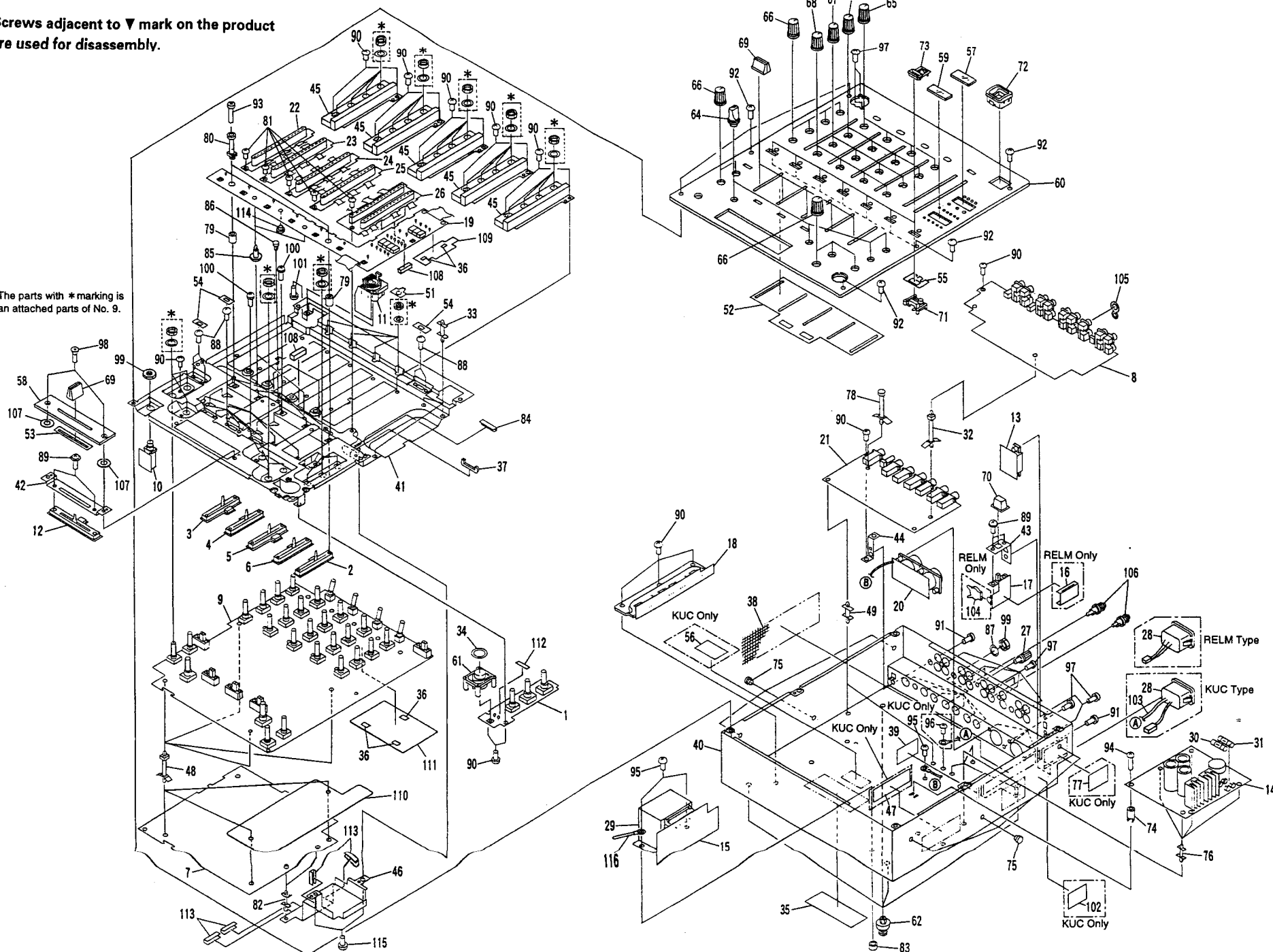

3. BLOCK DIAGRAM

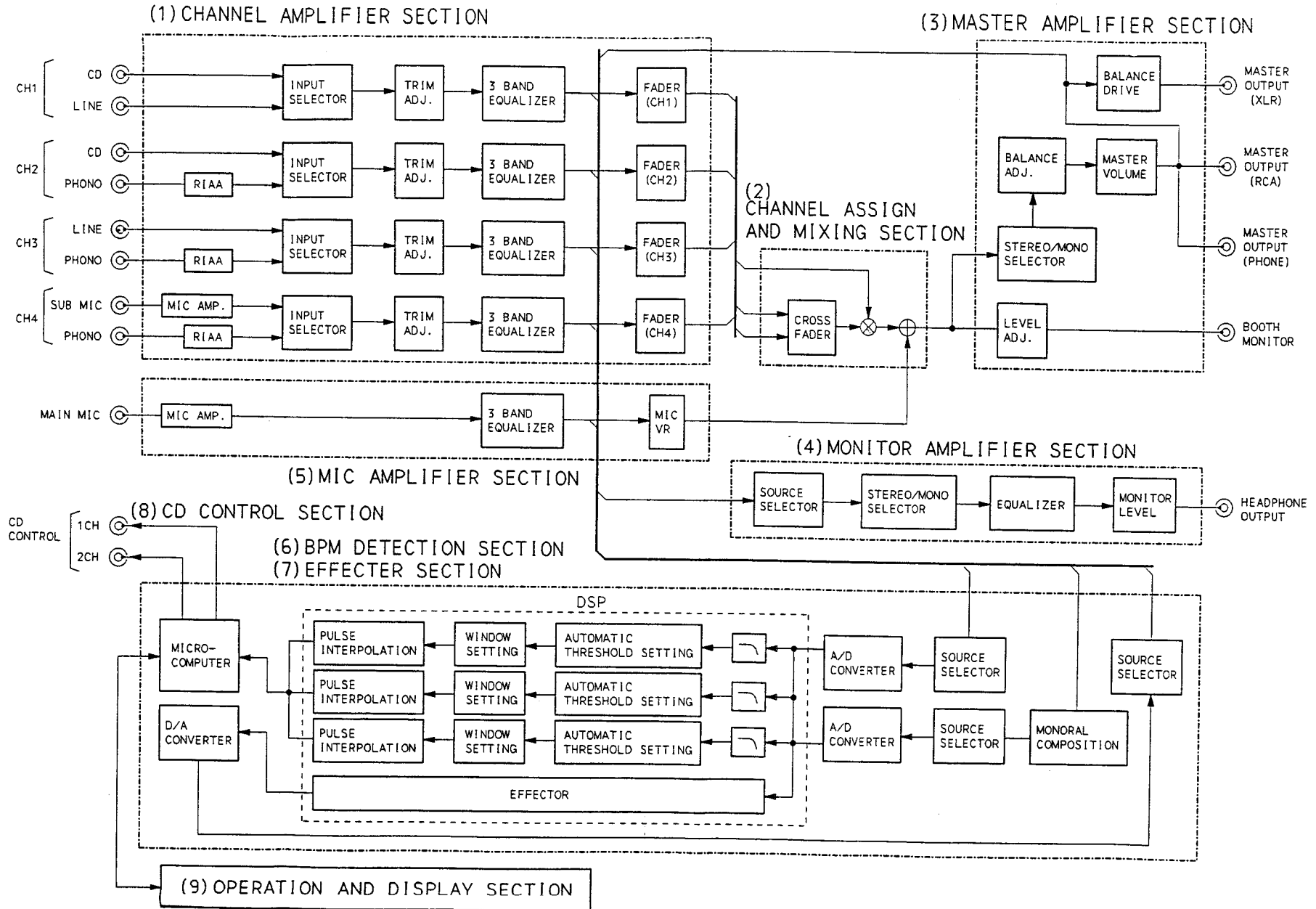

DJM-500

■ BLOCK DIAGRAM EXPLANATIONS

(1) Channel Amplifier Section

The input signal of each channel is sent to the mixing part. There are four channels, and each channel has input from two systems.

The respective channels are matched to the connected equipment, channel 1 is CD/LINE, channel 2 is CD/PHONO, channel 3 is LINE/PHONO, channel 4 is MIC (sub)/PHONO, and selection is made with the input selector switch.

Each channel is equipped with a 3-band equalizer permitting independent control of trim for control of the input signal level and fader volume for high, medium, and low range.

(2) Channel Assign and Mixing Section

The signal from the channel amplifier is selected with the C.F. assign switch and is sent to both ends of the cross-fader. The C.F./direct mixing switch is used to select mixing only with the source allotted to the cross-fader or mixing only with the cross-fader.

(3) Master Amplifier Section

The signal after mixing is processed.

The input signal passes balance adjustment and main volume adjustment and then is sent to the next stage.

(4) Monitor Amplifier Section

This is the source selection circuit for confirmation of the signal of each channel with headphones etc.

The input signal can be selected from channels 1 to 4, mike, effector, and master. For channels 1 to 4, the signal before each channel fader can be monitored, so that signal confirmation is possible in case of trim adjustment and master mixing. Also, an adjustable equalizer is installed for correspondence to cases where beat is difficult to hear with headphones.

(5) MIC Amplifier Section

There are two mike input systems, the phone type input (submike) at the rear panel and the Canon type input (main mike) at the control panel, and the main mike input is equipped with an independent equalizer for high, medium, and low range in addition to volume adjustment.

(6) BMP Detection Section

The BMP (Beats Per Minute, a factor indicating the speed of a title as the number of beats per minute) of the signal selected with the monitor select switch are detected, and the BMP value or the beat interval time is displayed.

The synchronization of the input signal by frequencies is detected, the BMP of the most stable signal are selected, and the data are processed by the microcomputer part. The detection modes are "real-time mode" with data display in real time and "average mode" with display of stable information for a certain time, and the microcomputer executes output according to the indication.

The beat timing also can be indicated to the beat monitor of the selected channel.

(7) Effector Section

Diverse effects can be realized with the built-in DSP (Digital Signal Processor).

The DSP operation can be selected with the effector function selection switch from pitch shifter, delay/flanger, pan/reverberation/echo.

The applicable channels are channels 1 to 4, mike, and master. For increased ease of use in combination with an external equalizer a SEND/RETURN terminal which can correspond to each channel is provided, and input level adjustment is possible.

(8) CD Control Section

When a CDJ-50/CDJ-500(G) is connected to channel 1 or 2, the CD player can be started from this unit.

In the same way, when CDJ-500 II is connected, stop (back cue) is possible in addition to CD player start. This is executed using the relay start function of CDJ-50/CDJ-500(G) and CDJ-500 II, and interlocked operation with channel fader and cross-fader also is possible.

(9) Operation and Display Section

The part in regard to display and operation of the built-in fader is executed by a microcomputer. BPM display and its mode switching, control of effect parameters and built-in fader, beat monitor, and level meter display, control, etc. are executed by an 8-bit microcomputer.

4. SCHEMATIC AND PCB CONNECTION DIAGRAMS

NOTE FOR SCHEMATIC DIAGRAMS Type 2A

1. When ordering service parts, be sure to refer to "PARTS LIST of EXPLODED VIEWS" or "PCB PARTS LIST".
2. Since these are basic circuits, some parts of them or the values of some components may be changed for improvement.
3. **RESISTORS:**
Unit: k: k Ω , M: M Ω , or Ω unless otherwise noted.
Rated power: 1/4W, 1/6W, 1/8W, 1/10W unless otherwise noted.
Tolerance: (F): $\pm 1\%$, (G): $\pm 2\%$, (K): $\pm 10\%$, (M): $\pm 20\%$ or $\pm 5\%$ unless otherwise noted.
4. **CAPACITORS:**
Unit: p: pF or μ F unless otherwise noted.
Ratings: capacitor (μ F)/ voltage (V) unless otherwise noted.
Rated voltage: 50V except for electrolytic capacitors.
5. **COILS:**
Unit: m: mH or μ H unless otherwise noted.
6. **VOLTAGE AND CURRENT:**
□ or - V :
The -14dBV (1kHz) signal on the CH1 (LINE) side is shown by the DC voltage (V) at the time of input.
↺ mA or ~ mA :
DC current at no input signal unless otherwise noted.
7. **OTHERS:**
 - ○ or ◉ : Adjusting point.
 - ◐ : Measurement point.
 - The Δ mark found on some component parts indicates the importance of the safety factor of the parts. Therefore, when replacing, be sure to use parts of identical designation.
8. **SCH-□ ON THE SCHEMATIC DIAGRAM:**
 - SCH-□ indicates the drawing number of the schematic diagram. (SCH stands for schematic diagram.)
9. **SWITCHES** (Underline indicates switch position):

EFFECT VR ASSY

- S171: CH. SELECTOR (1-2-3-4-MIC)
S174: EFFECT SELECTOR
(AUTO BPM-DELAY-ECHO-AUTO PAN
-FLANGER-REVERB-PITCH-SEND RETURN)

VR ASSY

- S1: MASTER STEREO-MONO
S2: MONITOR STEREO-MONO
S281: FADER START (CH1) ON-OFF
S282: ASSIGN A 1-2-3-4
S283: ASSIGN B 1-2-3-4
S284: CROSS FADER ON-OFF
S285: FADER START (CH2) ON-OFF
S401: INPUT SELECTOR (CH1) CD1-LINE1
S402: INPUT SELECTOR (CH2) CD2-PHONO1
S403: INPUT SELECTOR (CH3) LINE3-PHONO2
S404: INPUT SELECTOR (CH4) SUBMIC-PHONO3

7SEG. ASSY

- S652: MONITOR SELECTOR EFFECT
S653: MONITOR SELECTOR MASTER
S654: MONITOR SELECTOR CH4
S657: MONITOR SELECTOR MIC
S658: MONITOR SELECTOR CH1
S659: MONITOR SELECTOR CH2
S660: MONITOR SELECTOR CH3
S665: BPM REAL TIME-AVERAGE

VOLTAGE SELECT ASSY

- S902: VOLTAGE SELECTOR AC110-120V/220-240V

POWER SW ASSY

- S901: POWER SW ON-OFF

NOTE FOR PCB DIAGRAMS:

1. Part numbers in PCB diagrams match those in the schematic diagrams.
2. A comparison between the main parts of PCB and schematic diagrams is shown below.

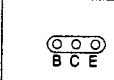
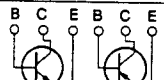
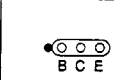
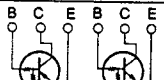
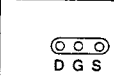
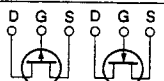
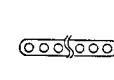
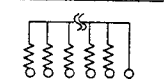
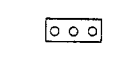
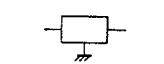
Symbol in PCB Diagrams	Symbol in Schematic Diagrams	Part Name
		Transistor
		Transistor with resistor
		Field effect transistor
		Resistor array
		3-terminal regulator

10. CONDITION TO BIND OF WAVEFORMS

Bind of VR

- VR131-VR134: FADER VR (CH1-CH4) MAX
VR401-VR404: TRIM VR (CH1-CH4) MAX
VR405-VR408: EQ HI VR (CH1-CH4) MIDDLE
VR409-VR412: EQ MID VR (CH1-CH4) MIDDLE
VR413-VR416: EQ LOW VR (CH1-CH4) MIDDLE
VR135: CROSS FADER A SIDE
VR2: MASTER BALANCE MIDDLE

Note: All the knob position (settings) for the oscilloscope in the schematic diagrams procedures are for when 10:1 probe is used.

4.1 OVERALL SCHEMATIC DIAGRAM

DJM-500

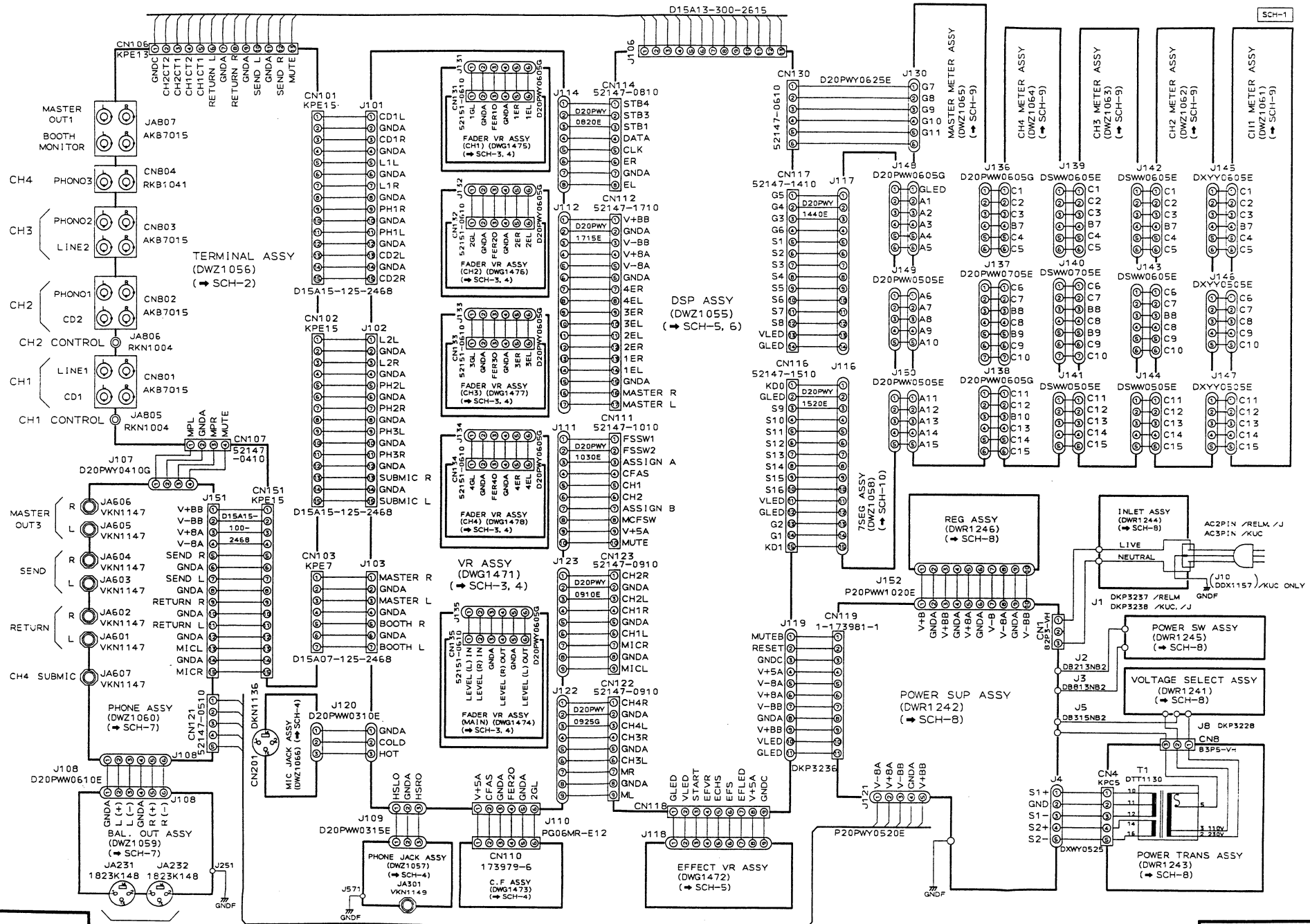

SCH-1

MASTER OUT2
OVERALL SCHEMATIC DIAGRAM
(総合結線図)

OVERALL SCHEMATIC DIAGRAM
(総合結線図)

SCH-1

The parts mounted on this PCB include all necessary parts for several destinations.
For further information for respective destinations, be sure to check with the schematic diagram.

このPCB面にマウントしている部品は複数の仕向地を含んでいます。
各仕向地の情報は、図説冊で確認するようにしてください。

• This diagram is viewed from the mounted parts side.

• この図は部品取付面側から見た図です。

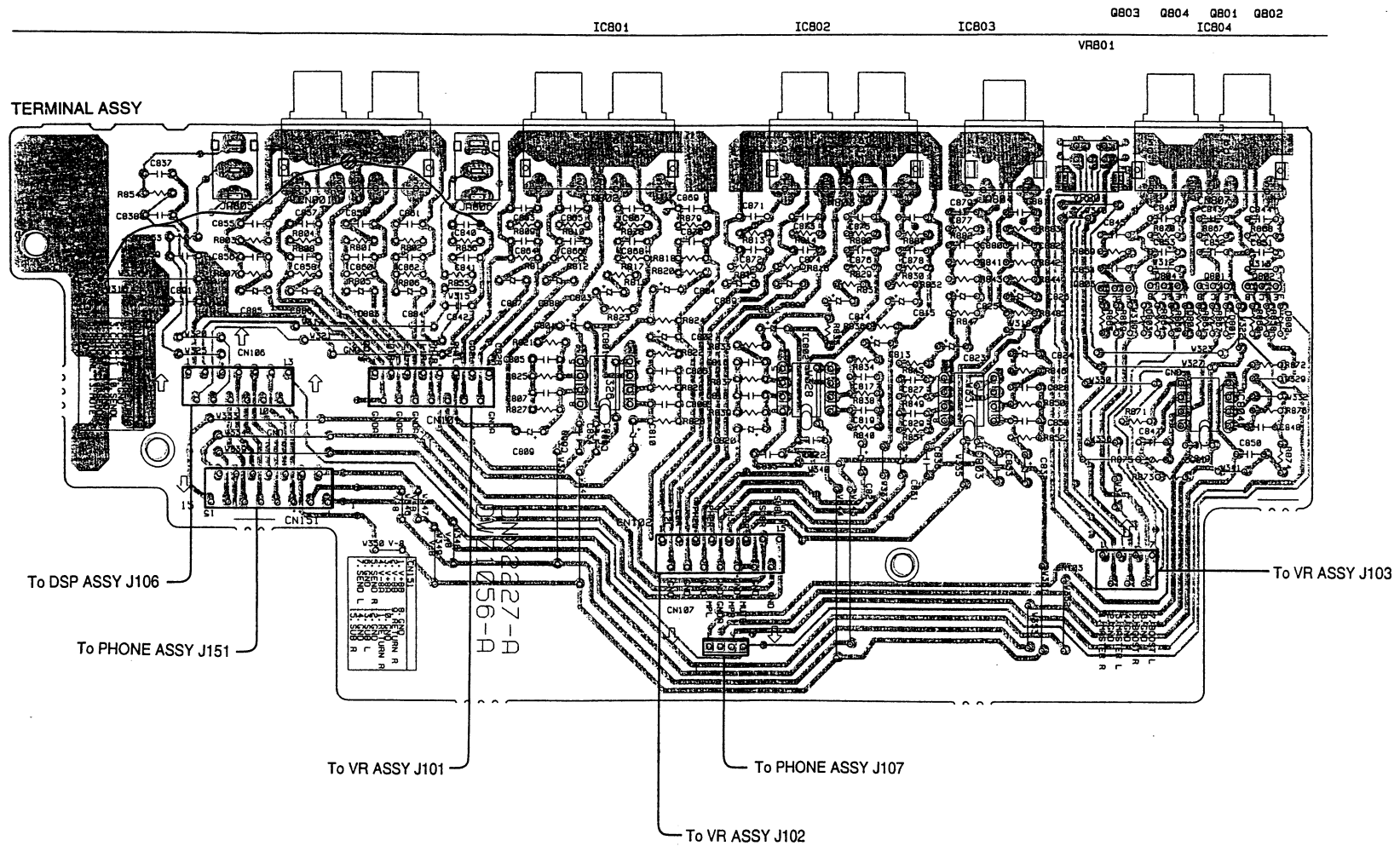

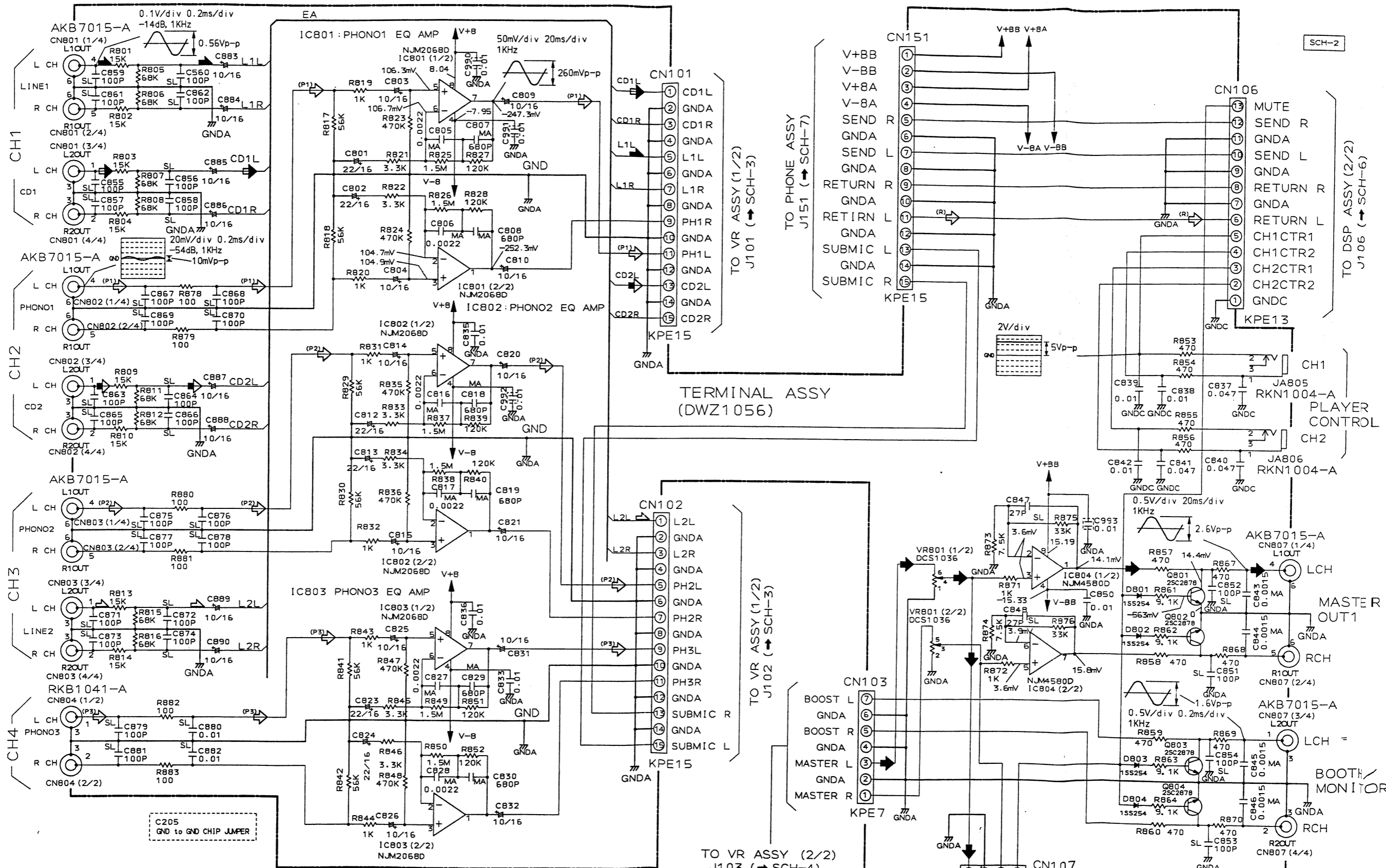

SIGNAL ROUTE

- ▶ AUDIO SIGNAL
- ◀ RETURN SIGNAL
- ◀ PHONO1 (CH2) SIGNAL
- ◀ PHONO2 (CH3) SIGNAL
- ◀ PHONO3 (CH4) SIGNAL
- ▶ CD (CH2) SIGNAL
- ▶ LINE1 (CH1) SIGNAL
- ▶ LINE2 (CH3) SIGNAL

SCH-2
TERMINAL ASSY

SCH-2
TERMINAL ASSY

DJM-500

4.3 VR ASSY, FADER VR ASSY (CH1), FADER VR ASSY (CH2), FADER VR ASSY (CH3), FADER VR ASSY (CH4), C. F. ASSY, PHONE JACK ASSY AND MIC JACK ASSY

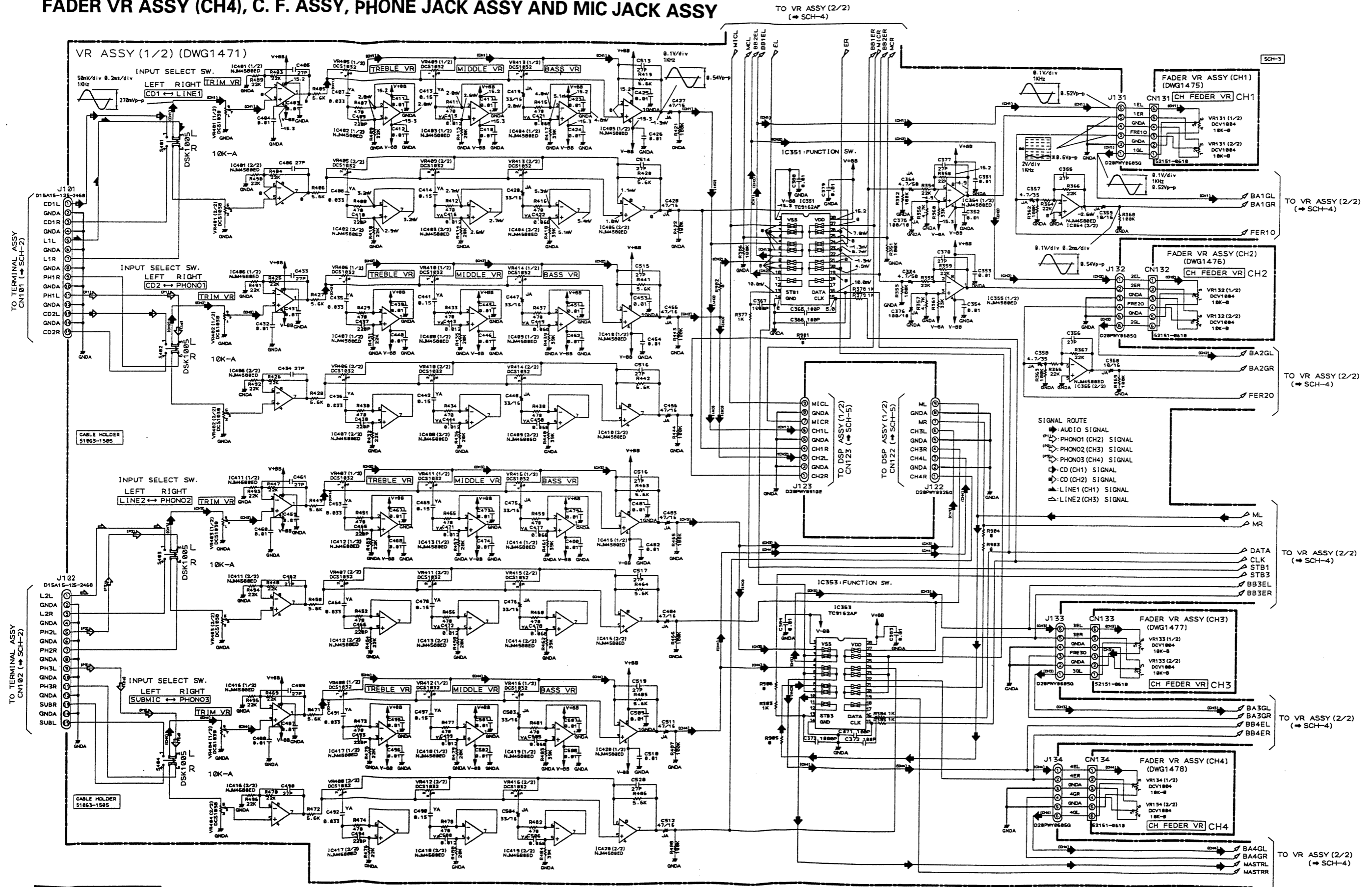

SCH-3 FADER VR ASSY (CH1), FADER VR ASSY (CH2), FADER VR ASSY (CH3), FADER VR ASSY (CH4), VR ASSY (1/2) **SCH-3**

The parts mounted on this PCB include all necessary parts for several destinations.
For further information for respective destinations, be sure to check with the schematic diagram.

このPCB面にマウントしている部品は複数の仕向けを含んでいます。
各仕向けの情報は、回路図で確認するようにしてください。

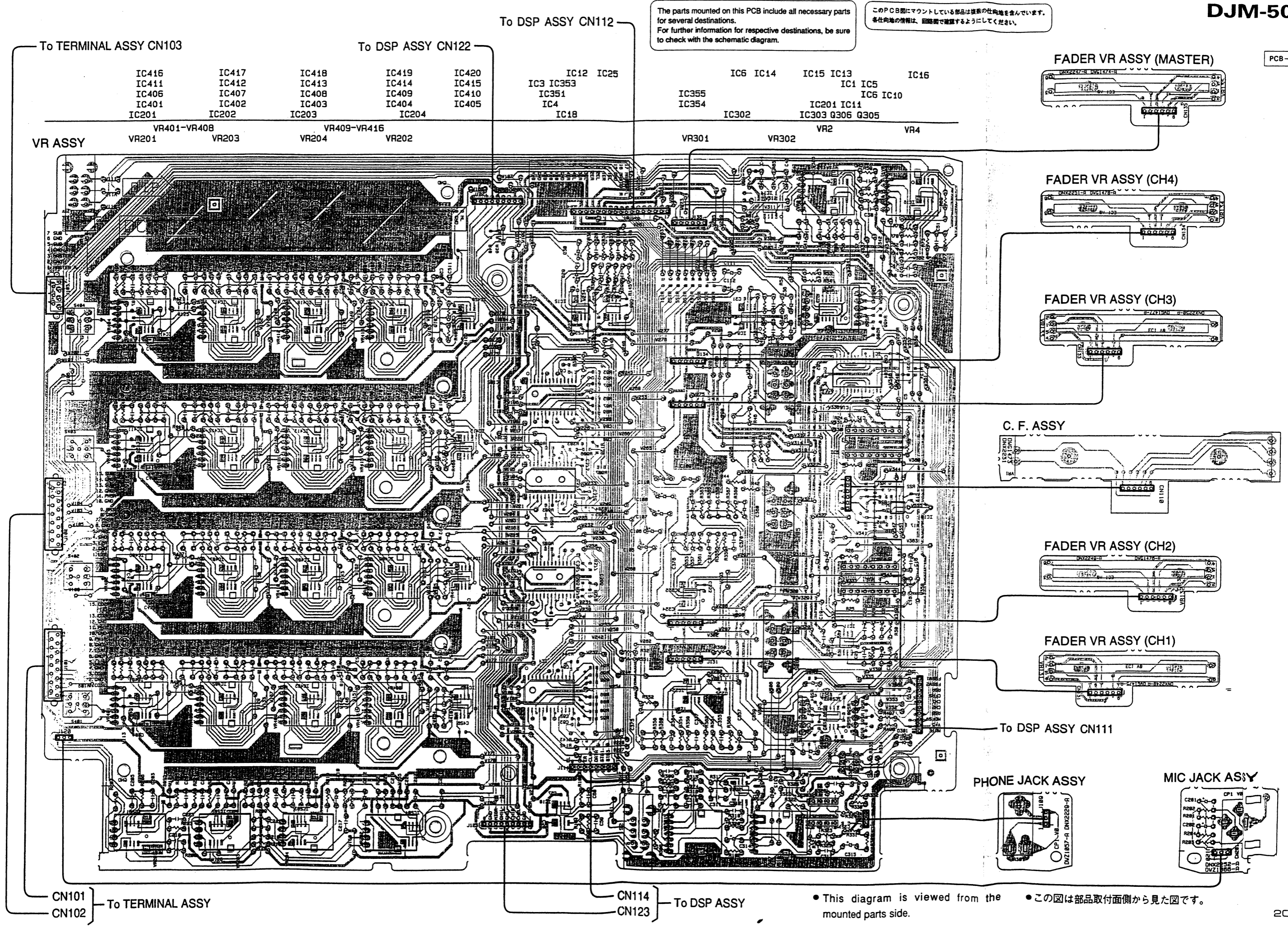

- | | | | | | | | | | | | |
|-------|-------|-------|-------|-------|-------|-------|-------|------|-------|------|------|
| IC416 | IC417 | IC418 | IC419 | IC420 | IC12 | IC25 | IC6 | IC14 | IC15 | IC13 | IC16 |
| IC411 | IC412 | IC413 | IC414 | IC415 | IC3 | IC353 | IC355 | | IC1 | IC5 | |
| IC406 | IC407 | IC408 | IC409 | IC410 | IC351 | | IC354 | | IC6 | IC10 | |
| IC401 | IC402 | IC403 | IC404 | IC405 | IC4 | | | | IC201 | IC11 | |
| IC201 | IC202 | IC203 | IC204 | | IC18 | | IC302 | | IC303 | Q306 | Q305 |

- | | | | | | |
|-------------|-------------|-------|-------|-----|-----|
| VR401-VR408 | VR409-VR416 | VR301 | VR302 | VR2 | VR4 |
| VR201 | VR203 | VR204 | VR202 | | |

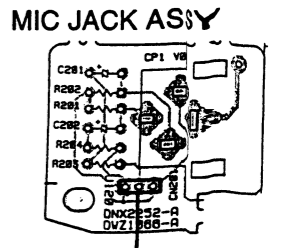
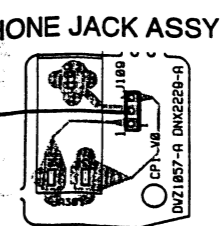
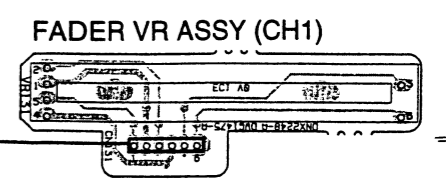
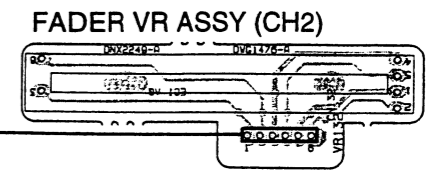
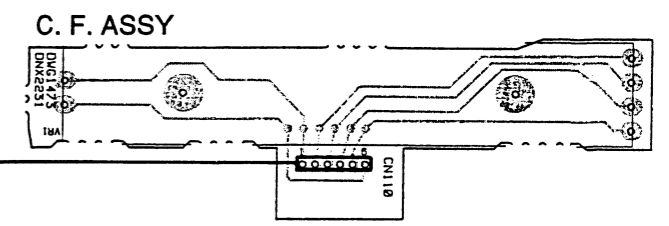
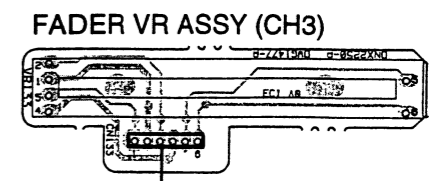
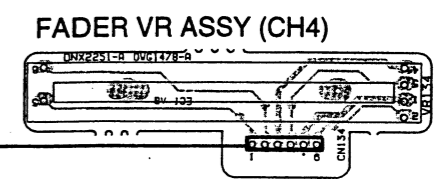
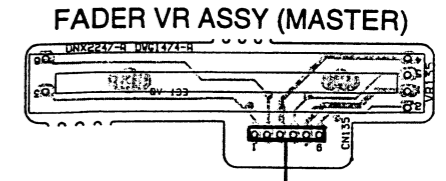

• This diagram is viewed from the mounted parts side. • この図は部品取付面側から見た図です。

TO VR ASSY (1/2) (SCH-3)

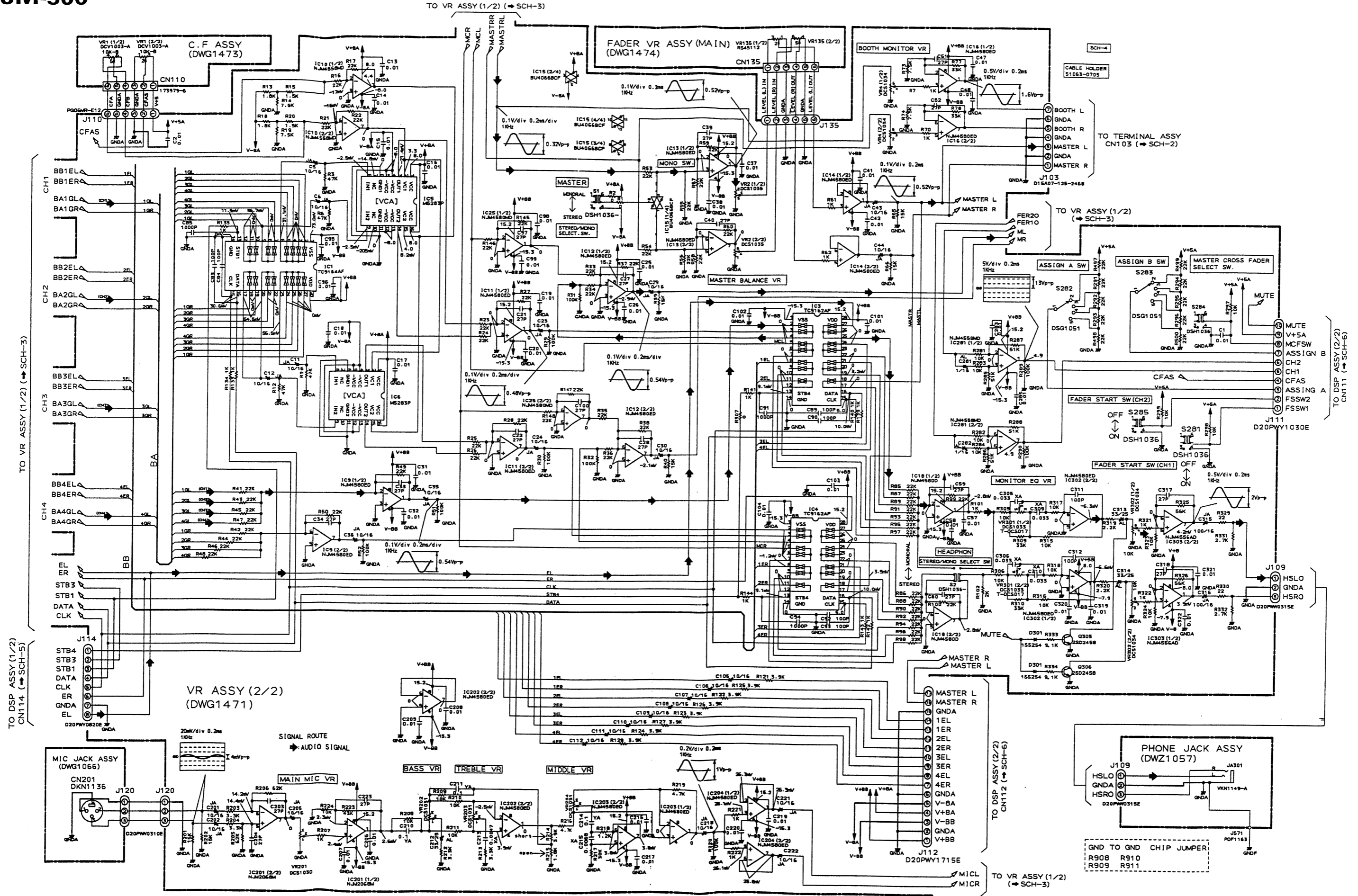

TO VR ASSY (1/2) (SCH-3)

TO DSP ASSY (1/2) CN114 (SCH-5)

VR ASSY (2/2) (DWG1471)

SCH-4

VR ASSY (2/2), C. F. ASSY, PHONE JACK ASSY, MIC JACK ASSY

VR ASSY (2/2), C. F. ASSY, PHONE JACK ASSY, MIC JACK ASSY

SCH-4

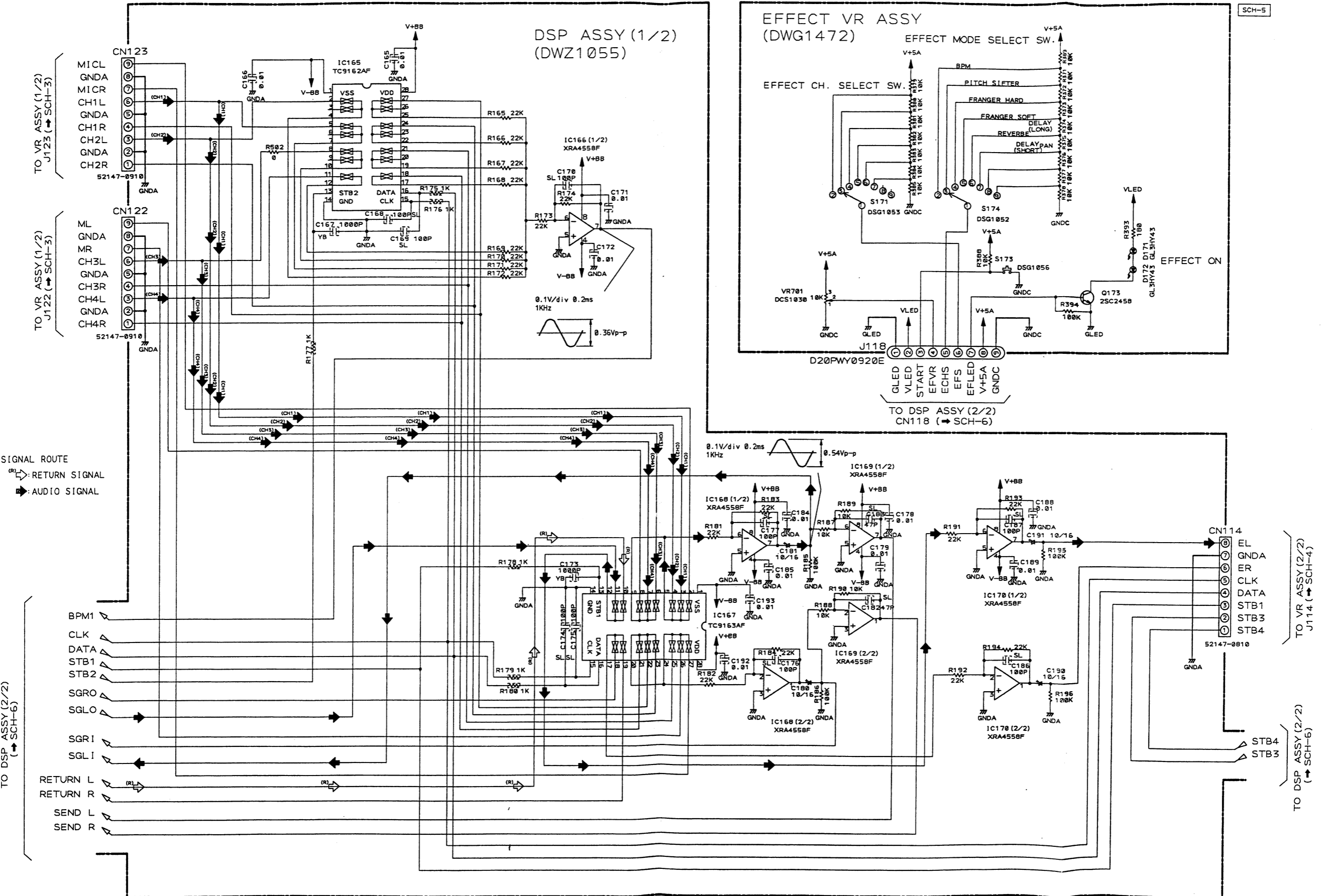

SIGNAL ROUTE
 (R) RETURN SIGNAL
 (A) AUDIO SIGNAL

SCH-5

DSP ASSY (1/2), EFFECT VR ASSY

SCH-5

DSP ASSY (1/2), EFFECT VR ASSY

The parts mounted on this PCB include all necessary parts for several destinations. For further information for respective destinations, be sure to check with the schematic diagram.

このPCB面にマウントしている部品は複数の仕向地を含んでいます。各仕向地の情報は、回路図で確認するようにしてください。

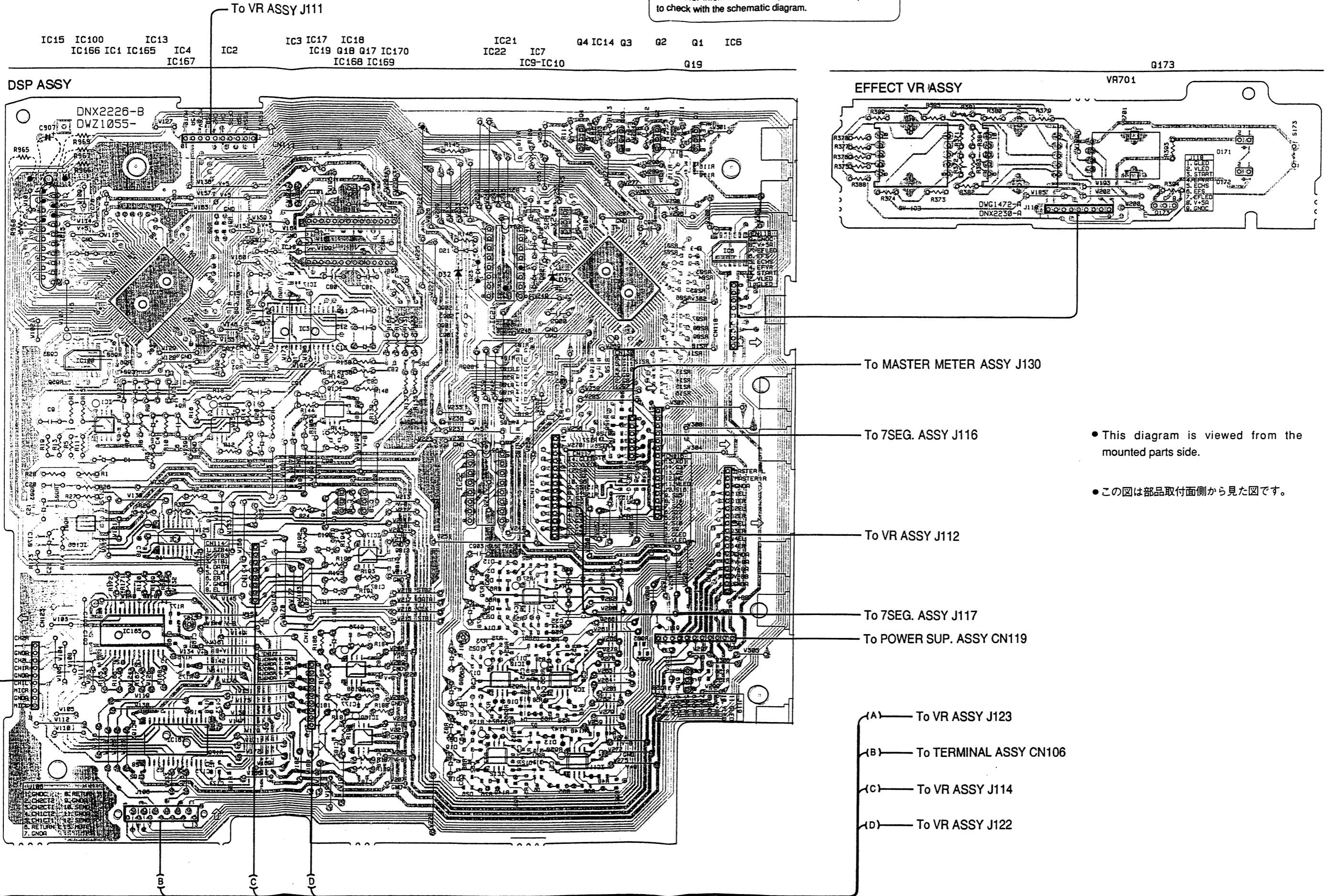

- This diagram is viewed from the mounted parts side.
- この図は部品取付面側から見た図です。

SCH-6

DSP ASSY (2/2)

SCH-6

DSP ASSY (2/2)

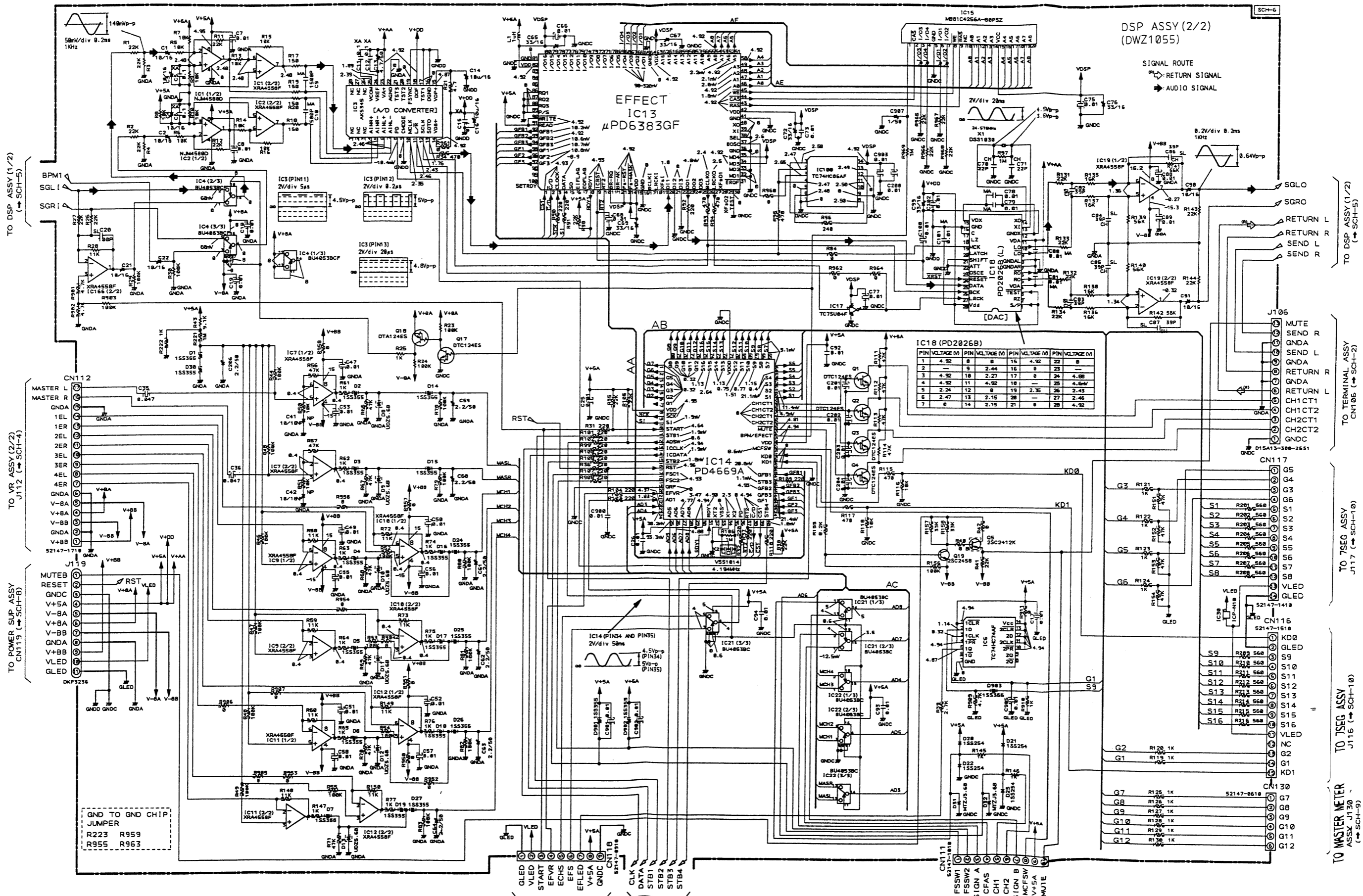

TO DSP ASSY (1/2) (SCH-5)

TO DSP ASSY (1/2) (SCH-5)

TO TERMINAL ASSY CN106 (SCH-2)

TO TSEG ASSY J117 (SCH-10)

TO TSEG ASSY J116 (SCH-10)

TO MASTER METER ASSY J130 (SCH-9)

TO VR ASSY (2/2) J112 (SCH-4)

TO POWER SUPP ASSY CN119 (SCH-B)

TO EFFECT VR ASSY J118 (SCH-5)

TO DSP ASSY (1/2) (SCH-5)

TO VR ASSY (2/2) J111 (SCH-4)

4.5 PHONE ASSY AND BAL. OUT ASSY

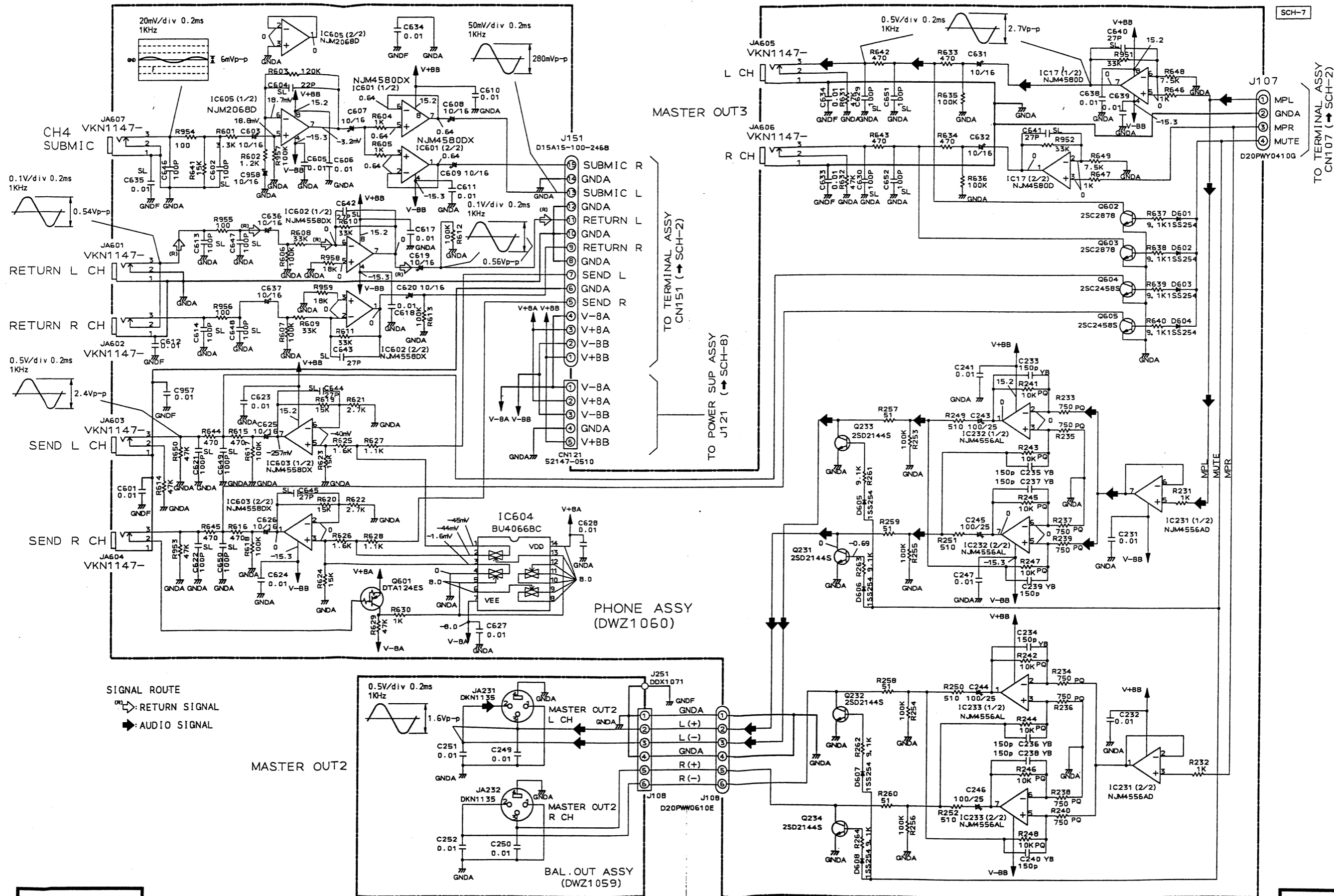

SCH-7

SCH-7

BAL. OUT ASSY

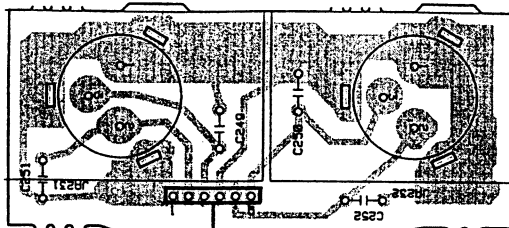

To TERMINAL ASSY CN151

To POWER SUP. ASSY J121

PHONE ASSY

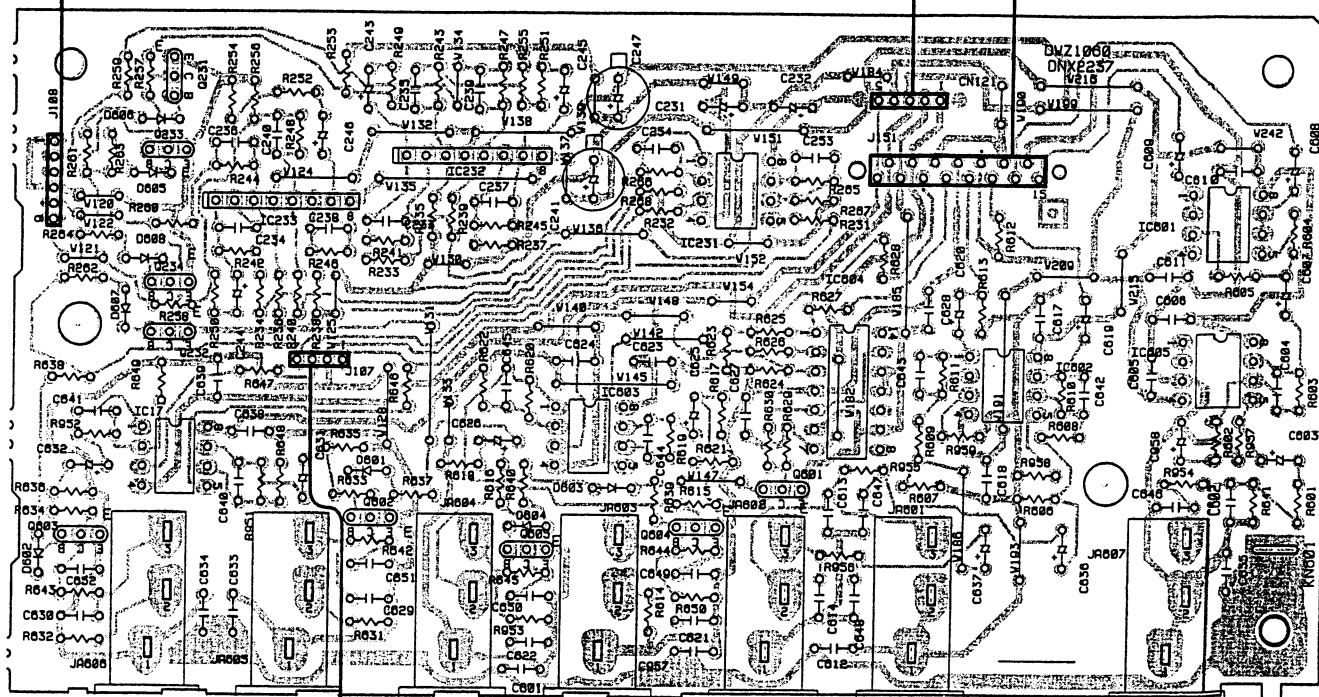

Q231-Q234 IC233
Q603 IC17

IC232 Q602 Q605 IC603 IC231 Q604 Q601 IC604

IC602 IC601 IC605

To TERMINAL ASSY CN107

The parts mounted on this PCB include all necessary parts for several destinations. For further information for respective destinations, be sure to check with the schematic diagram.

このPCB圖にマウントしている部品は複数の仕向地を含んでいます。各仕向地の情報は、回路図で確認するようにしてください。

- This diagram is viewed from the mounted parts side.
- この図は部品取付面側から見た図です。

DJM-500

4.6 POWER SUP. ASSY, POWER TRANS ASSY, INLET ASSY, VOLTAGE SEL ASSY, POWER SW ASSY AND REG. ASSY

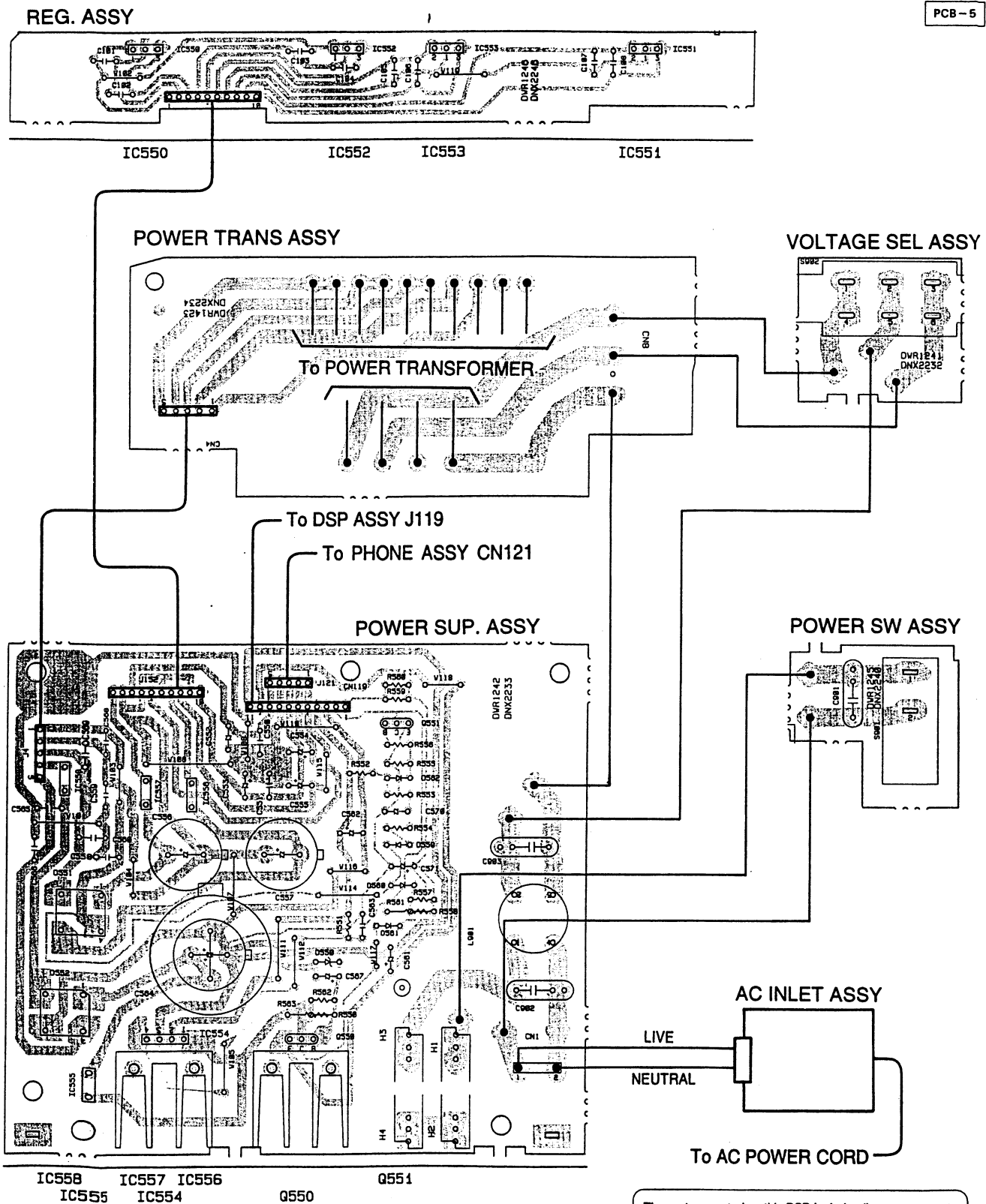

● This diagram is viewed from the mounted parts side.

● この図は部品取付面側から見た図です。

The parts mounted on this PCB include all necessary parts for several destinations. For further information for respective destinations, be sure to check with the schematic diagram.

このPCB面にマウントしている部品は複数の仕向地を含んでいます。各仕向地の情報は、回路図で確認するようにしてください。

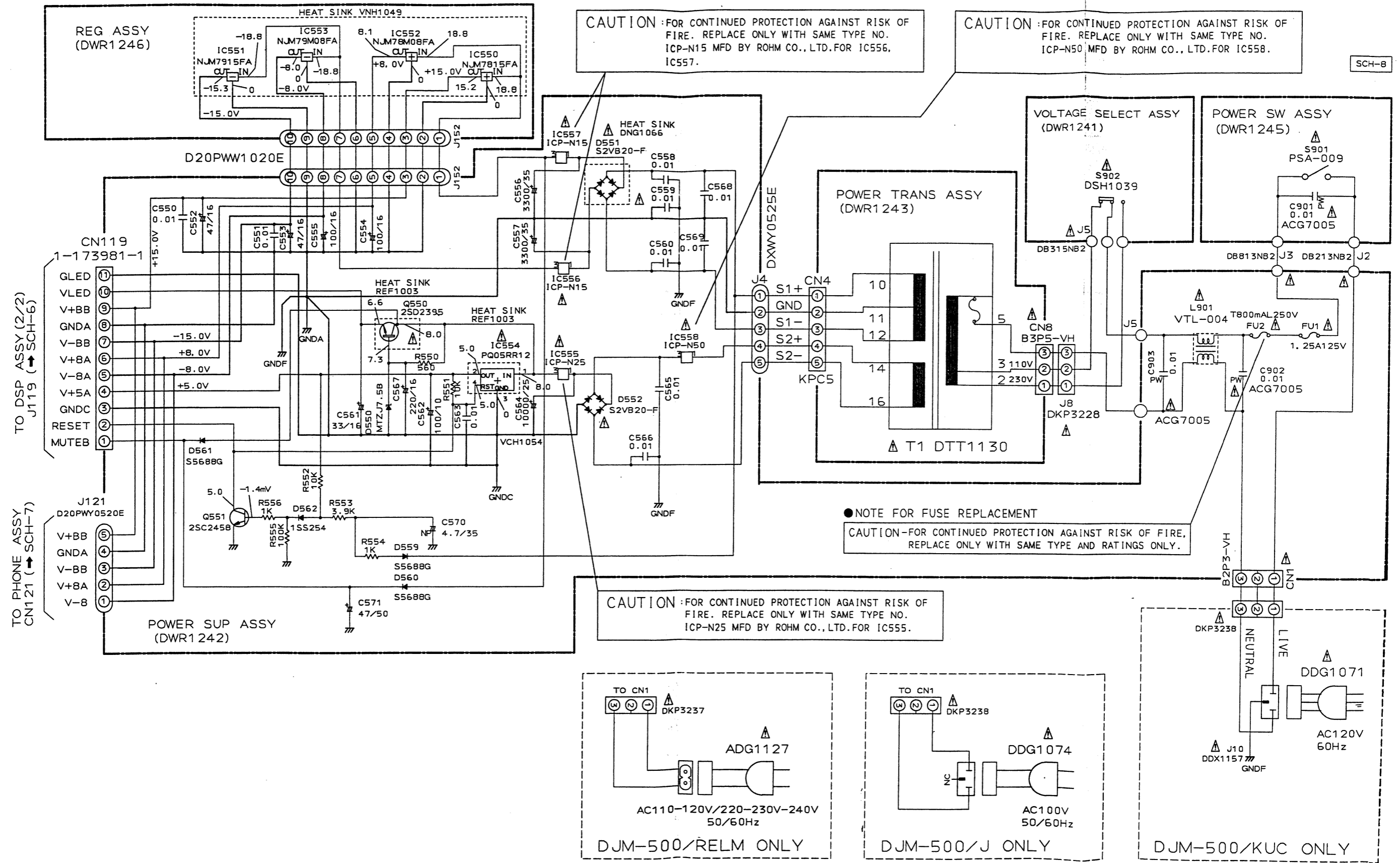

CAUTION: FOR CONTINUED PROTECTION AGAINST RISK OF FIRE. REPLACE ONLY WITH SAME TYPE NO. ICP-N15 MFD BY ROHM CO., LTD. FOR IC556, IC557.

CAUTION: FOR CONTINUED PROTECTION AGAINST RISK OF FIRE. REPLACE ONLY WITH SAME TYPE NO. ICP-N50 MFD BY ROHM CO., LTD. FOR IC555.

NOTE FOR FUSE REPLACEMENT
CAUTION-FOR CONTINUED PROTECTION AGAINST RISK OF FIRE, REPLACE ONLY WITH SAME TYPE AND RATINGS ONLY.

CAUTION: FOR CONTINUED PROTECTION AGAINST RISK OF FIRE. REPLACE ONLY WITH SAME TYPE NO. ICP-N25 MFD BY ROHM CO., LTD. FOR IC555.

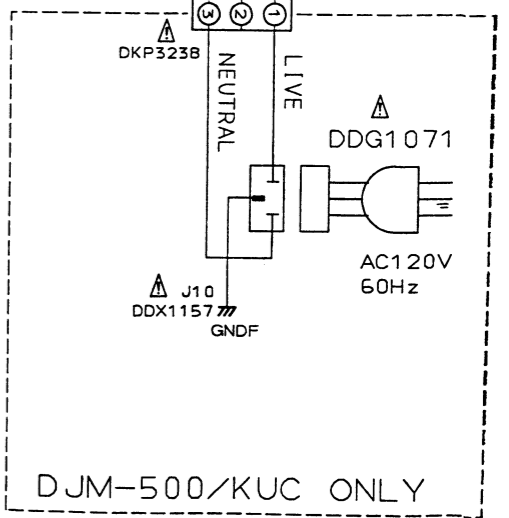
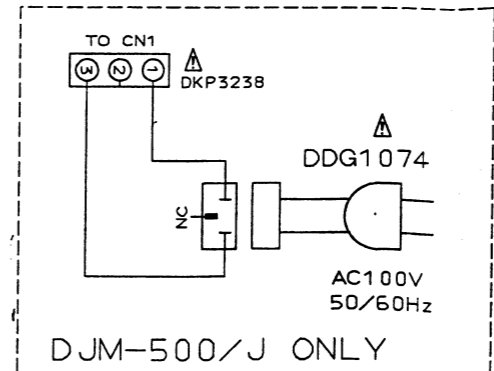
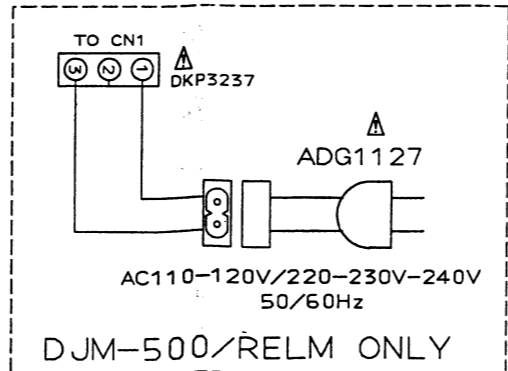

SCH-8 POWER SUP. ASSY, POWER TRANS ASSY, INLET ASSY, VOLTAGE SEL ASSY, POWER SW ASSY, REG. ASSY

SCH-8 POWER SUP. ASSY, POWER TRANS ASSY, INLET ASSY, VOLTAGE SEL ASSY, POWER SW ASSY, REG. ASSY

4.7 CH1 METER ASSY, CH2 METER ASSY, CH3 METER ASSY, CH4 METER ASSY, MASTER METER ASSY AND 7SEG. ASSY

SCH-9

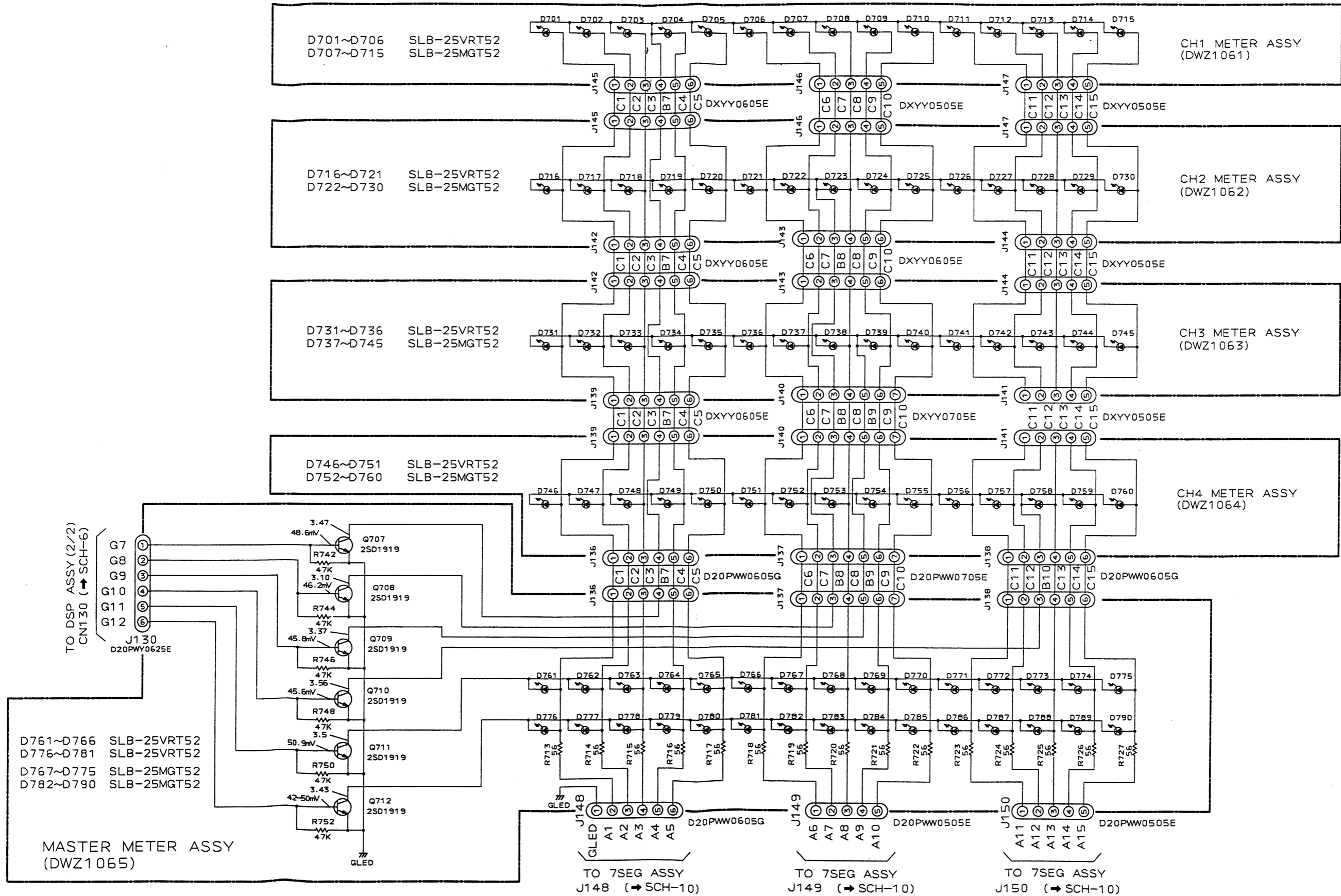

SCH-9

CH1 METER ASSY, CH2 METER ASSY,
CH3 METER ASSY, CH4 METER ASSY,
MASTER METER ASSY

CH1 METER ASSY, CH2 METER ASSY,
CH3 METER ASSY, CH4 METER ASSY,
MASTER METER ASSY

SCH-9

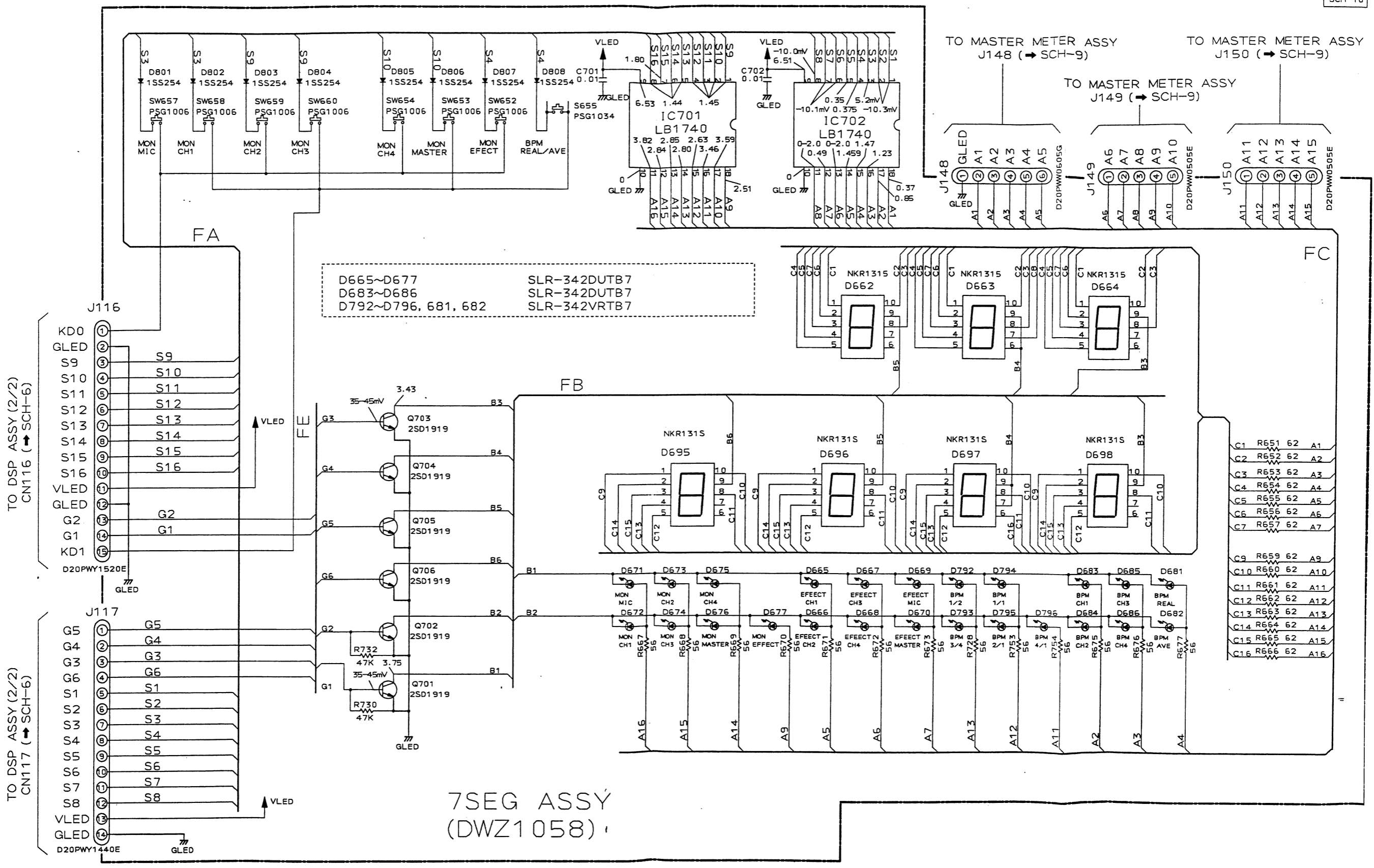

7SEG ASSY
(DWZ1058)

SCH-10

7SEG. ASSY

SCH-10

7SEG. ASSY

The parts mounted on this PCB include all necessary parts for several destinations.
For further information for respective destinations, be sure to check with the schematic diagram.

このPCB図にマウントしている部品は複数の仕向地を含んでいます。
各仕向地の情報は、回路図で確認するようにしてください。

This diagram is viewed from the mounted parts side.

この図は部品取付面側から見た図です。

PCB-6

CH1 METER ASSY

CH2 METER ASSY

CH3 METER ASSY

CH4 METER ASSY

MASTER METER ASSY

To DSP ASSY CN117

7SEG. ASSY

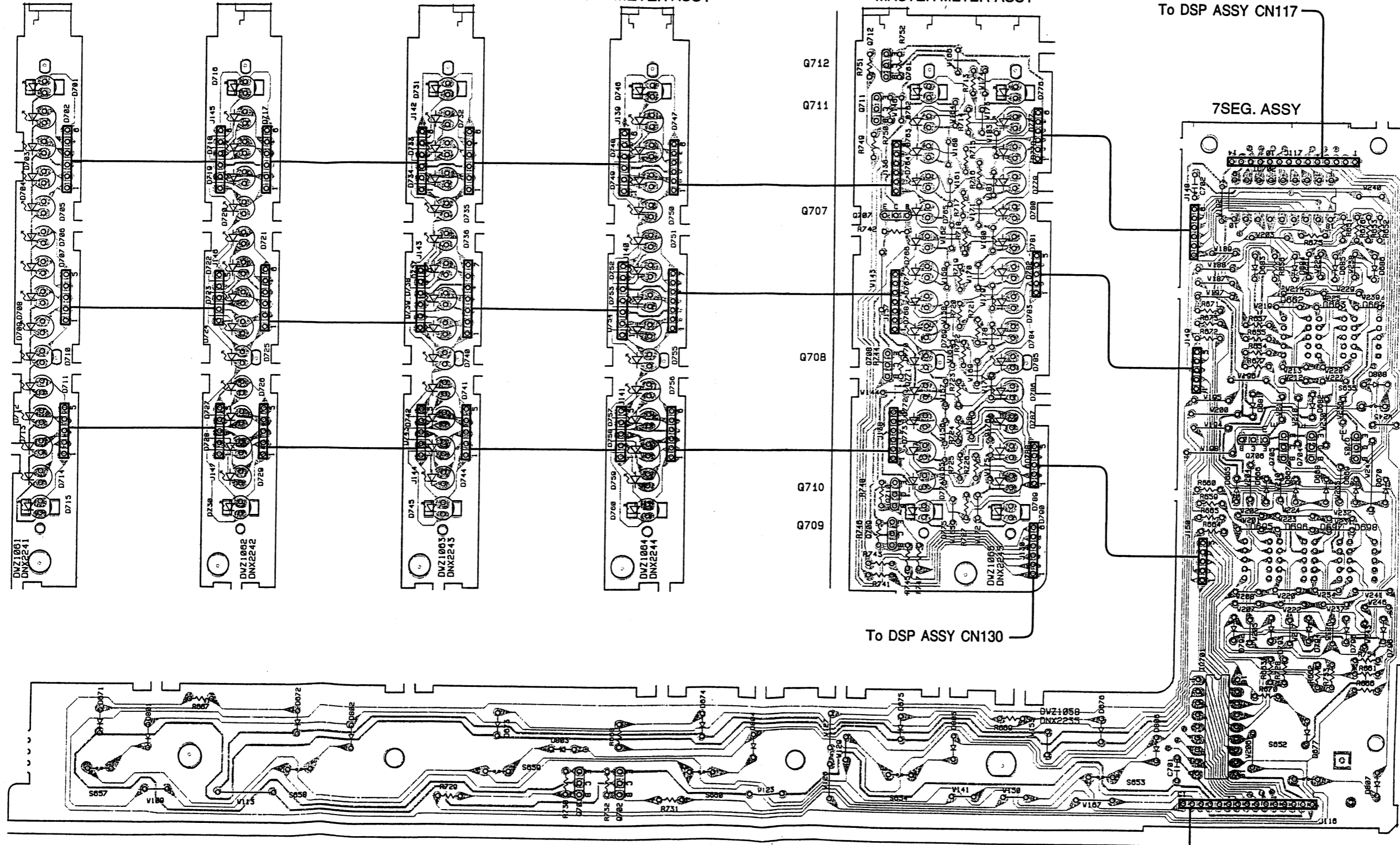

Q701 Q702

IC702 Q703-Q706
IC701

To DSP ASSY CN116

DJM-500

5. PCB PARTS LIST

NOTES:

- Parts marked by "NSP" are generally unavailable because they are not in our Master Spare Parts List.
- The Δ mark found on some component parts indicates the importance of the safety factor of the part. Therefore, when replacing, be sure to use parts of identical designation.
- Parts marked by "⊙" are not always kept in stock. Their delivery time may be longer than usual or they may be unavailable.
- When ordering resistors, first convert resistance values into code form as shown in the following examples.

Ex. 1 When there are 2 effective digits (any digit apart from 0), such as 560 ohm and 47k ohm (tolerance is shown by J = 5%, and K = 10%).

560 Ω \rightarrow $56 \times 10^1 = 561$ RD1/4PU 561J

47k Ω \rightarrow $47 \times 10^3 = 473$ RD1/4PU 473J

0.5 Ω \rightarrow 0R5 RN2H 0R5K

1 Ω \rightarrow 1R0 RS1P 1R0K

Ex. 2 When there are 3 effective digits (such as in high precision metal film resistors).

5.62k Ω \rightarrow $562 \times 10^1 = 5621$ RM1/4PC 5621F

Mark	No.	Description	Parts No.	Mark	No.	Description	Parts No.
LIST OF PCB ASSEMBLIES				FADER VR ASSY (MAIN)			
NSP		DSP ASSY	DWX1655			RESISTORS	
NSP		— EFFECT VR ASSY	DWG1472			VR135 (10k Ω -B)	DCV1004
NSP		— FADER VR ASSY (MAIN)	DWG1474			OTHERS	
NSP		— FADER VR ASSY (CH1)	DWG1475			CN135 6P JUMPER CONNECTOR	52151-0610
NSP		— FADER VR ASSY (CH2)	DWG1476			FADER VR ASSY (CH1)	
NSP		— FADER VR ASSY (CH3)	DWG1477			RESISTORS	
NSP		— FADER VR ASSY (CH4)	DWG1478			VR131 (10k Ω -B)	DCV1004
NSP		— DSP ASSY	DWZ1055			OTHERS	
NSP		— TERMINAL ASSY	DWZ1056			CN131 6P JUMPER CONNECTOR	52151-0610
NSP		VR ASSY	DWM1530			FADER VR ASSY (CH2)	
NSP		— VR ASSY	DWG1471			RESISTORS	
NSP		— PHONE JACK ASSY	DWZ1057			VR132 (10k Ω -B)	DCV1004
NSP		— MIC JACK ASSY	DWZ1066			OTHERS	
NSP		SUB ASSY	DWM1531			CN132 6P JUMPER CONNECTOR	52151-0610
NSP		— C.F ASSY	DWG1473			FADER VR ASSY (CH3)	
NSP		— VOLTAGE SELECT ASSY	DWR1241			RESISTORS	
NSP		— POWER SUP. ASSY	DWR1242			VR133 (10k Ω -B)	DCV1004
NSP		— POWER TRANS ASSY	DWR1243			OTHERS	
NSP		— INLET ASSY	DWR1244			CN133 6P JUMPER CONNECTOR	52151-0610
NSP		— POWER SW ASSY	DWR1245			FADER VR ASSY (CH4)	
NSP		— REG. ASSY	DWR1246			RESISTORS	
NSP		— TSEG. ASSY	DWZ1058			VR134 (10k Ω -B)	DCV1004
NSP		— BAL. OUT ASSY	DWZ1059			OTHERS	
NSP		— PHONE ASSY	DWZ1060			CN134 6P JUMPER CONNECTOR	52151-0610
NSP		— CH1 METER ASSY	DWZ1061			FADER VR ASSY (CH4)	
NSP		— CH2 METER ASSY	DWZ1062			RESISTORS	
NSP		— CH3 METER ASSY	DWZ1063			VR134 (10k Ω -B)	DCV1004
NSP		— CH4 METER ASSY	DWZ1064			OTHERS	
NSP		— MASTER METER ASSY	DWZ1065			CN134 6P JUMPER CONNECTOR	52151-0610
EFFECT VR ASSY				FADER VR ASSY (CH4)			
SEMICONDUCTORS				RESISTORS			
	Q173		2SC2458			VR134 (10k Ω -B)	DCV1004
	D171, D172		GL3HY43			OTHERS	
SWITCHES AND RELAYS						CN134 6P JUMPER CONNECTOR	52151-0610
	S174		DSG1052			FADER VR ASSY (CH4)	
	S171		DSG1053			RESISTORS	
	S173		DSG1056			VR134 (10k Ω -B)	DCV1004
RESISTORS						OTHERS	
	VR701 (10k Ω -B)		DCS1030			CN134 6P JUMPER CONNECTOR	52151-0610
	Other Resistors		RD1/6PM J				

6. IC INFORMATION

● The Information shown in the list is basic information and may not correspond exactly to that shown in the schematic diagram.

■ AK5345 (IC3: DSP ASSY)

● 16 bit 2ch A/D Converter

● Pin Assignment (Top view)

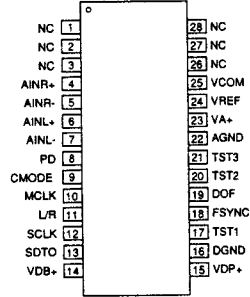

● Block Diagram

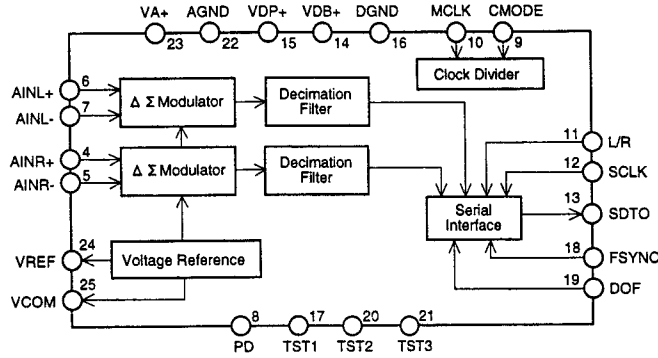

● Pin Function

NO.	Pin Name	I/O	Function
1	NC	—	Not used
2	NC	—	
3	NC	—	
4	AINR+	I	Rch analog positive input pin
5	AINR-	I	Rch analog negative input pin
6	AINL+	I	Lch analog positive input pin
7	AINL-	I	Lch analog negative input pin
8	PD	I	Power-down pin Power-down mode is reached at the time of "H". Offset calibration starts from "L". Calibration must be executed once at the time of power ON and when the clock frequency has been changed.
9	CMODE	I	Master clock selection pin "L": CLK = 256fs (12.288MHz @ fs = 48kHz) "H": CLK = 384fs (18.432MHz @ fs = 48kHz)
10	MCLK	I	Master clock input pin CMODE = "H": 384fs CMODE = "L": 256fs
11	L/R	I	Input channel selection pin fs clock is entered. At the time of DOF = "L", Lch is put out with "H" and Rch is put out with "L". At the time of DOF = "H", the polarity is reversed.
12	SCLK	I	Serial data clock pin 1 bit of the output data is put out with "↓" of this pin. A clock of 32fs to 64 fs is given as input.

NO.	Pin Name	I/O	Function
13	SDTO	O	Serial data output pin The data are put out as 2's complement, MSB first, 16 bit front justified data. "L" is put out after 16 bit output. "L" at the time of power-down (PD = "H").
14	VDB+	—	Digital part power supply pin, +5 V (silicon substrate potential)
15	VDP+	—	Digital part power supply pin, +5 V
16	DGND	—	Digital part ground pin
17	TST1	I	Test pin Set to open or "L".
18	FSYNC	I	Frame sync clock pin At the time of "H", SDATA is shifted according to SCLK.
19	DOF	I	Digital output format pin "L": Front justified "H": I ² S compatible format
20	TST2	O	Test pin Set to open for use.
21	TST3	O	
22	AGND	—	Analog ground pin
23	VA+	—	Analog power supply pin, +5 V
24	VREF	O	Reference voltage output pin, (VA+) -3.0 V Connect an electrolytic capacitor of 10 μF or less and a ceramic capacitor of 0.1 μF between VA+ and VREF.
25	VCOM	O	Common voltage output pin, (VA+) -2.5 V Connect a ceramic capacitor of 0.1 μF between VA+ and VCOM.
26	NC	—	Not used
27	NC	—	
28	NC	—	

■ NJM4556AL (IC232, IC233: PHONE ASSY)

● OP-AMP IC

● Pin Assignment

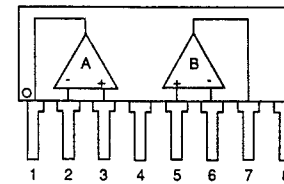

1. A OUTPUT
2. A -INPUT
3. A +INPUT
4. V-
5. B +INPUT
6. B -INPUT
7. B OUTPUT
8. V+

● Block Diagram

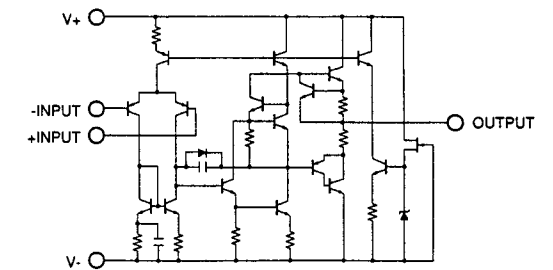

Mark No.	Description	Parts No.
R490-R498, R50, R53-R60 R99 R331, R332 R217 R203, R204, R212, R213		RD1/6PM223J RD1/6PM223J RD1/6PM272J RD1/6PM303J RD1/6PM332J
R309, R310, R360, R361 R77, R78 R417, R418, R439, R440 R461, R462, R483, R484 R223		RD1/6PM333J RD1/6PM333J RD1/6PM393J RD1/6PM393J RD1/6PM433J
R407, R408, R411, R412 R415, R416, R429, R430 R433, R434, R437, R438 R451, R452, R455, R456 R459, R460, R473, R474		RD1/6PM471J RD1/6PM471J RD1/6PM471J RD1/6PM471J RD1/6PM471J
R477, R478, R481, R482 R216, R219, R356, R357 R12, R3, R6, R9 R405, R406 R419, R420, R427, R428		RD1/6PM471J RD1/6PM472J RD1/6PM473J RD1/6PM562J RD1/6PM562J
R441, R442, R449, R450 R463, R464, R471, R472 R485, R486 R325, R326 R205, R206		RD1/6PM562J RD1/6PM562J RD1/6PM562J RD1/6PM563J RD1/6PM623J
R73, R74 R333, R334 Other Resistors		RD1/6PM752J RD1/6PM912J RS1/10S□□□J
OTHERS		
J110	CABLE HOLDER (7P) CABLE HOLDER (15P) CONNECTOR	51063-0705 51063-1505 PG06MR-E12
PHONE JACK ASSY		
OTHERS		
J109 JA301	3P JUMPER WIRE HEADPHONE JACK	D20PWW0315E VKN1149
MIC JACK ASSY		
OTHERS		
J120 CN201	3P JUMPER WIRE CONNECTOR	D20PWW0310E DKN1136
C.F ASSY		
RESISTORS		
VR1 (10kΩ-B)		DCV1003
OTHERS		
CN110	MT CONNECTOR (6P)	173979-6
VOLTAGE SELECT ASSY		
SWITCHES AND RELAYS		
△ S902		DSH1039
OTHERS		
△ J8	CONNECTOR ASSY	DKP3228

Mark No.	Description	Parts No.
POWER SUP. ASSY		
SEMICONDUCTORS		
	IC556, IC557	ICP-N15
	IC555	ICP-N25
	IC558	ICP-N50
△ IC554	PQ05RR12	
△ Q551	2SC2458	
△ Q550	2SD2395	
△ D562	1SS254	
△ D550	MTZJ7.5B	
△ D551, D552	SZVB20	
△ D559-D561	S5688G	
COILS AND FILTERS		
△ L901	VTL-004	
CAPACITORS		
△ C902, C903 (0.01 μ F/250V)	ACG7005	
C570	CEANP4R7M35	
C562	CEAS101M10	
C554, C555	CEAS101M16	
C567	CEAS221M16	
C561	CEAS330M16	
C556, C557	CEAS332M35	
C552, C553	CEAS470M16	
C571	CEAS4R7M50	
C550, C551, C558-C560, C563	CKCYF103Z50	
C565, C566, C568, C569	CKCYF103Z50	
C564 (10000 μ F/16V)	VCH1054	
RESISTORS		
All Resistors	RD1/6PM□□□J	
OTHERS		
CN119	MT CONNECTOR (11P)	1-173981-1
△ CN1	2P-VH CONNECTOR	B2P3-VH
△	HEAT SINK	DNG1066
△	HEAT SINK B	REF1003
H1-H4	FUSE HOLDER	RKR1003
POWER TRANS ASSY		
OTHERS		
CN8	3P-VH CONNECTOR	B3P5-VH
CN4	5P JUMPER CONNECTOR	KPC5
INLET ASSY		
INLET UNIT assy has no service part.		
POWER SW ASSY		
SWITCHES AND RELAYS		
△ S901	PSA-009	
CAPACITORS		
△ C901 (0.01 μ F/250V)	ACG7005	
REG. ASSY		
SEMICONDUCTORS		
△ IC550	NJM7815FA	
△ IC552	NJM78M06FA	
△ IC551	NJM7915FA	
△ IC553	NJM79M06FA	

Mark No.	Description	Parts No.
OTHERS		
J152	JUMPER WIRE (10P)	D20PWW1020E
△	HEAT SINK VR	VNH1049
7SEG. ASSY		
SEMICONDUCTORS		
	IC701, IC702	LB1740
	Q701-Q706	2SD1919
	D801-D808	1SS254
	D682-D664, D695-D698	NKR131S
	D665-D677, D683-D686	SLR-342DUTB7
	D681, D682, D792-D796	SLR-342VRTB7
SWITCHES AND RELAYS		
	S652-S654, S657-S660	PSG1006
	S655	RSG1034
CAPACITORS		
	C701, C702	CKPUYF103Z25
RESISTORS		
All Resistors		RD1/6PM□□□J
OTHERS		
	CUSHION (RUBBER)	REB1105
BAL. OUT ASSY		
CAPACITORS		
	C249-C252	CKCYF103Z50
OTHERS		
J108	JUMPER WIRE (6P)	D20PWW0610E
JA231, JA232	3P CANNON CONNECTOR	DRN1135
PHONE ASSY		
SEMICONDUCTORS		
	IC604	BU4066BC
	IC605	NJM2068D
	IC231	NJM4556AD
	IC232, IC233	NJM4556AL
	IC601-IC603	NJM4558DX
	IC17	NJM4580D
	Q604, Q605	2SC2458
	Q231-Q234	2SD2144S
	Q601	DTA124ES
	Q602, Q603	2SC2878
	D601-D608	1SS254
CAPACITORS		
	C602, C613, C614, C621, C622	CCCSL101J50
	C629, C630, C646-C652	CCCSL101J50
	C604	CCCSL220J50
	C640-C645	CCCSL270J50
	C603, C607-C609, C619, C620	CEAS100M16
	C625, C626, C631, C632	CEAS100M16
	C636, C637, C958	CEAS100M16
	C243-C246	CEAS101M25
	C231, C232, C241, C247, C601	CKCYF103Z50
	C605, C606, C610-C612	CKCYF103Z50
	C617, C618, C623, C624	CKCYF103Z50
	C627, C628, C633-C635	CKCYF103Z50
	C638, C639, C957	CKCYF103Z50
	C233-C240	CKPUYB15K50

Mark No.	Description	Parts No.
RESISTORS		
	R241-R248	RN1/6PQ1002F
	R233-R240	RN1/6PQ7500F
	Other Resistors	RD1/6PM□□□J
OTHERS		
	CN121	CABLE HOLDER (15P)
	JA601-JA607	5P JUMPER CONNECTOR
	KN601	MIC JACK
		EARTH METAL FITTING
		51063-1505
		52147-0510
		VKN1147
		VNF1084
CH1 METER ASSY		
SEMICONDUCTORS		
	D701-D706	SLB-25VRT52
	D707-D715	SLB-25MGT52
OTHERS		
	J146, J147	METER HOLDER
	J145	JUMPER WIRE
		JUMPER WIRE
		DNK3206
		DXYY0505E
		DXYY0605E
CH2 METER ASSY		
SEMICONDUCTORS		
	D716-D721	SLB-25VRT52
	D722-D730	SLB-25MGT52
OTHERS		
	J144	METER HOLDER
	J142, J143	JUMPER WIRE
		JUMPER WIRE
		DNK3206
		DXYY0505E
		DXYY0605E
CH3 METER ASSY		
SEMICONDUCTORS		
	D731-D736	SLB-25VRT52
	D737-D745	SLB-25MGT52
OTHERS		
	J141	METER HOLDER
	J139	JUMPER WIRE
	J140	JUMPER WIRE
		DNK3206
		DXYY0505E
		DXYY0605E
		DXYY0705E
CH4 METER ASSY		
SEMICONDUCTORS		
	D746-D751	SLB-25VRT52
	D752-D760	SLB-25MGT52
OTHERS		
	J136, J138	JUMPER WIRE (6P)
		METER HOLDER
		D20PWW0605G
		DNK3206
MASTER METER ASSY		
SEMICONDUCTORS		
	Q707-Q712	2SD1919
	D761-D766, D776-D781	SLB-25VRT52
	D767-D775, D782-D790	SLB-25MGT52
RESISTORS		
	All Resistors	RD1/6PM□□□J
OTHERS		
	J148	JUMPER WIRE (6P)
		METER HOLDER
		D20PWW0605G
		DNK3206

**TC9162AF (IC3, IC4, IC351, IC353: VR ASSY)
(IC165: DSP ASSY)**

● Analog Switch Array

● Pin Assignment (Top view)

● Block Diagram

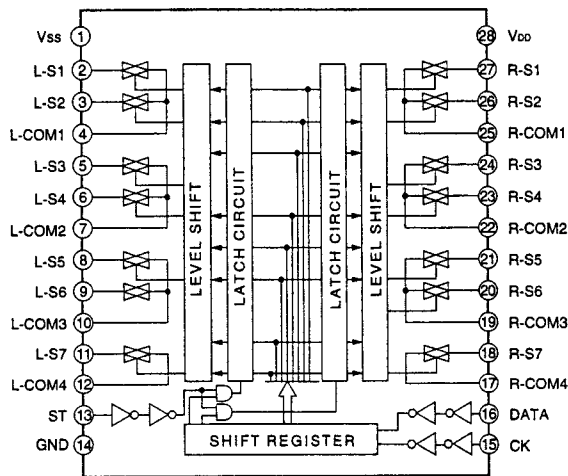
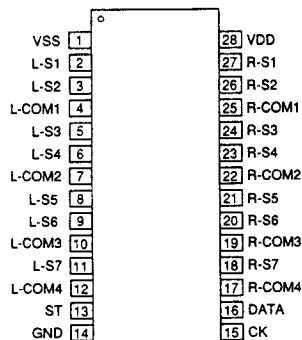

● Pin Function

NO.	Pin Name	Description
1	VSS	Power supply (-)
2, 27	S1	Switch input
3, 26	S2	
4, 25	COM1	Switch output
5, 24	S3	Switch input
6, 23	S4	
7, 22	COM2	Switch output
8, 21	S5	Switch input
9, 20	S6	

NO.	Pin Name	Description
10, 19	COM3	Switch output
11, 18	S7	Switch input
12, 17	COM4	Switch output
13	ST	Strobe input
14	GND	Ground
15	CK	Clock input
16	DATA	Data input
28	VDD	Power supply (+)

TC9163AF (IC167: DSP ASSY)

● Analog Switch Array

● Pin Assignment (Top view)

● Block Diagram

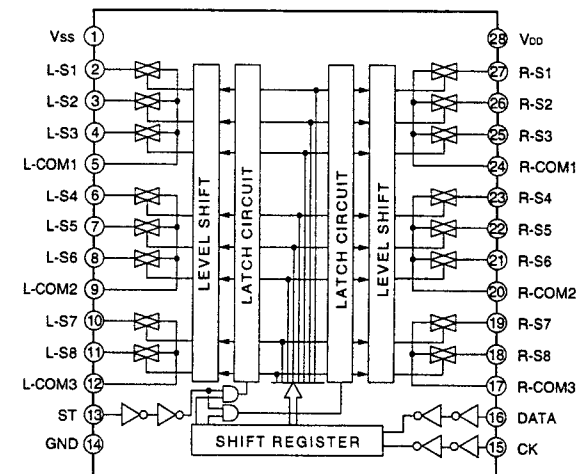
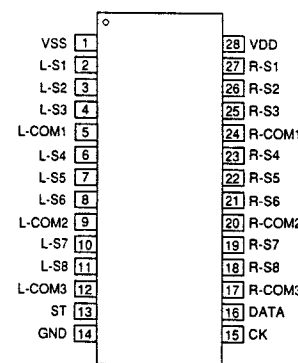

● Pin Function

NO.	Pin Name	Description
1	VSS	Power supply (-)
2, 27	S1	Switch input
3, 26	S2	
4, 25	S3	Switch input
5, 24	COM1	
6, 23	S4	Switch input
7, 22	S5	
8, 21	S6	Switch input
9, 20	COM2	

NO.	Pin Name	Description
10, 19	S7	Switch input
11, 18	S8	
12, 17	COM3	Switch output
13	ST	Strobe input
14	GND	Ground
15	CK	Clock input
16	DATA	Data input
28	VDD	Power supply (+)

■ PD4669A (IC14: DSP ASSY)

● System Control Micro-computer

● Pin Function

No.	PORT	Pin Name	I/O	Function
1	P94/FIP6	GRID	O	7 Segment display output
5	P90/FIP2			
6	P81/FIP1			
7	P82/FIP0			
8	VDD	—	—	Power supply
9	P27/SCK0	XSCK	O	DSP serial communication clock output
10	P26/SO0/SB1	SI	O	DSP serial data output
11	P25/SI0/SB0	XSTART	I	Effect ON/OFF ON: L, OFF: H
12	P24/BUSY	STB1	O	Analog switch IC selection signal 1
13	P23/STB	ADSW	O	Switching analog switch
14	P22/SCK1	ICCLK	O	Analog switch IC serial communication clock output
15	P21/SO1	ICDATA	O	Analog switch IC serial data output
16	P20/SI1	STB2	O	Analog switch IC selection signal 2
17	XRESET	XRST	I	Micro-computer reset H: Reset
18	P74	FSC2	I	CH2 Fader control ON/OFF ON: L
19	P73	FSC1	I	CH1 Fader control ON/OFF ON: L
20	AVSS	GRF	—	GND for A/D converter
21	P17/ANI7	EFVR	I	EFFECT VR
22	P16/ANI6	A/D1	I	EFS: H / ECHS: L
23	P15/ANI5	A/D3	I	MASL: H / MASR: L
24	P14/ANI4	A/D4	I	MCH3: H / MCH4: L
25	P13/ANI3	A/D5	I	MCH1: H / MCH2: L
26	P12/ANI2	A/D6	I	CH1
27	P11/ANI1	A/D7	I	Assign B: H / CH2: L
28	P10/ANI0	A/D8	I	CFAS: H / Assign A: L
29	AVDD	—	—	Power supply for A/D converter
30	AVREF	—	—	A/D converter reference voltage input
31	P04/XT1	RDY1	I	DSP serial communication RDY signal
32	XT2	—	—	Connected to crystal for sub system clock oscillation
33	VSS	—	—	GND
34	X1	—	—	Connected to crystal for main system clock oscillation
35	X2			
36	P37	PD	O	A/D converter (DSP) PD
37	P36/BUZ	XRT2	O	XRST2 (DSP)
38	P35/PCL	XC/D	O	XC/D (DSP)

No.	PORT	Pin Name	I/O	Function	
39	P34/TI2	CS1	O	CS1 (DSP)	
40	P33/TI1	STB4	O	Analog switch IC selection signal 4	
41	P32/TO2	GF3	I	BPM monitor channel selection	"H" level signal
42	P31/TO1	GF2	I		"M" level signal
43	P30/TO0	GF1	I		"L" level signal
44	P03/INTP3/CI0	GFB3	I	BPM effect channel selection	"H" level signal
45	P02/INTP2	GFB2	I		"M" level signal
46	P01/INTP1	STB3	O	Analog switch IC selection signal 3	
47	P00/INTP0/TI0	GFB1	I	BPM effect channel selection	"L" level signal
48	IC (VPP)	—	—	Internal connection	
49	P72	KD1	I	Key read	
50	P71	KD0	I		
51	P70	MCFSW	I	Switching fader	Cross: L CH:H
52	—	VDD	—	Power supply +5V	
53	P127/FIP33	BPM/EFEC	O	BPM mode: H Effect mode: L	
54	P126/FIP32	MUTE	O	Mute control	Mute: L
55	P125/FIP31	CH2CT2	O	Player control signal	CH2 STOP:H
56	P124/FIP30	CH2CT1	O		CH2 START:H
57	P123/FIP29	CH1CT2	O		CH1 STOP:H
58	P122/FIP28	CH1CT1	O		CH1 START:H
59	P121/FIP27	SEG	—	7 Segment display output	
60	P120/FIP26				
61	P117/FIP25				
62	P116/FIP23				
68	P110/FIP17				
69	P107/FIP17				
70	P106/FIP16				
71	VLOAD	—	—	Connected to FIP driver pull-down resistor.	
72	P105/FIP15	SEG	—	7 Segment display output	
75	P102/FIP12				
76	P101/FIP11	GRID	—	7 Segment display output	
77	P100/FIP10				
78	P97/FIP9				
80	P95/FIP7				

■ AUTO BMP COUNTER SELECTOR SECTION

● Removal of the Fader VR Assy (Fig. 5)

1. Remove the control panel. (Refer to the preceding item.)
2. Remove the two screws ① fixing the Fader VR assy.
3. Slide the Fader VR assy to the side and then raise it.
4. Proceed in the same way for CH2 to CH4.

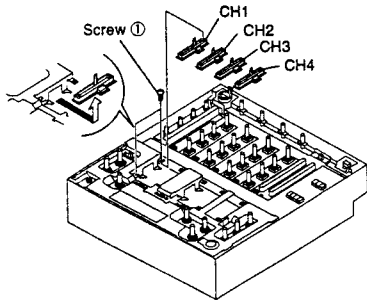

■ EFFECT SELECTOR SECTION

● Removal of the Effect VR Assy (Fig. 6, 7)

1. Remove the control panel. (Refer to the preceding item.)
2. Remove the nut and washer ①.
3. Place the panel assy as shown in the figure.
4. Remove the two screws ② fixing the cable cover and the PC support.
5. Remove the two screws ③ fixing the Effect VR assy.

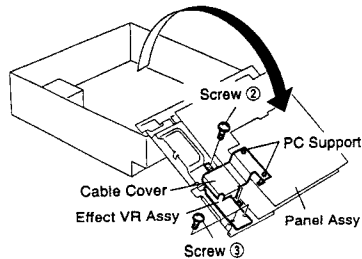
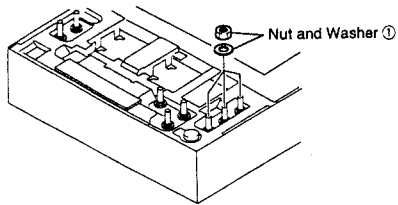

■ REMOVAL OF THE TERMINAL ASSY

1. Remove the control panel. (Refer to the preceding item.) (The knobs don't have to be removed.)
2. Remove the five screws 1 fixing the Terminal assy (at the rear panel).
3. Place the panel assy as shown in the figure.

Note: Place a cloth etc. between the panel and the chassis to prevent damaging the panel surface.

4. Remove the screw ② (PCB) and the hook of the PCB spacer.

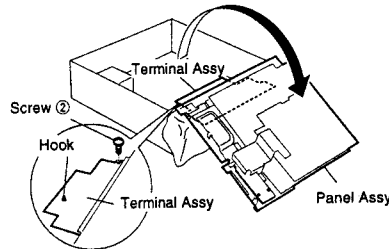
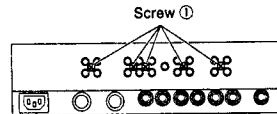

■ REMOVAL OF THE PHONE ASSY

1. Remove the control panel. (Refer to the preceding item.) (The knobs don't have to be removed.)
2. Remove the seven nuts and washers ① fixing the Phone assy (at the rear panel).
3. Remove the Terminal assy. (Refer to the preceding item.)
4. Remove the screw ② (PCB) and the two PC support hooks.

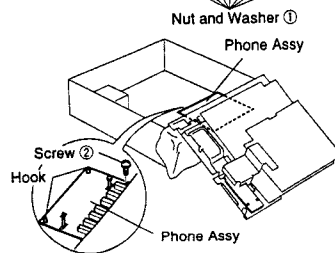
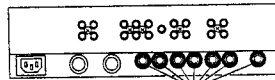

8. PANEL FACILITIES

Rear section

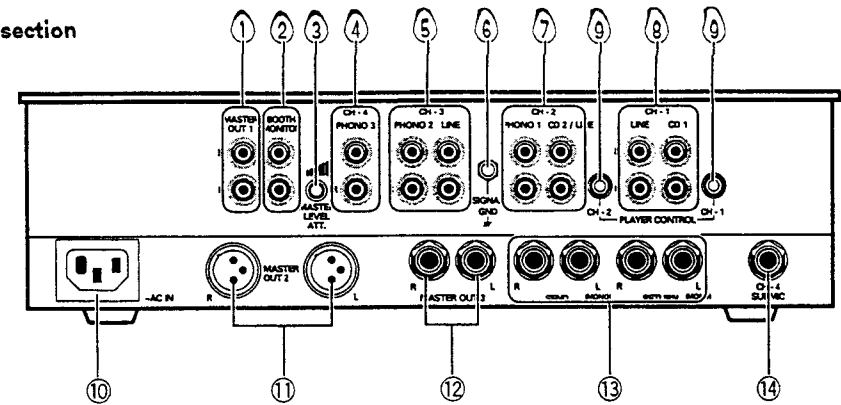

- ① Master Output 1 Terminal (MASTER OUT 1)
Connects the power amplifier using a cord with RCA plug.

- ② Booth Monitor Output Terminal (BOOTH MONITOR)
Connects the power amplifier which connects the speaker for monitoring audio.

- ③ Master Output Level Adjustment Knob (MASTER LEVEL ATT.)

- ④ CH-4 Phono Input Terminal (PHONO 3)
PHONO 3 : Connects the analog player. (for MM only)

- ⑤ CH-3 Input Terminal
PHONO 2 : Connects the analog player. (for MM only)
LINE : Connects audio equipment such as DAT.

- ⑥ Ground Terminal (SIGNAL GND)
Connects to the GND cord of the analog player.

This terminal is for only an analog player, not for a safety ground.

- ⑦ CH-2 Input Terminal
PHONO 1 : Connects to the analog player. (for MM only)
CD/LINE : Connects optional CD players such as CDJ-500II

- ⑧ CH-1 Input Terminal
LINE : Connects audio equipment such as a cassette deck, etc.
CD : Connects optional CD players such as the CDJ-500II

- ⑨ CH-1, 2 Player Control Terminal
When connecting the optional CDJ-500II or CDJ-500G to the CD terminals of CH-1 or CH-2, the fader start function can be used by connecting this terminal to the control terminal of the player.

- ⑩ Power Cord Connection Terminal
Connects the power cord provided.

- ⑪ Master Output 2 Terminal (MASTER OUT 2)
Connects the XLR input supporting power amplifier.

- ⑫ Master Output 3 Terminal (MASTER OUT 3)
Connects the PHONE input supporting power amplifier.

- ⑬ External Effector Connecting Terminal (SEND, RETURN)
Used to connect other equipment for adjusting sound.
SEND (Output) : Connects the input terminal of the external effector.
Uses L channel output for using the effector of monaural input.
The sound that L and R are mixed will be sent to the effector.
RETURN (Input) : Connects the output terminal of the external effector.
Uses L channel input for using the effector of monaural input. It will be input to both channels L and R.

- ⑭ CH-4 Sub Microphone Input Terminal (SUB MIC)

■ TC9164AF (IC1: VR ASSY)

● Analog Switch Array

● Pin Assignment (Top view)

● Block Diagram

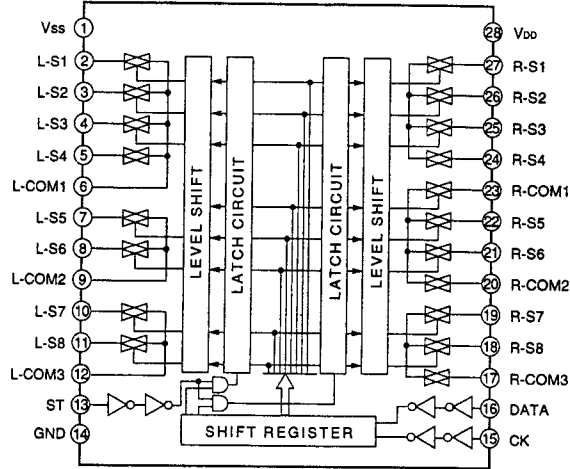
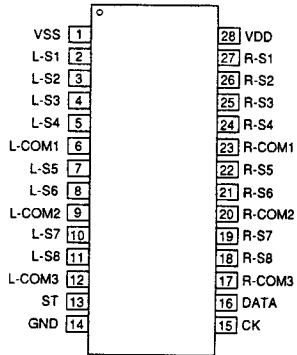

● Pin Function

NO.	Pin Name	Description
1	VSS	Power supply (-)
2, 27	S1	Switch input
3, 26	S2	
4, 25	S3	
5, 24	S4	
6, 23	COM1	Switch output
7, 22	S5	Switch input
8, 21	S6	
9, 20	COM2	

NO.	Pin Name	Description
10, 19	S7	Switch input
11, 18	S8	
12, 17	COM3	Switch output
13	ST	Strobe input
14	GND	Ground
15	CK	Clock input
16	DATA	Data input
28	VDD	Power supply (+)

7. DISASSEMBLY

■ CROSS-FADER SECTION (Fig. 1)

1. Remove the fader knob.
2. Remove the two screws ① fixing the slider panel.
3. Raise the C.F. assy at the front and then raise the entire unit.

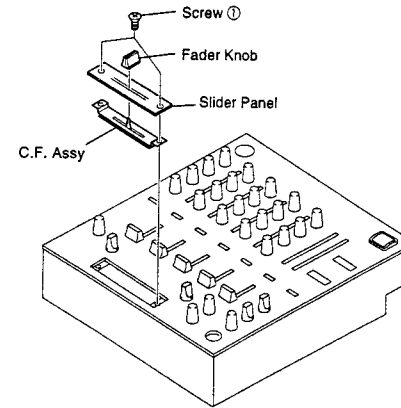

■ CONTROL PANEL SECTION (Fig. 2)

1. Remove all knobs from the control panel surface.
2. Remove the six screws ①.
3. Remove the two screws ② fixing the microphone jack.

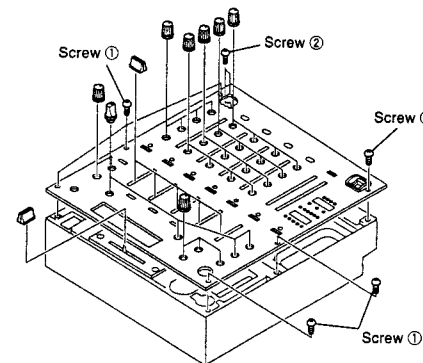

■ EQUALIZER SECTION

● Removal of the CH1 to CH4 Meter Unit (Fig. 3)

1. Remove the control panel. (Refer to the preceding item.)
2. Remove the four screws ① fixing each meter assy.
3. Slide the meter assy to the front and raise it.
4. Proceed in the same way for CH2 to CH4.

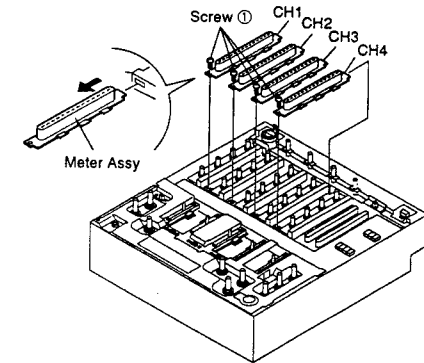

● Removal of Shield Plate (Fig. 4)

1. Remove the control panel. (Refer to the preceding item.)
2. Remove the meter assy. (Refer to the preceding item.)
3. Remove the two screws ① fixing the shield plate.
4. Remove the nut and washer ② fixing the VR, and then remove the shield plate.
5. Proceed in the same way for CH2 to CH4.

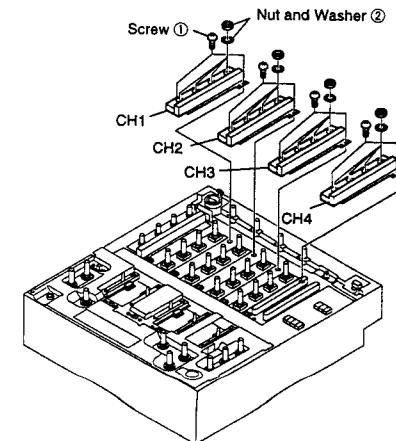

- ⑨ **Monitor Monaural/Stereo Selector Switch (MONO/STEREO)**
Used to obtain the beat easily with the headphone monitor sound.
Increases/decreases low tone.
Flat at center click.
Increases when rotated to the right. (To +12 dB at 100 Hz)
Decreases when rotated to the left. (To -12 dB at 100 Hz)
- ⑩ **Monitor Equalizer Knob (MONITOR EQ)**
Increases/decreases low tone.
Flat at center click.
Increases when rotated to the right. (To +12 dB at 100 Hz)
Decreases when rotated to the left. (To -12 dB at 100 Hz)
- ⑪ **Monitor Level Knob (MONITOR LEVEL)**
Used for adjusting the headphone monitor volume.
Not affected by the master volume and master balance.
- ⑫ **Headphone Terminal (PHONES)**
- ⑬ **Channel Fader Volume**
Used for adjusting the volume of CH1 to CH4.
- ⑭ **Assign Switch (ASSIGN A, B)**
When performing cross fader using two sources (A, B), select the channels (CH1 to CH4) to be assigned to A and B.
Effective when the cross fader switch (⑩) is on (cross fader mix).
- ⑮ **Fader Start Switch (FADER START) (Refer to Page 17.)**
When the optional CD player (CDJ-500G or CDJ-500II) is connected to the unit using the control cord, this ON/OFF switch is used to start automatic playing of the CD player using the channel fader or cross fader.
- ⑯ **Cross Fader Volume (CROSS FADER)**
Adjusts the mix volume of the sources set to A and B using the assign switch (⑭).
- ⑰ **Cross Fader Switch (CROSS FADER ON/OFF)**
OFF:
Select when mixing sounds using the channel fader volume. (Direct mix.)
ON:
Select when mixing sounds using the cross fader. (Cross fader mix.)
- ⑱ **Master Volume Level Adjustment**
Used to adjust the level of the master output volume.
When the cross fader is ON, the sounds of assigns A, B and main microphone will be output.
When the cross fader is OFF, the sounds of each channel and main microphone will be output.

- ⑲ **Master Balance Knob (MASTER BALANCE)**
Used to adjust the left and right balance of the master output.
- ⑳ **Booth Monitor Level Knob (BOOTH MONITOR LEVEL)**
Used to adjust the output level of the BOOTH MONITOR terminal.
Not affected by the master volume and master balance.
- ㉑ **Effect Selector Switch (EFFECT SELECTOR)**
AUTO BPM (Beat/minute):
Select when performing BPM detection.
DELAY:
Delays the time and repeats once.
ECHO:
Delays the time and repeats several times to produce the echo effects.
AUTO PAN:
Shifts the left and right channels periodically.
FLANGER:
Produces periodic sound change effects by mixing the short delay sound and original sound.
REVERB:
Produces the reverb effects.
PITCH SHIFTER:
Changes the pitch of the song.
SEND/RETURN:
Select when connecting and using the external effector.
- ㉒ **Effect Channel Selector (CH. SELECTOR)**
Use to select the source to be effected.
- ㉓ **Parameter Knob (PARAMETER)**
Used to adjust the parameter of the effector selected with the effect selector switch.
DELAY:
0 to 680 mSec (2 mSec step to 100, 5 mSec step from 100 to 680)
ECHO:
0 to 680 mSec (2 mSec step to 100, 5 mSec step from 100 to 680)
AUTO PAN:
0 to 3500 mSec (5 mSec to 100, 10 mSec from 100 to 900, 20 mSec step from 900 to 3500)
FLANGER:
100 to 9000 mSec (10 mSec to 900, 50 mSec from 900 to 9000)
REVERB:
0 to 100% (1% step)
PITCH SHIFTER:
0 to ±100% (1% from 0 to 10, 2% step from 10 to 100)
- ㉔ **Effect Switch (EFFECT ON/OFF)**
Use to switch the effect on/off.
When turned on according to the beat, the effects will also correspond to the beat.
When the effect is on, it goes on and off.

9. SPECIFICATIONS (for KUC type)

Audio Section

Input terminal (Input level/impedance)	
CD/LINE	-14 dBV (200 mV) / 22 kΩ
PHONO	-54 dBV (2 mV) / 47 kΩ
MAIN MIC	-54 dBV (2 mV) / 3 kΩ
SUB MIC	-60 dBV (1 mV) / 3 kΩ
RETURN	-14 dBV (200 mV) / 22 kΩ

Output terminal (Output level/impedance)	
MASTER OUT 1 (RCA)	0 dBV (1 V) / 1 kΩ
MASTER OUT 2 (XLR)	4 dBm (1.23 V) / 600 Ω
MASTER OUT 3 (1/4"PHONE)	0 dBV (1 V) / 1 kΩ
BOOTH MONITOR	0 dBV (1 V) / 1 kΩ
SEND	0 dBV (1 V) / 1 kΩ
PHONES	-4 dBV (0.63 V) / 22 Ω

Frequency characteristics	
CD/LINE	20 Hz to 20 kHz (±0.5 dB)
PHONO	20 Hz to 20 kHz (±1.5 dB/RIAA)
MIC	20 Hz to 20 kHz (±2 dB)

SN ratio	
CD/LINE	85 dB
PHONO	77 dB
MIC	69 dB

Total harmonic distortion rate	
CD/LINE ,PHONO ,MIC	Below 0.02 %

Cross talk	70 dB
------------------	-------

Channel equalizer	
LOW	+12 dB, -20 dB (100 Hz)
MID	+12 dB, -20 dB (1 kHz)
HI	+12 dB, -20 dB (10 kHz)

Microphone equalizer	
LOW	±12 dB (100 Hz)
MID	±12 dB (1 kHz)
HI	±12 dB (10 kHz)

Monitor equalizer	±12 dB (100 Hz)
-------------------------	-----------------

Effector	
Delay, echo	0 to 680 mSec
Auto pan	0 to 3500 mSec
Flanger	100 to 9000 mSec
Reverb	0 to 100 %
Pitch shifter	0 to ±100 %

Electrical Section, Others

Power supply voltage	AC 100 V ±5 %
Power consumption	41 W
Operating temperature	+5 °C to +35 °C
Operating humidity	5 % to 85 %
External dimensions	320 (W) × 357.4 (D) × 107 (H) mm
Weight	12-5/8 (W) × 14-1/16 (D) × 4-3/16 (H) in
	5.9 kg (13 lb)

Accessories

- Power cord
- Operating instructions

NOTE:
Specifications and the design are subject to possible modifications without notice, due to improvements.

Front section

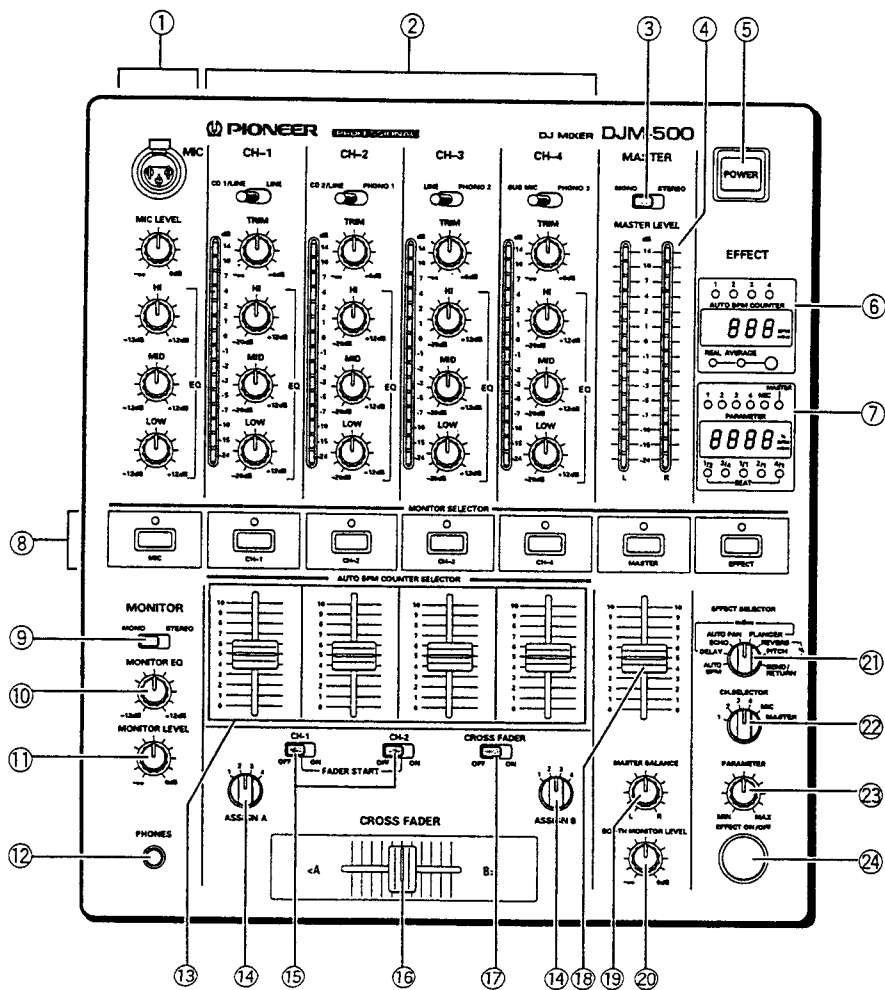

① Main Microphone Terminal and Microphone Control Knob

MIC Level:
Used for adjusting the volume of the main microphone.
(Attenuated level → to 0 dB)

HI:
Used for adjusting the high tone of the microphone sound.
Flat at center click.

Increases when rotated to the right. (To +12 dB at 10 kHz)
Decreases when rotated to the left. (To -12 dB at 10 kHz)

MID:
Used for adjusting the middle tone of the microphone sound.
Flat at center click.

Increases when rotated to the right. (To +12 dB at 1 kHz)
Decreases when rotated to the left. (To -12 dB at 1 kHz)

LOW:
Used for adjusting the low tone of the microphone sound.
Flat at center click.

Increases when rotated to the right. (To +12 dB at 100 Hz)
Decreases when rotated to the left. (To -12 dB at 100 Hz)

② CH1 to CH4 Input Selection Switch and Control Knob/Peak level meter

Input selection switch:
Selects which sound of the two units connected to each CH to use.

- CH1 : Switches between CD1/LINE and LINE
- CH2 : Switches between CD2/LINE and PHONO 1
- CH3 : Switches between LINE and PHONO 2
- CH4 : Switches between SUB MIC and PHONO 3

TRIM:
Used for adjusting the level of the input signal.
The level increases when rotated to the right. (To +6 dB)
The level decreases when rotated to the left. (To →)

HI:
Used for adjusting the high tone.
Flat at center click.

Increases when rotated to the right. (To +12 dB at 10 kHz)
Decreases when rotated to the left. (To -20 dB at 10 kHz)

MID:
Used for adjusting the middle tone.
Flat at center click.

Increases when rotated to the right. (To +12 dB at 1 kHz)
Decreases when rotated to the left. (To -20 dB at 1 kHz)

LOW:
Used for adjusting the low tone.
Flat at center click.

Increases when rotated to the right. (To +12 dB at 100 Hz)
Decreases when rotated to the left. (To -20 dB at 100 Hz)

Peak level meter:
Displays the peak level holding it for two seconds.
Displays the level before channel fader.

The display range is -24 dB to +14 dB.
When BPM is selected using the effect selector and the effect switch is turned on, the beat monitor function will be turned on.

③ Master Output Monaural/Stereo Selection Switch (MONO/STEREO)

④ Master level meter (MASTER LEVEL)
Displays the output level after master volume adjustment while holding it for 2 seconds.
The display range is -24 dB to +14 dB.

⑤ Power Supply Switch (POWER)

⑥ BPM Display
• When BPM is selected using the effect selector, the BPM of the source selected with the monitor selector (CH1 to CH4) will be displayed.

1 to 4:
Displays the channel measuring the BPM.

Counter:
Displays the BPM value.

Real-time/average selection button and indicator:
(When REAL is selected.)
The counter displays the measured BPM value.

It will be displayed blinking. If it could not be measured for more than 5 seconds, "—" is displayed.
(When AVERAGE is selected.)
The display changes when it could be measured.

While measuring, the previous value will remain displayed.

• When other than BPM is selected using the effect selector (DELAY, ECHO, AUTO PAN, FLANGER), the source BPM selected using the effect channel selector (2) is converted to hours and displayed on the counter.

⑦ Effector Parameter/BPM Display

1 to 4 MIC MASTER:
Displays the effect source.

Counter:
Displays the effect source BPM and effect parameter, etc. (Refer to 3 for details of the parameter.)
BPM...375 to 857 mSec (1 mSec step)
70.0 to 160.0 BPM (0.1 BPM step)

BEAT:
When the effect is set to delay, echo, auto pan, or flanger, displays to which beat the parameter is set. (1/2 to 4 beats)

⑧ Monitor Selector/Auto BPM Counter Selector button (MONITOR SELECTOR/AUTO BPM COUNTER SELECTOR)

• Selects the source which is monitored using the headphone (CH1 to 4, MIC, MASTER, EFFECT).
When several buttons are pressed, sounds can be mixed. When the button is pressed another time, the selection is canceled.

• When BPM is selected using the effect selector, the channel displaying the BPM (CH1 to CH4) is selected. When more than two are selected together, BPM will not be displayed properly.