

Highes & Kettner TECHNOLOGY OF TONE		Drawn By: M. Bohlender
Title: ZenAmp		Date: 04-Dec-2001
POWERAMP, POWER SUPPLY, INPUT SECTOR		Drawing-Nr.: HU0100-SP-R01-1C
Filename: HU0100-SP-R01-1C-041201.big	Checked by: Michael Bohlender 04-Dec-2001	Page: 1/3

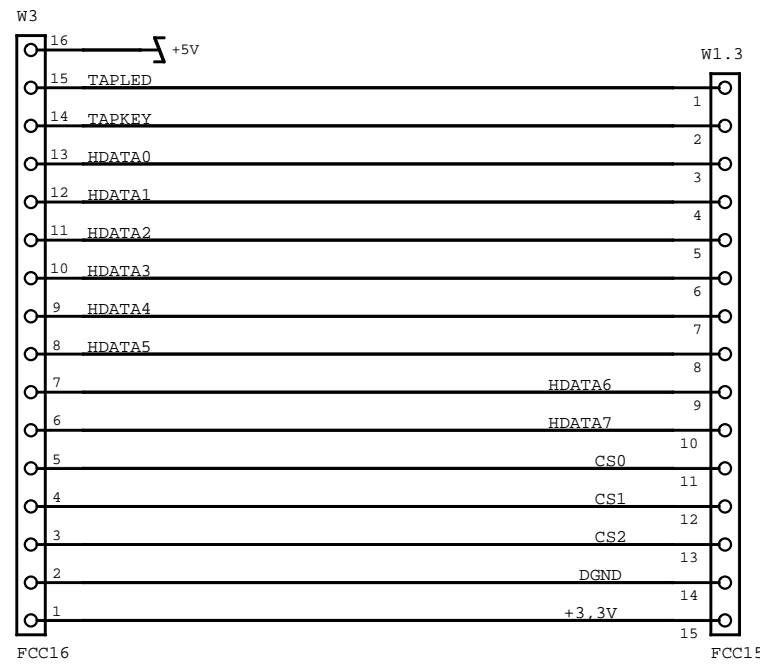

to DSP-Module

		Drawn By: M. Bohlender
		Date: 04-Dec-2001
Title: ZenAmp POWERAMP, POWER SUPPLY, INPUT SECTOR		Drawing-Nr.: HU0100-SP-R01-1C
Filename: HU0100-SP-R01-1C-041201.big	Checked by: Michael Bohlender 04-Dec-2001	Page: 2 / 3

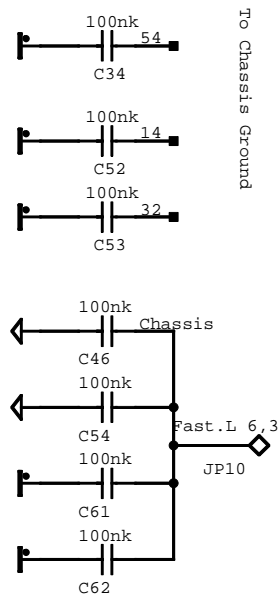
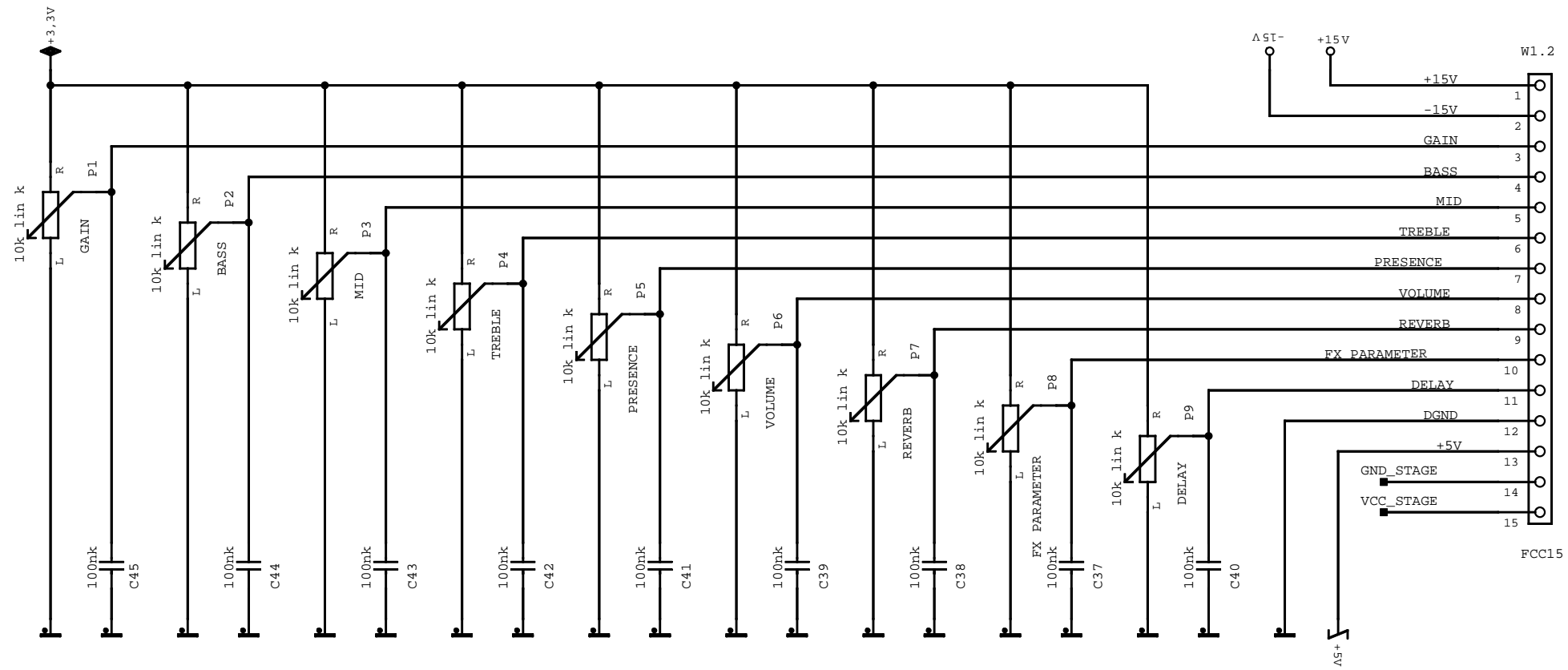
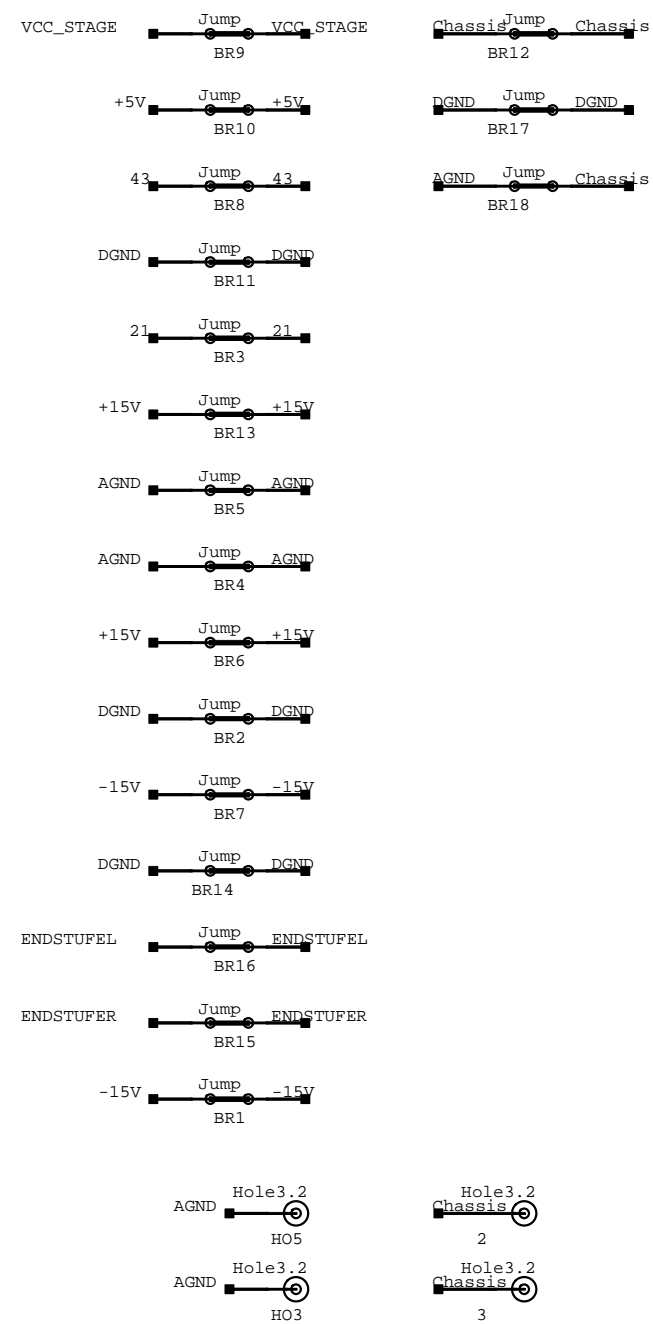

		Drawn by: M. Bohlender
		Date: 04-Dec-2001
Title: ZenAmp POWERAMP, POWER SUPPLY, INPUT SECTOR		Drawing-Nr.: HU0100-SP-R01-1C
Filename: HU0100-SP-R01-1C-041201.big	Checked by: Michael Bohlender 04-Dec-2001	Page: 3 / 3

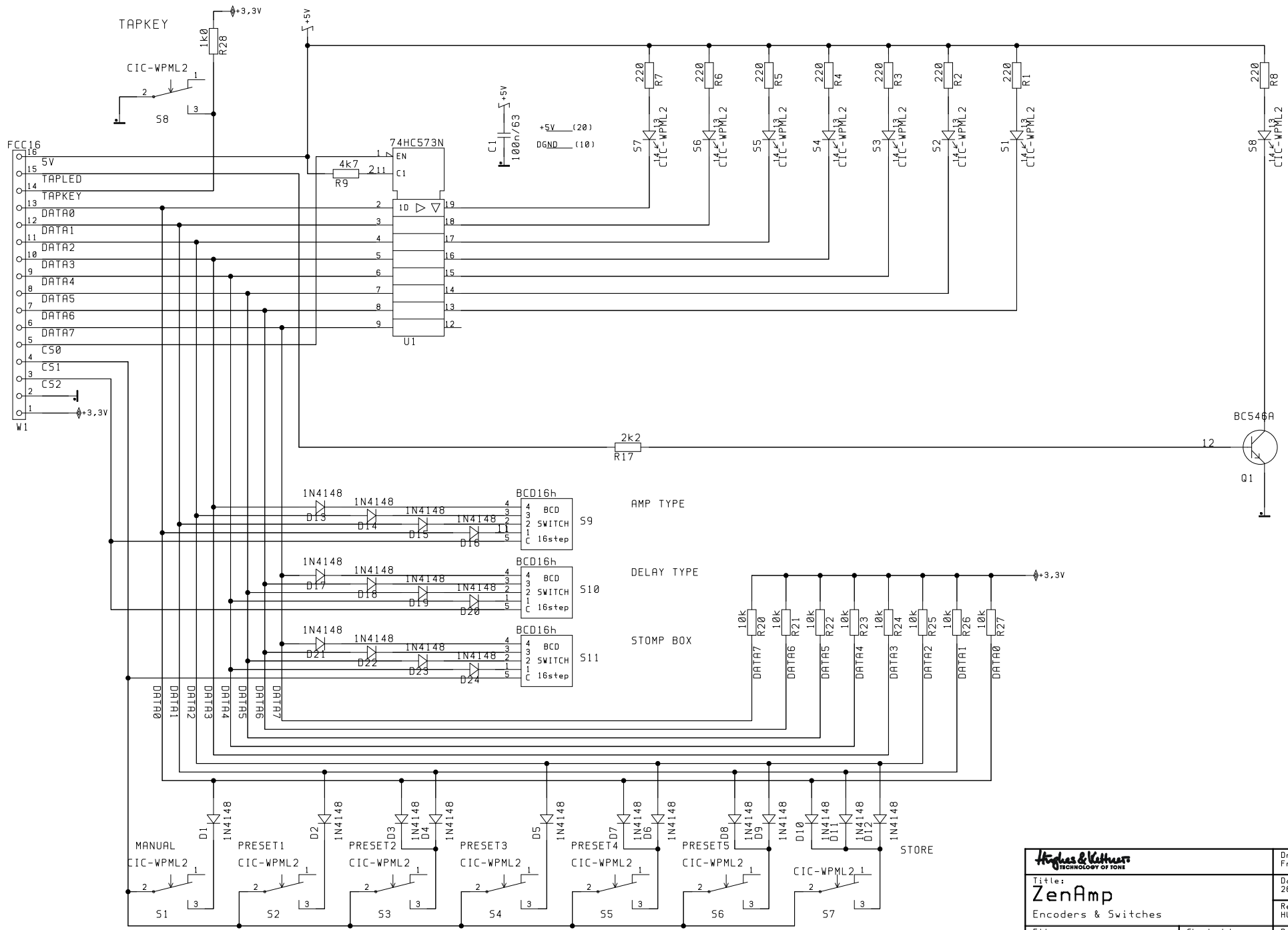

Highes & Kalthers TECHNOLOGY OF TONE		Drawn by: Frank Sitter
ZenAmp Encoders & Switches		Date: 26-Feb-01
		Ref.-Nr.: HU0100-5P-R02-1A
Filename: HU0100-5P-R02-1A-030901.big	Checked by: Alexander Peter 03-Sep-2001	Page: 1 / 2

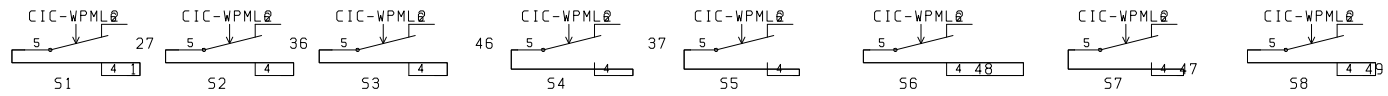
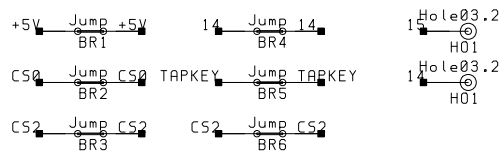

Hughes & Kottner <small>TECHNOLOGY OF TONE</small>		Drawn by: Frank Sitter
Title: ZenAmp Encoders & Switches		Date: 26-Feb-01
Filename: HU0100-SP-R02-1A-030901.big		Ref.-Nr.: HU0100-SP-R02-1A
Checked by: Alexander Peter 03-Sep-2001		Page: 2 / 2

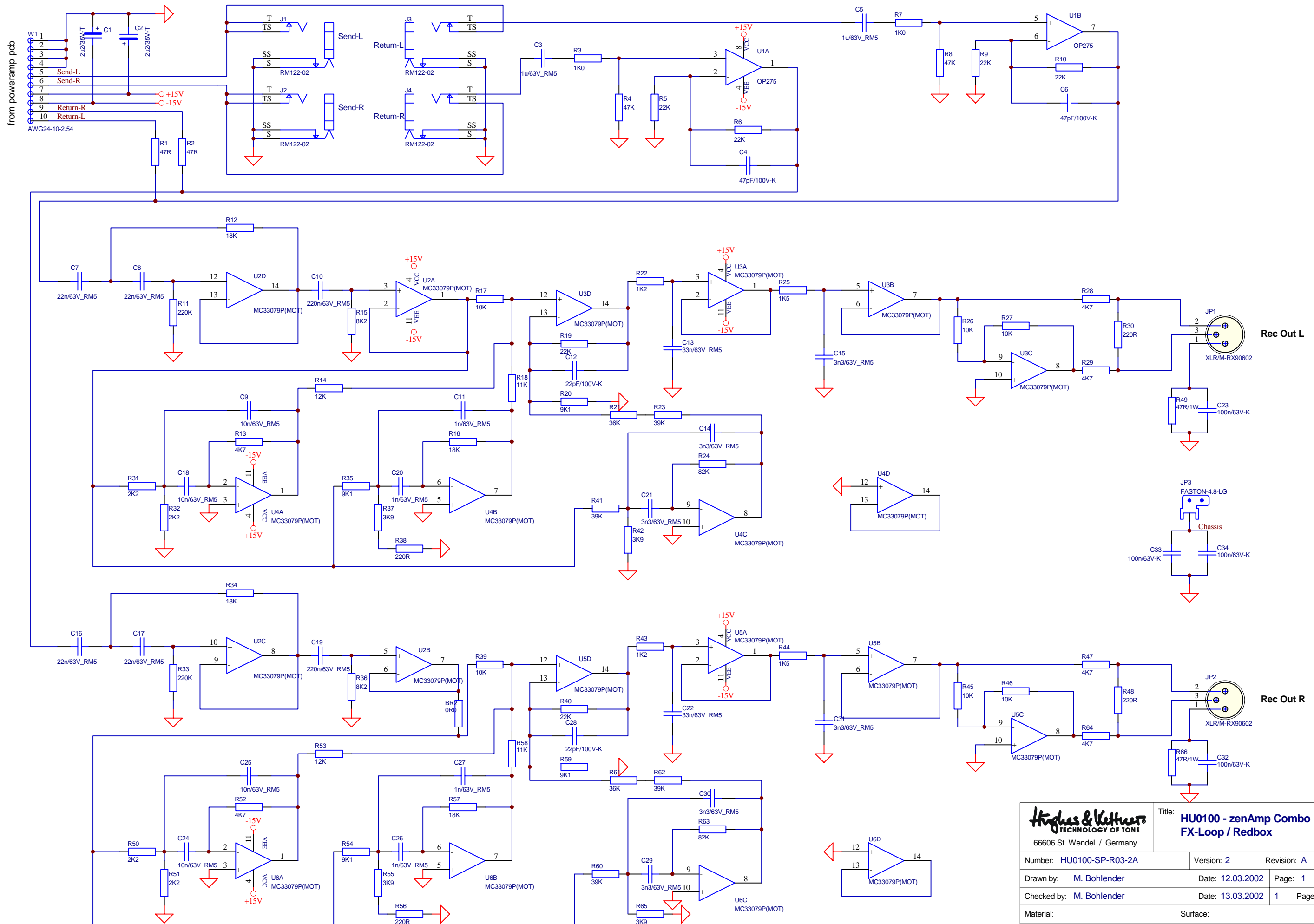

All rights reserved. No part of this schematic may be reproduced, stored in a retrieval system, transmitted in any form or by any means, electronic, mechanical, photocopying, recording or otherwise, without the prior permission of the author.

		Title: HU0100 - zenAmp Combo FX-Loop / Redbox	
		66606 St. Wendel / Germany	
Number: HU0100-SP-R03-2A	Version: 2	Revision: A	
Drawn by: M. Bohlender	Date: 12.03.2002	Page: 1	
Checked by: M. Bohlender	Date: 13.03.2002	1 Pages	
Material:	Surface:		
Filename: HU0100-SP-R03-2A.sch			

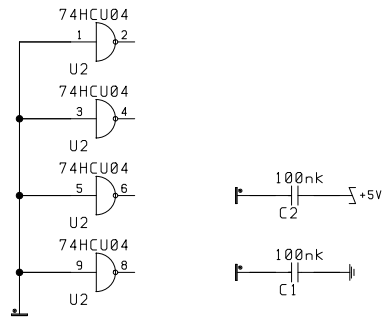
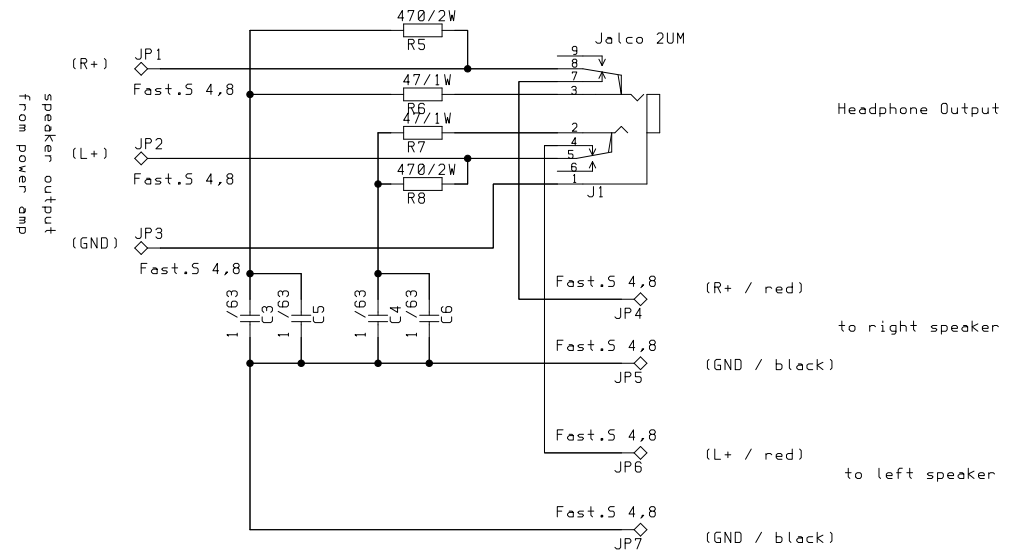
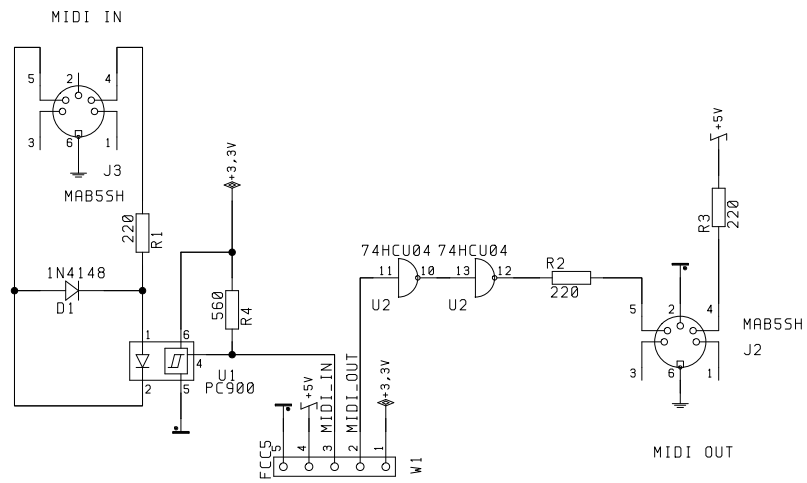

Heides & Kellmann TECHNOLOGY OF TONE		Drawn by: A. Peter
Title: zenAmp MIDI / Headphones		Date: 03-Sep-2001
Filename: HU0100-SP-R04-1A-030901.bsp		Ref.-Nr.: HU0100-SP-R04-1A
Checked by: Alexander Peter		Page: 1 / 2

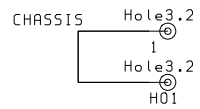
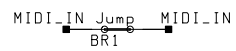

		Drawn by: A. Peter
Title: zenAmp MIDI / Headphones		Date: 03-Sep-2001
Filename: HU0100-SP-R04-1A-030901.big		Ref.-Nr.: HU0100-SP-R04-1A
Checked by: Alexander Peter		Page: 2 / 2

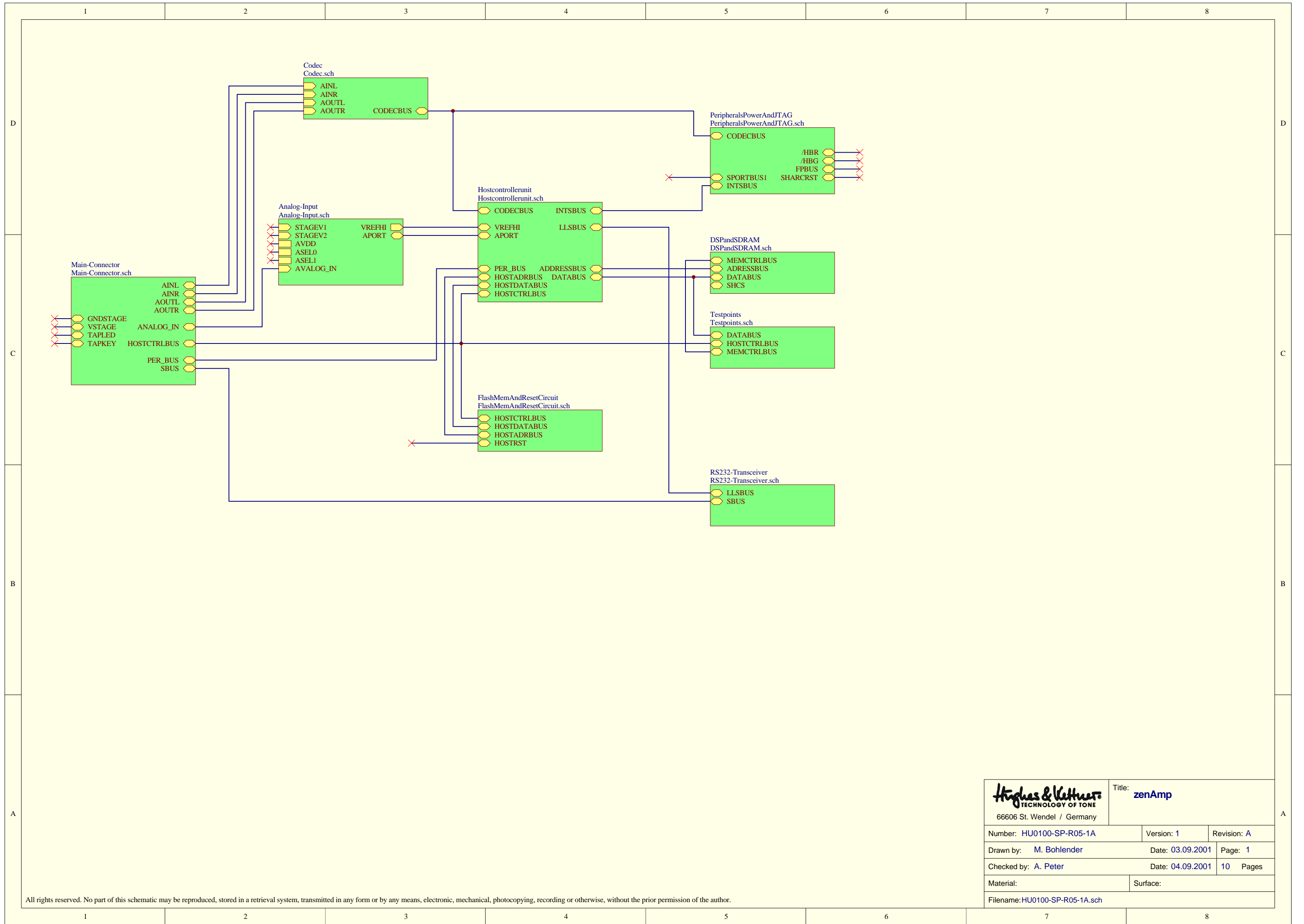

		Title: zenAmp	
66606 St. Wendel / Germany			
Number: HU0100-SP-R05-1A	Version: 1	Revision: A	
Drawn by: M. Bohlender	Date: 03.09.2001	Page: 1	
Checked by: A. Peter	Date: 04.09.2001	10 Pages	
Material:	Surface:		
Filename: HU0100-SP-R05-1A.sch			

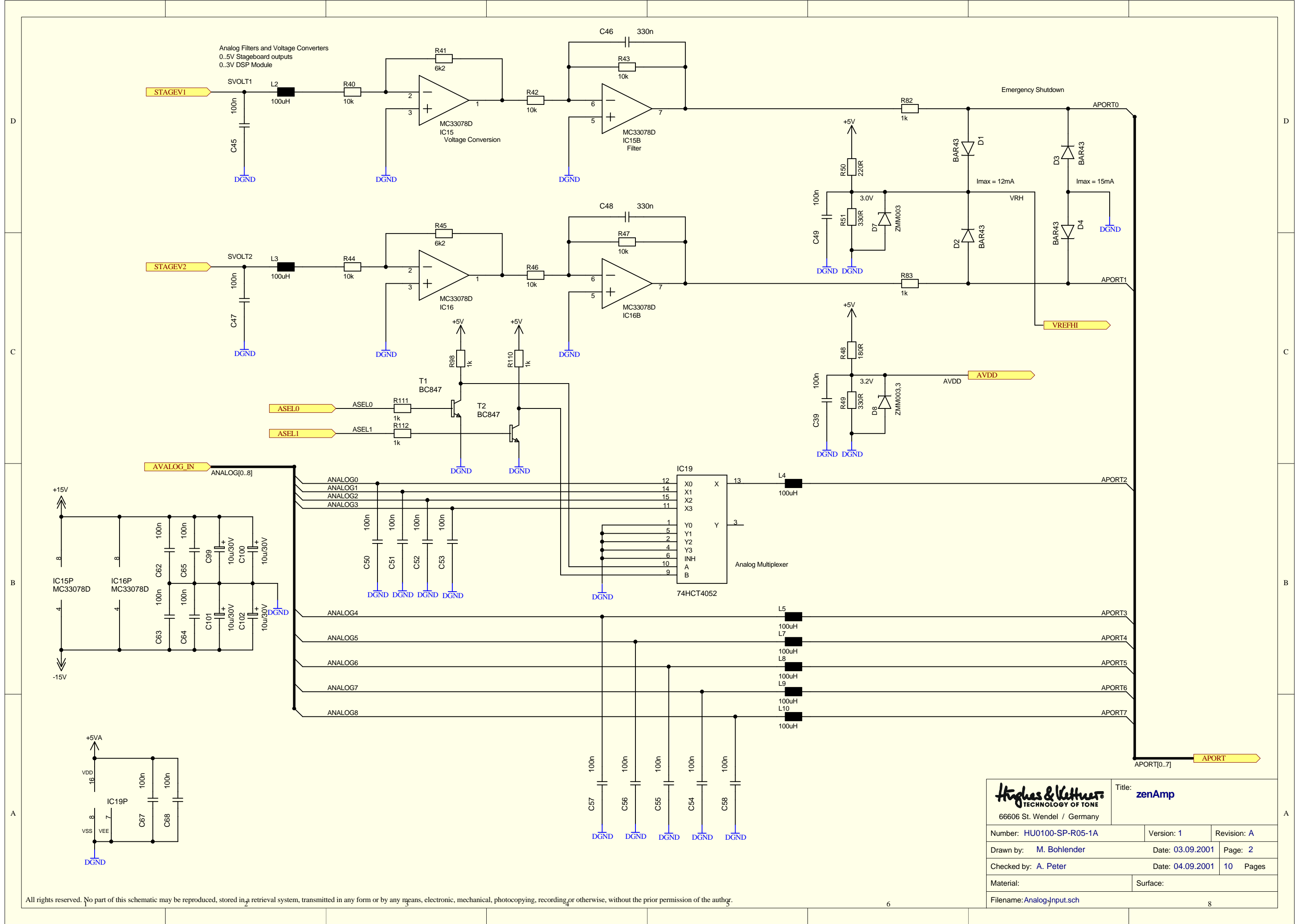

		Title: zenAmp	
66606 St. Wendel / Germany			
Number: HU0100-SP-R05-1A	Version: 1	Revision: A	
Drawn by: M. Bohlander	Date: 03.09.2001	Page: 2	
Checked by: A. Peter	Date: 04.09.2001	10 Pages	
Material:	Surface:		
Filename: Analog-Input.sch			

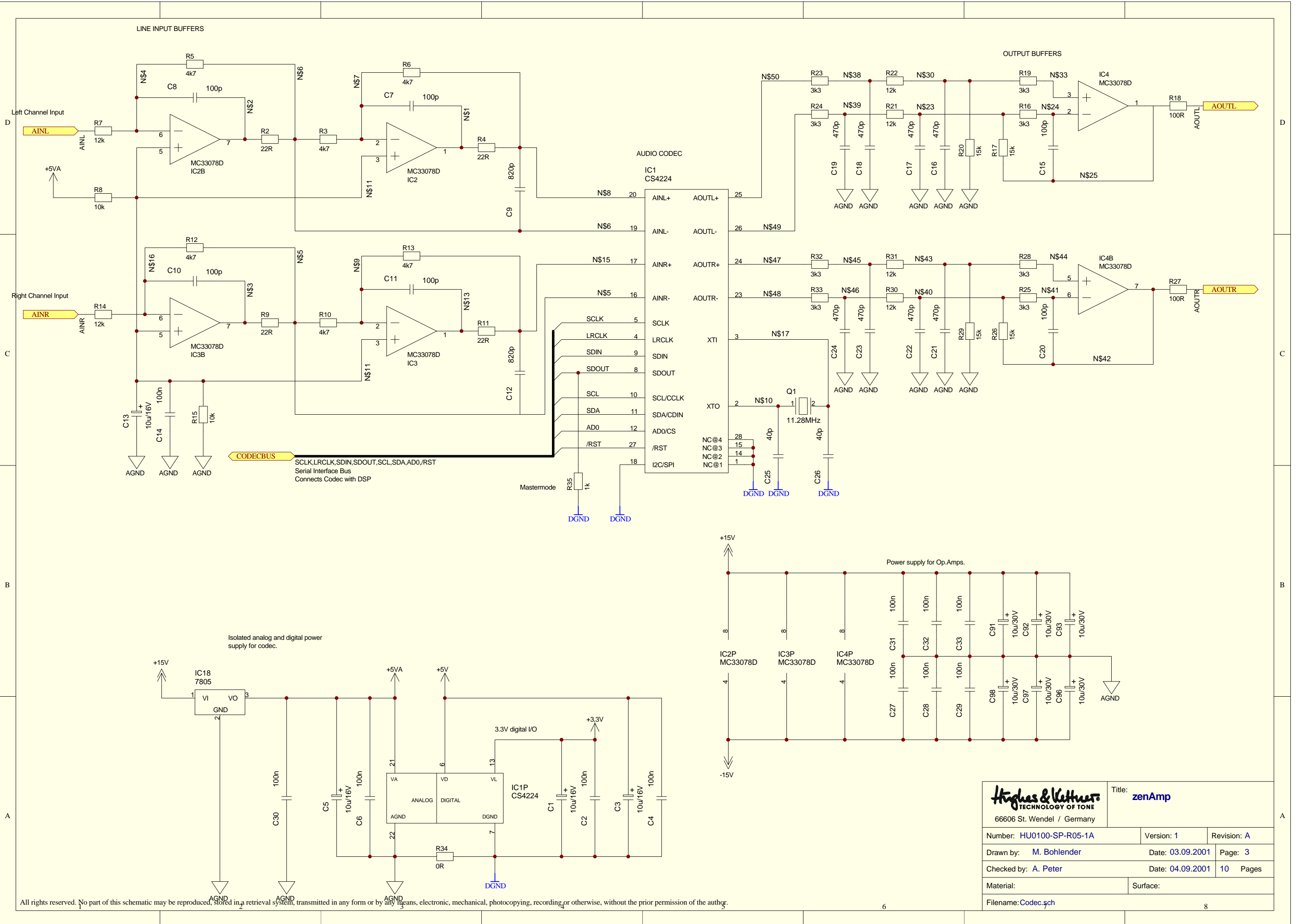

CODECBUS
 SCLK, LRCLK, SDIN, SDOUT, SCL, SDA, AD0, /RST
 Serial Interface Bus
 Connects Codec with DSP

Isolated analog and digital power supply for codec.

		Title: zenAmp	
66606 St. Wendel / Germany			
Number: HU0100-SP-R05-1A	Version: 1	Revision: A	
Drawn by: M. Bohlender	Date: 03.09.2001	Page: 3	
Checked by: A. Peter	Date: 04.09.2001	10 Pages	
Material:	Surface:		
Filename: Codec.sch			

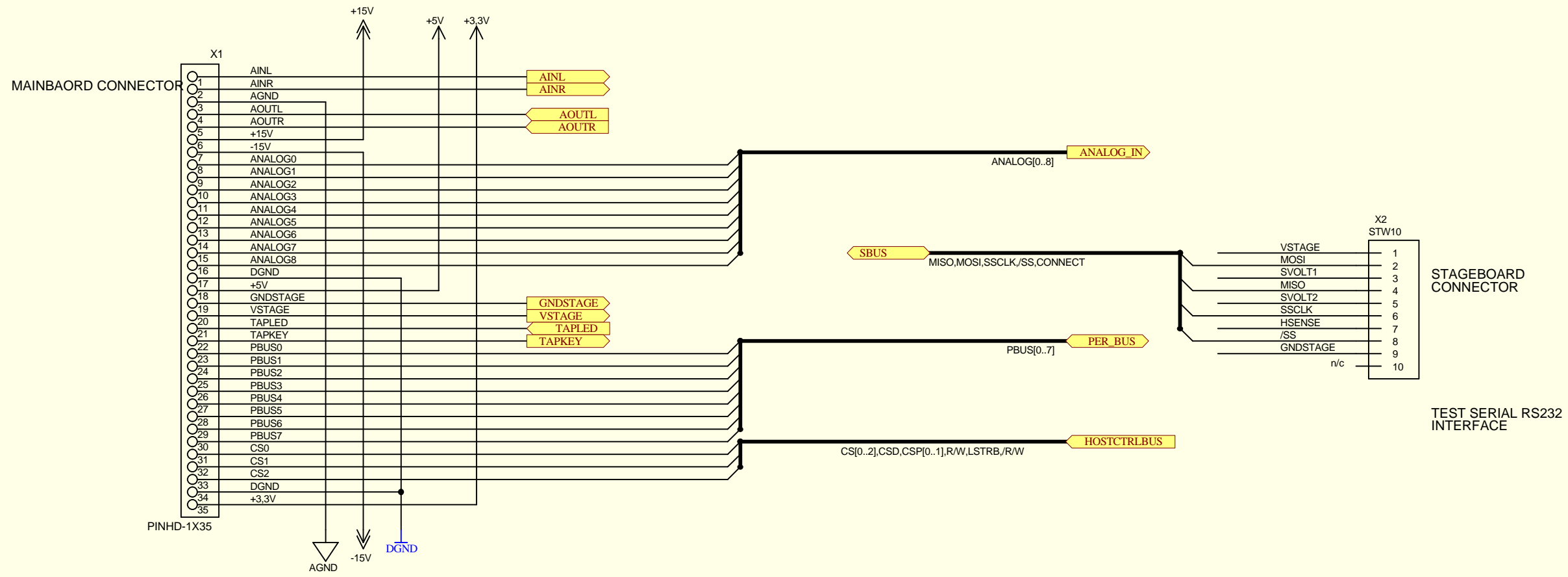

LINEAR -LOW DROP- 3.3V REGULATOR

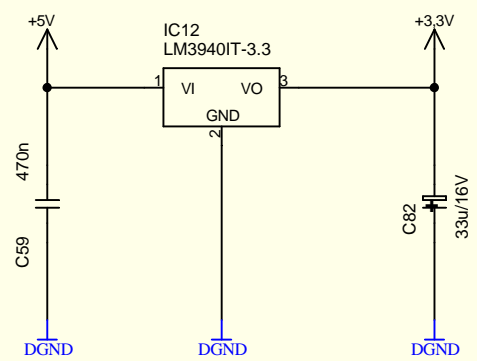

		Title: zenAmp	
66606 St. Wendel / Germany		Number: HU0100-SP-R05-1A	Version: 1
Drawn by: m. Bohlender	Date: 03.09.2001	Page: 4	Revision: A
Checked by: A. Peter	Date: 04.09.2001	10	Pages
Material:	Surface:		
Filename: Main-Connector.sch	8		

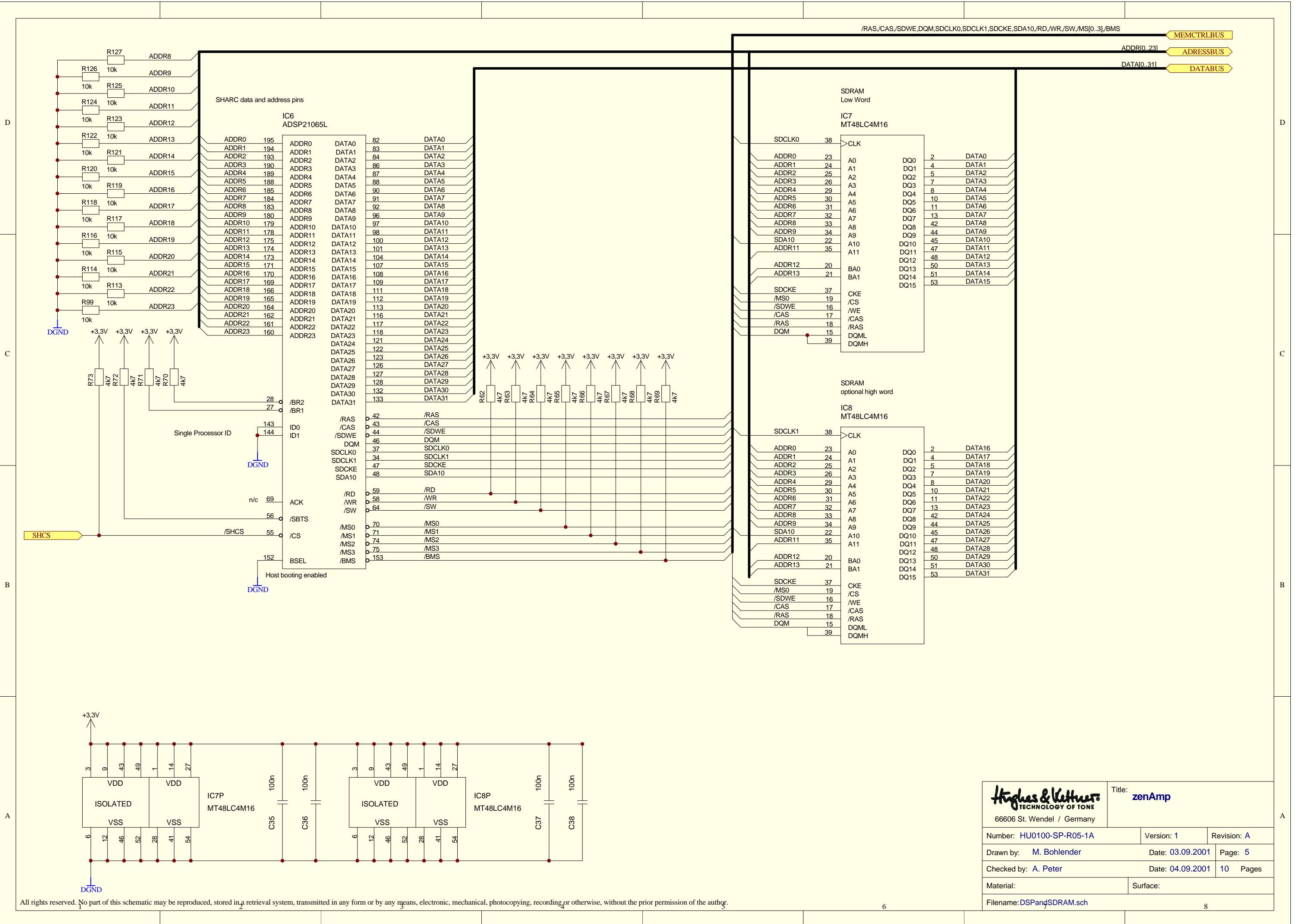

All rights reserved. No part of this schematic may be reproduced, stored in a retrieval system, transmitted in any form or by any means, electronic, mechanical, photocopying, recording or otherwise, without the prior permission of the author.

		Title: zenAmp	
66606 St. Wendel / Germany			
Number: HU0100-SP-R05-1A	Version: 1	Revision: A	
Drawn by: M. Bohlender	Date: 03.09.2001	Page: 5	
Checked by: A. Peter	Date: 04.09.2001	10 Pages	
Material:	Surface:		
Filename: DSPanqSDRAM.sch			

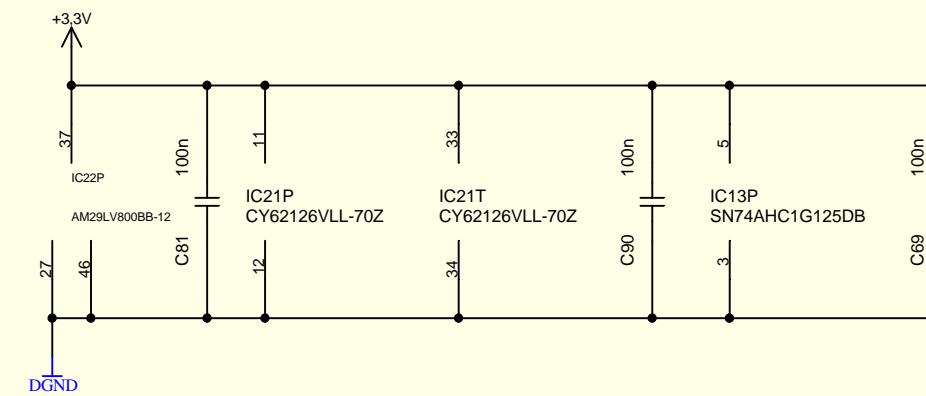
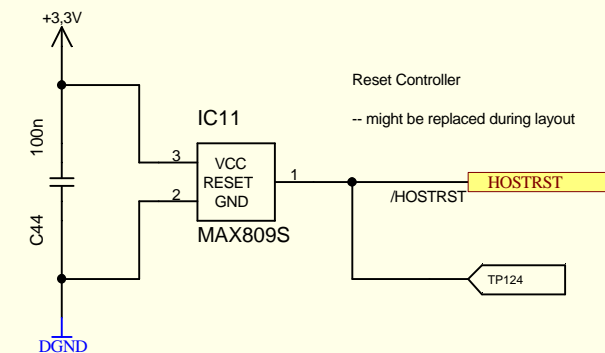
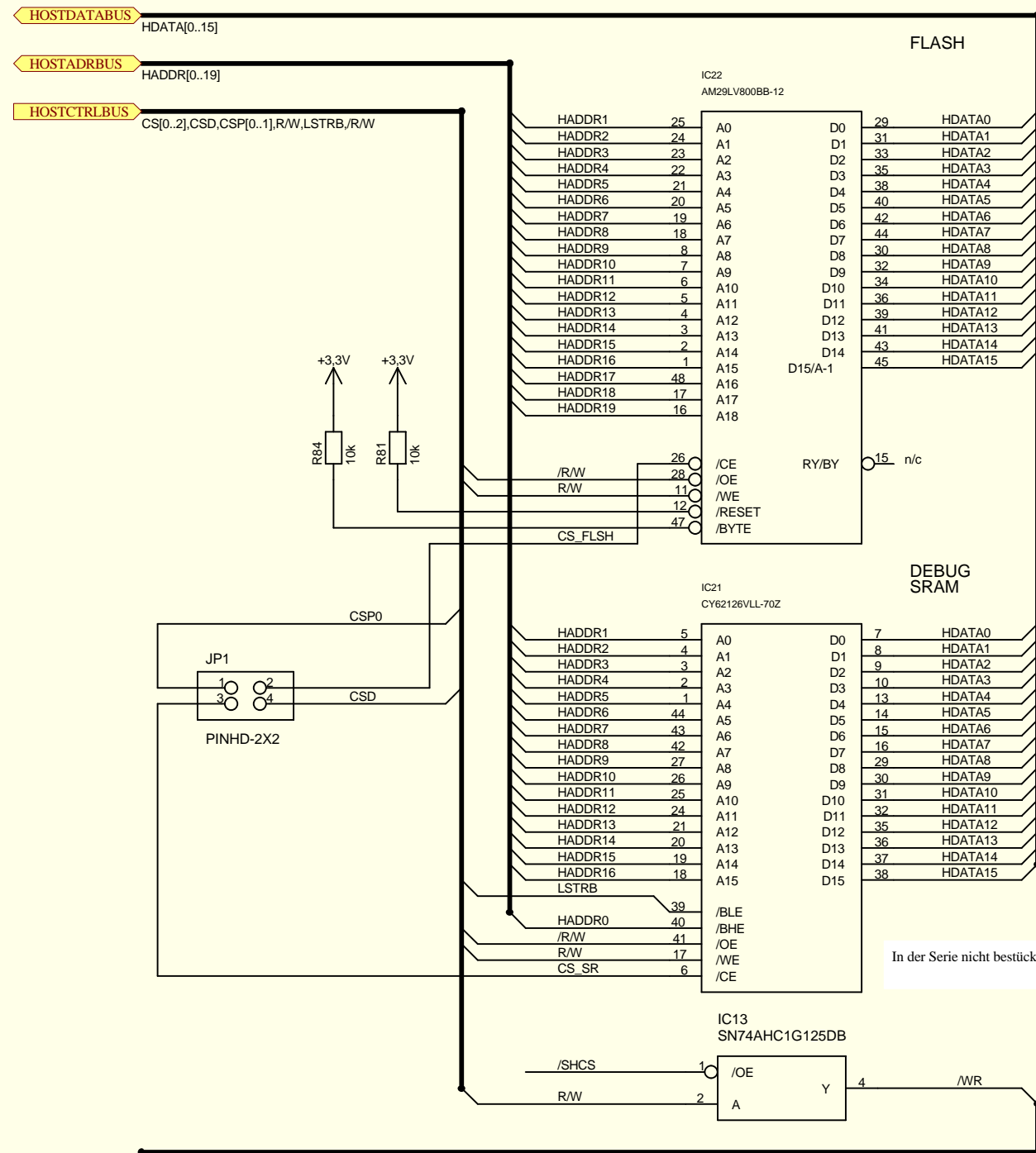

In der Serie nicht bestückt!

		Title: zenAmp	
66606 St. Wendel / Germany			
Number: HU0100-SP-R05-1A	Version: 1	Revision: A	
Drawn by: M. Bohlander	Date: 03.09.2001	Page: 6	
Checked by: A. Peter	Date: 04.09.2001	10 Pages	
Material:	Surface:		
Filename: FlashMemAndResetCircuit.sch			

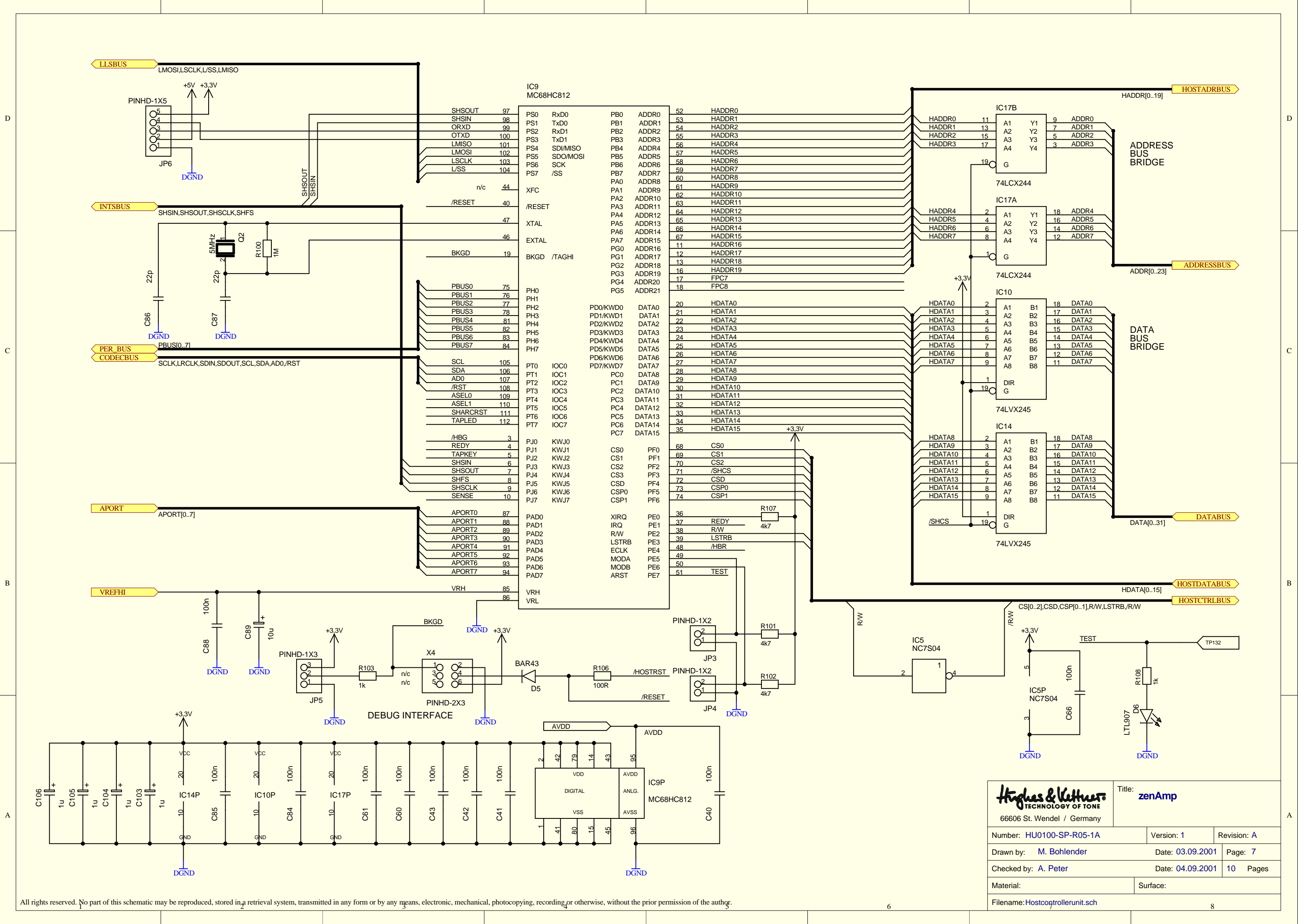

		Title: zenAmp	
66606 St. Wendel / Germany			
Number: HU0100-SP-R05-1A	Version: 1	Revision: A	
Drawn by: M. Bohlender	Date: 03.09.2001	Page: 7	
Checked by: A. Peter	Date: 04.09.2001	10 Pages	
Material:	Surface:		
Filename: Hostcontrollerunit.sch			

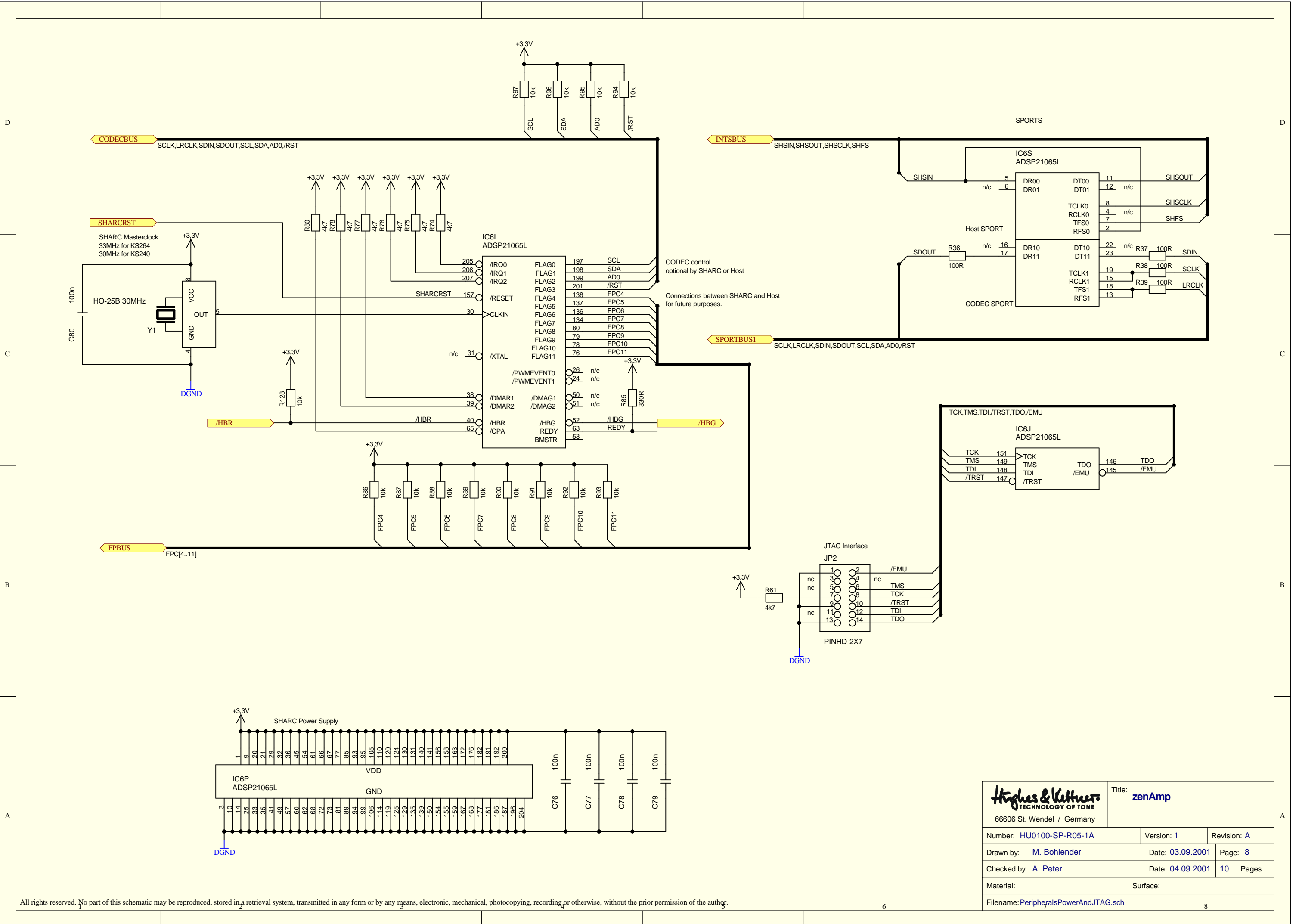

All rights reserved. No part of this schematic may be reproduced, stored in a retrieval system, transmitted in any form or by any means, electronic, mechanical, photocopying, recording, or otherwise, without the prior permission of the author.

		Title: zenAmp	
66606 St. Wendel / Germany			
Number: HU0100-SP-R05-1A	Version: 1	Revision: A	
Drawn by: M. Bohlender	Date: 03.09.2001	Page: 8	
Checked by: A. Peter	Date: 04.09.2001	10 Pages	
Material:	Surface:		
Filename: PeripheralsPowerAndJTAG.sch			

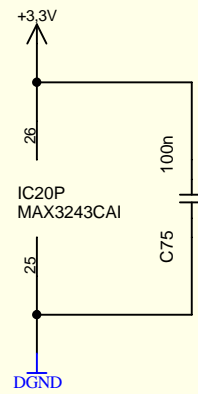
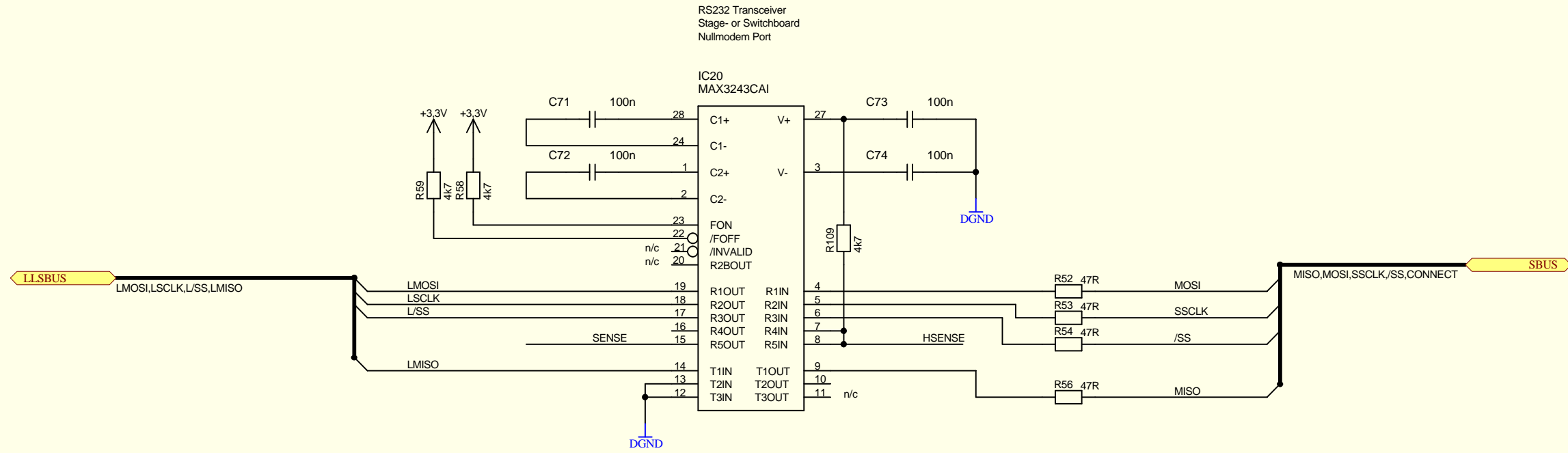

 66606 St. Wendel / Germany		Title: zenAmp	
		Number: HU0100-SP-R05-1A	Version: 1
Drawn by: M. Bohlender		Date: 03.09.2001	Page: 9
Checked by: A. Peter		Date: 04.09.2001	10 Pages
Material:		Surface:	
Filename: RS232-Transceiver.sch			

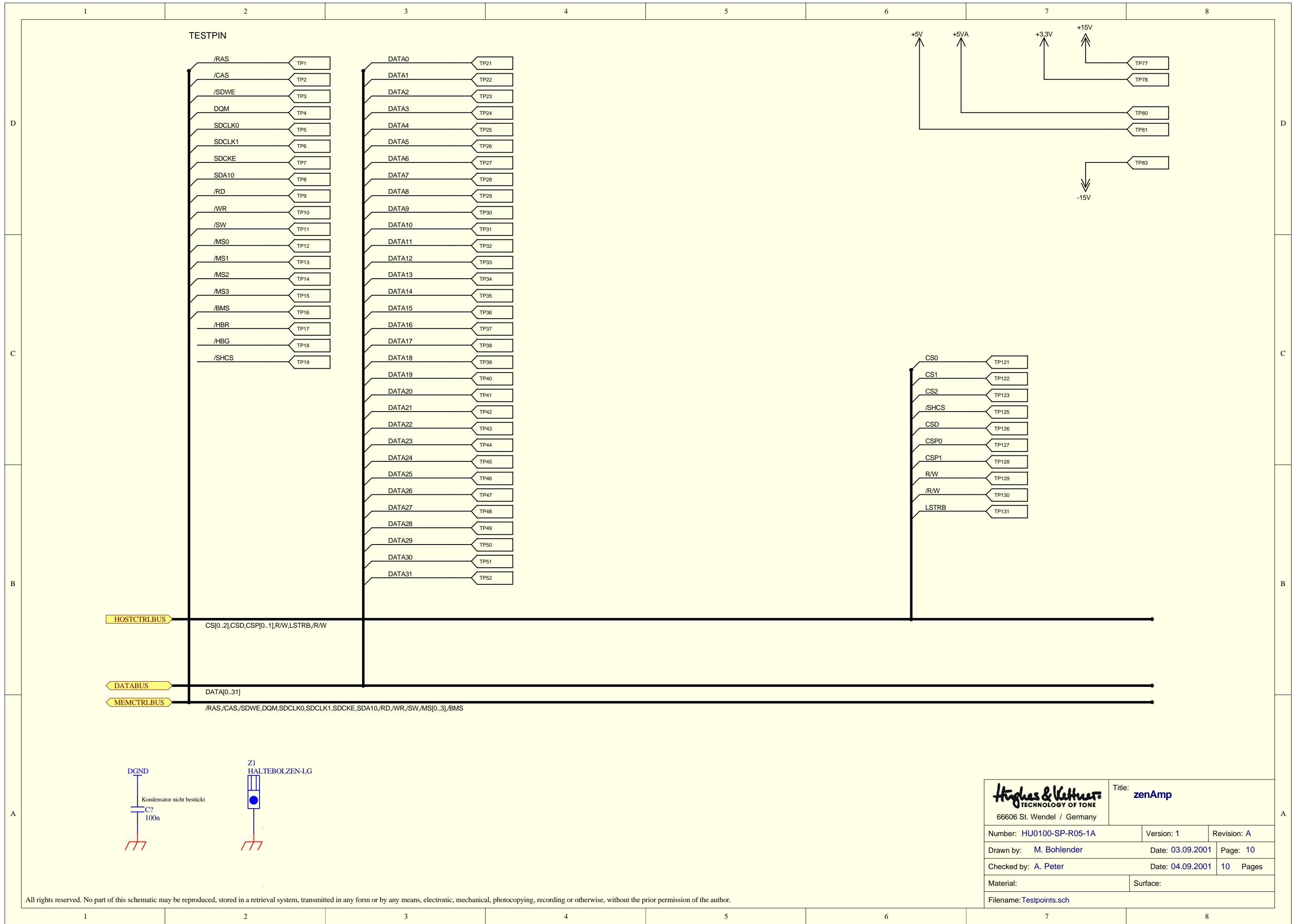

Schurter CE30.6100.151

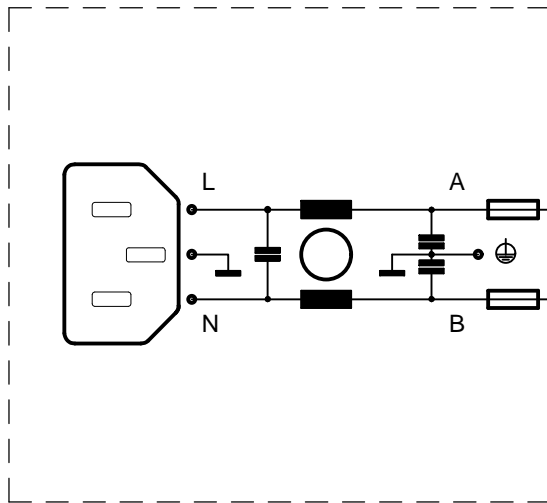

Power Switch

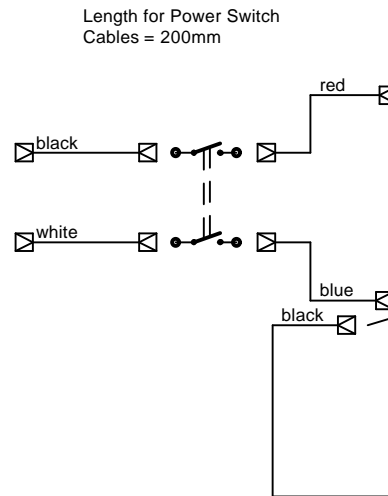

Voltage Selector

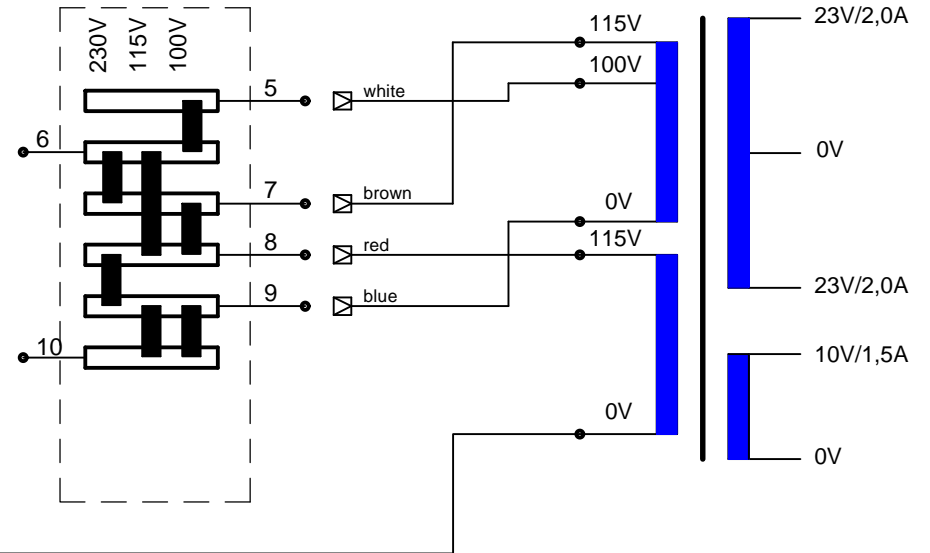

Power Transformer

☒ Faston 4,8mm insulated

☒ Faston 4,8mm insulated, with 2nd 4,8mm pin



Magdeburger Straße 8
66606 St. Wendel
Germany

Title: ZenTrix Power Transformer 100/115/230V wiring		Drawing Number. : ZT_SO01_01	
Drawn: Alexander Peter	Revision: 1	Checked:	Date : 11-May-01

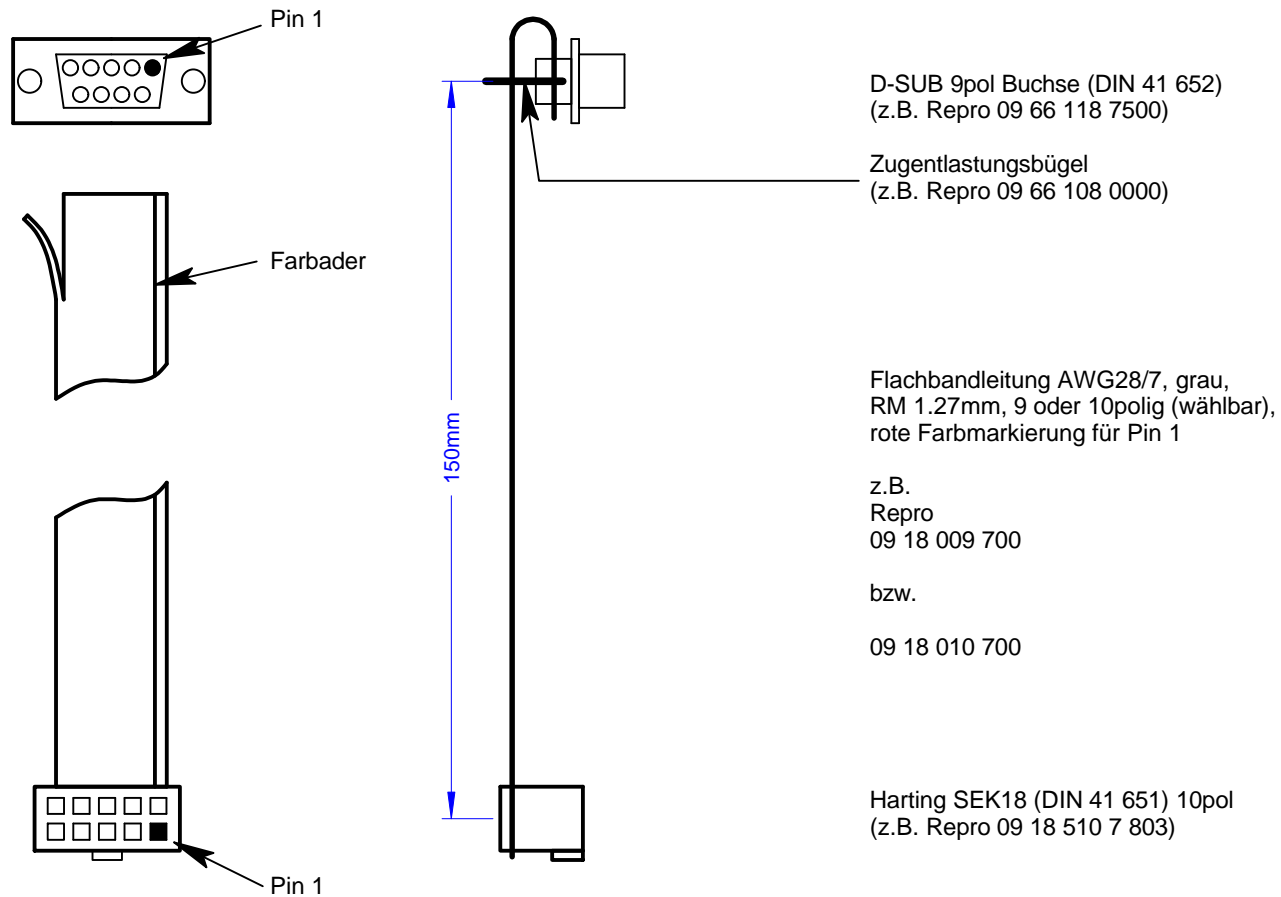

Magdeburger Straße 8
66606 St. Wendel
Germany

Bezeichnung:
Zentrix Stagboardschnittstellenkabel, 9pol DSUB auf 10pol Pfostenfeld

Gezeichnet von:
Alexander Peter

Revision:
1

Geprüft:

Zeichnungsnummer :
ZT_SO02_01

Datum :
11. Mai 2001