

ICEpower 125ASX2

2x125W or 1x500W ICEpower Amplifier
with Integrated Power Supply

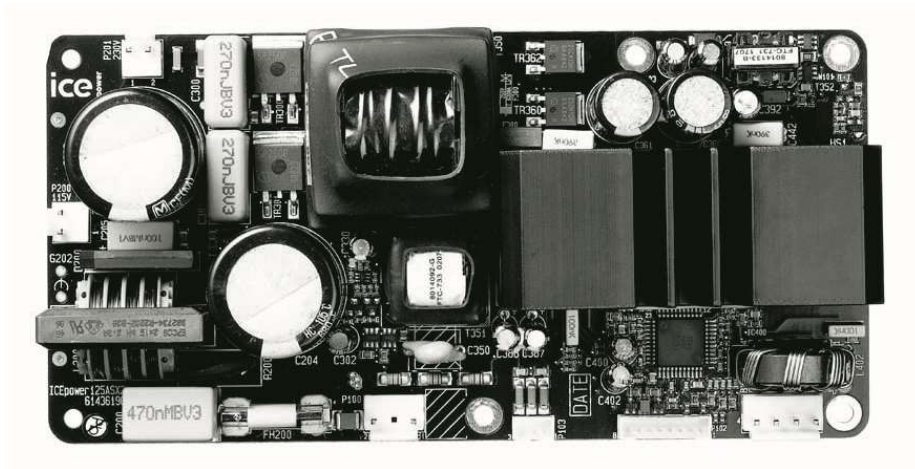

ICEpower 125ASX2

Contents

General Description.....	3
Release Notes	4
Block Diagram	5
Connection Diagram.....	5
Absolute Maximum Ratings.....	7
Power Specifications	9
General Audio Specifications (SE-mode).....	9
General Audio Specifications (BTL-mode).....	10
Electrical Specifications	12
Timing Specifications.....	12
Disturbances on the Mains	12
Mechanical Specifications	12
Typical Performance Characteristics	13
Power vs. Frequency	18
Output Impedance	18
Loading.....	18
Dissipated Power vs. Output Power	19
Features	20
Protection Features	22
Power Supply Protection	22
Amplifier Local Protection.....	23
Amplifier Global Protection	23
Input/Output Interface	23
BTL module setup	24
Output stage.....	24
Operational Timing Diagram.....	25
Thermal Design	25
Physical Dimensions	26
Drill Pattern	28
Safety Standards	29
ESD Warning	29
Packaging and Storing.....	30
Contact	31
Legal Notes.....	31

General Description

The ICEpower125ASX2 is a fully integrated, intelligent audio power conversion solution designed particularly for highly competitive consumer and professional audio products. The ICEpower125ASX2 is EMC and safety approved and the “black-box” completeness allows for fast design-in and minimized time to market. Key benefits include:

- State-of-the-art, high efficiency ICEpower amplification stage based on the patented HCOM modulation and MECC control techniques
- An ICEpower Supply with selectable mains converter and separate aux converter
- A wide set of features for plug-and-play implementation into applications such as active speakers and subwoofers, wireless speakers, multimedia audio, musical instrument amplifiers and distributed audio

The ICEpower125ASX2 can be configured to either stereo or mono output. Combined with the auxiliary supply for powering external circuitry and the complete elimination of external heat sinks and EMI shields, the ICEpower125ASX2 is the natural choice in any audio application that requires a compact, integrated power solution.

The ICEpower125ASX2 is protected against short circuits, overload and overheating and includes on-board fuses and EMI filtering to provide a CE and FCC pre-approved design.

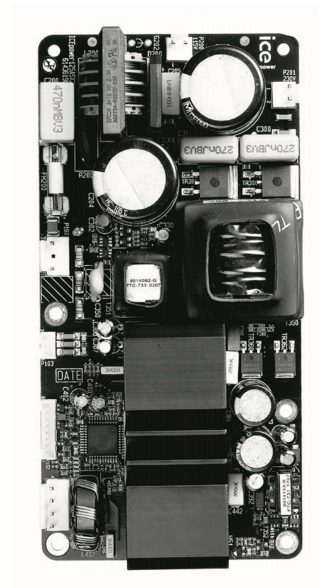

Key Specifications

- 450W @ 1% THD+N, 20Hz – 20kHz, 4Ω, BTL
- 2 x 120W @ 1% THD+N, 20Hz – 20kHz, 4Ω, SE (both channels driven)
- 220W (2Ω) + 58W (8Ω) @ 1% THD+N, 20Hz – 20kHz, SE (both channels driven with asymmetric load)
- Max output voltage / current: 32V_p / 20A_p, 4Ω, SE
- Max output voltage / current: 60V_p / 20A_p, 4Ω, BTL
- 121dBA dynamic range (BTL-mode)
- 117dBA dynamic range (SE-mode)
- THD+N = 0.002% @ 1W (8Ω, 1kHz, SE-mode)
- THD+N = 0.002% @ 1W (8Ω, 1kHz, BTL-mode)
- 86,4 % total efficiency @ 250W, 8Ω
- CCIF Intermodulation distortion = 0.0009%, 10W, 4Ω, 18.5kHz/1kHz
- ±24V unregulated auxiliary power supply
- Selectable Mains 85-132V_{AC} & 170-264V_{AC}

Key Features

- Fully integrated audio power solution
- Rugged construction
- Thermal protection
- Over current protection
- Sound optimized soft clipping
- Suitable for CE approved designs
- EMI conforms to: EN55013
EN55020
EN61000-3-2
EN61000-3-3
FCC part 15-B
- Safety conforms to: IEC/UL 60065

Version 1.9

Release Notes

Version	Date	Revised by	Description
1.2	2014-11-13	LBH/SMK	Asymmetric load
1.3	2015-12-03	LBH	Header spec. text updated
1.4	2017-09-19	DIT	Legal Notes updated
1.5	2018-06-20	LBH/DIT	Output voltage / current spec. added Safety and EMC standards updated
1.6	2018-11-06	LBH/DIT	Absolute maximum Ratings updated
1.7	2018-12-11	LBH/DIT	Table 18 and 19, Dissipated Power vs. Output Power updated
1.8	2019-01-15	LBH/DIT	Thermal Section updated
1.9	2020-05-05	LBH/NKK	Minor update in Safety Standards

Version 1.9

Block Diagram

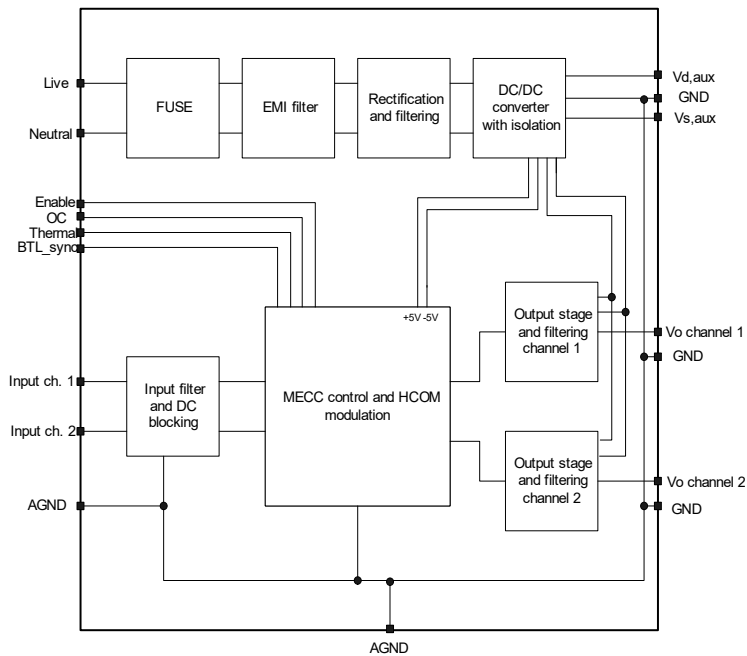

Figure 1: ICEpower125ASX2 block diagram

Connection Diagram

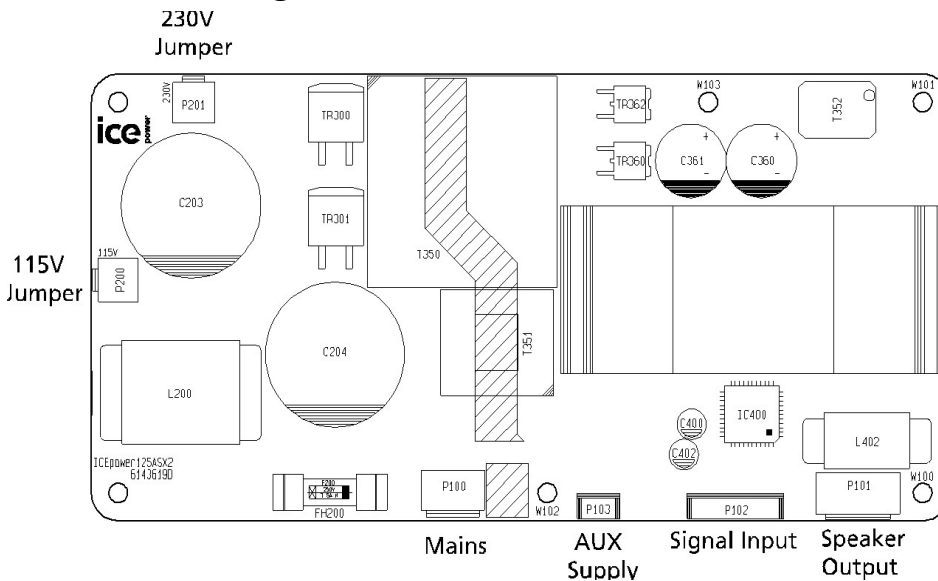

Figure 2: ICEpower125ASX2 connections

The connector interface of the ICEpower125ASX2 module has four industry standard connectors selected for long term reliability.

AC Header Specifications (P100)

Type: JST B2P3-VH			
PIN	Function	Description	Type
1	Neutral	Neutral AC	Input
2	Live	Live AC	Input

Table 1: AC connector specifications.

Speaker Header Specifications (P101)

Type: JST B4P-VH			
PIN	Function	Description	Type
1	Vo+	Amplifier output channel 2	Output
2	GND	GNDchannel2	GND
2	GND	GNDchannel1	GND
4	Vo+	Amplifier output channel 1	Output

Table 2: Speaker connector specifications.

Signal Header Specifications (P102)

Type: JST B8B-PH-K-S			
PIN	Function	Description	Type
1	BTL Sync	Synchronization pin for amplifiers (used in BTL-mode)	Input
2	Enable	Amplifier enable	Input/Output
3	OC	Monitor pin amplifier over current	Output
4	Thermal	Thermal monitoring pin	Output
5	Vin channel 2	Input signal channel 2	Input
6	GND	Ground terminal for the signal section.	GND
7	GND	Ground terminal for the signal section.	GND
8	Vin channel 1	Input signal channel 1	Input

Table 3: Signal connector specifications.

Auxiliary Supply Header Specifications (P103)

Type: JST B3B-PH-K-S			
PIN	Function	Description	Type
1	Vd _{aux}	Positive unregulated auxiliary supply (typical +24V)	Output
2	GND	Ground terminal for the auxiliary section.	GND
3	Vs _{aux}	Negative unregulated auxiliary supply (typical -24V)	Output

Table 4: Auxiliary supply header specifications.

Absolute Maximum Ratings

Absolute maximum ratings indicate limits above which damage may occur.

Mains Input Section

115V mains setting

Symbol	Parameter	Value	Units
AC _{max}	Maximum off-line voltage (Safety test)	132 ^{1b)}	V _{AC}
AC _{min}	Minimum off-line voltage (Safety test)	85 ^{1a, 1b)}	V _{AC}
F	Mains frequency range 85VAC - 132VAC	45 – 65	Hz

Table 6: Absolute maximum ratings, mains input section - 115V setting.

230V mains setting

Symbol	Parameter	Value	Units
AC _{max}	Maximum off-line voltage (Safety test)	264 ^{1c)}	V _{AC}
AC _{min}	Minimum off-line voltage (Safety test)	170 ^{1a, 1c)}	V _{AC}
F	Mains frequency range 170V _{AC} - 264V _{AC}	45 – 65	Hz

Table 7: Absolute maximum ratings, mains input section - 230V setting.

1.a) The ICEpower125ASX2 will operate at lower levels but the output power will be reduced. If the off-line voltage is too low, the ICEpower125ASX2 switches off.

1.b) 115 V mains setting: The maximum operating/usage mains voltage is 120Vac and the minimum operating/usage mains voltage is 100Vac.

1.c) 230 V mains setting: The maximum operating/usage mains voltage is 240Vac and the minimum operating/usage mains voltage is 200Vac.

Auxiliary Supply

Symbol	Parameter	Value	Unit
I _{Vd}	Maximum current draw from Vd (+24V) ²⁾	250	mA
I _{Vs}	Maximum current draw from Vs (-24V) ²⁾	-250	mA

Table 8: Absolute maximum ratings, auxiliary supply.

2) If the auxiliary supply on ICEpower125ASX2 is used with a capacitive load, please remember to read the section "Capacitive Loading of the AUX Supply" in the ICEpower125ASX2 designer's manual.

Input Section

Symbol	Parameter	Value	Unit
Vin channel 1 , Vin channel 2	Maximum voltage range on pin	±3.3	Vp

Table 9: Absolute maximum ratings, input section.

Output Section

Symbol	Parameter	Value	Units
Rload	Minimum symmetric load (SE-mode)	3	Ω
	Minimum asymmetric load (SE-mode) ³⁾	2 & 6	Ω
	Minimum load (BTL-mode)	3	Ω
Iout ⁴⁾	Maximum current draw from amplifier output	30	A
CL	Maximal purely capacitive load (SE)	390	nF
	Maximal purely capacitive load (BTL)	220	nF

Table 10: Absolute maximum ratings, output section.

3) The amplifier can be loaded asymmetrically. One channel can be loaded with minimum 2Ω. The other channel must then be minimum 6Ω

4) The overcurrent protection will act to protect the amplifier. (See "Protection features")

Thermal Section

Symbol	Parameter	Value	Unit
T _a	Max ambient temperature, operating – active cooled with fan ^{5a)}	50	°C
T _a	Max ambient temperature, operating – passive cooled, no fan ^{5b)}	45	°C

Table 11: Absolute maximum ratings, thermal section.

5a) For safety test at 50°C ambient with fan and with the module mounted vertical and maximum AUX current draw, the maximum continuous output power without thermal shutdown is 62,5 W in BTL mode (1/8 of 500 W).

5b) For safety test at 45°C ambient without fan and with the module mounted vertical and maximum AUX current draw, the maximum continuous output power without thermal shutdown is 2x16,25 W in SE mode (1/8 of 2x130 W).

Power Specifications

Unless otherwise specified. $T_a=25^\circ\text{C}$, $f=1\text{kHz}$, $R_L=4\Omega$, 230V mains

Symbol	Parameter	Conditions	Min	Typ	Max	Units
t_{pmax}	Time of maximum rated output power ⁶⁾	400W out. No preheating.	-	80	-	s
P_T	Continuous output power ⁶⁾ without thermal shutdown. (SE, 4Ω)	Thermal stab. @ $T_a = 25^\circ\text{C}$. Both channels driven	-	65	-	W
P_T	Continuous output power ⁶⁾ without thermal shutdown. (SE, 8Ω)	Thermal stab. @ $T_a = 25^\circ\text{C}$. Both channels driven	-	70	-	W
P_T	Continuous output power ⁶⁾ without thermal shutdown. (BTL, 4Ω)	Thermal stab. @ $T_a = 25^\circ\text{C}$.	-	70	-	W
P_T	Continuous output power ⁶⁾ without thermal shutdown. (BTL, 8Ω)	Thermal stab. @ $T_a = 25^\circ\text{C}$.	-	200	-	W
P_{SMPS}	Quiescent power consumption (amplifier disabled)	Enable pin low	-	6	-	W
P_q	Quiescent power consumption (amplifier enabled)	$P_o = 0\text{W}$	-	9,5	-	W
η	Total power efficiency	$P_o = 100\text{W } 4 \text{ ohm}$ $P_o = 400\text{W } 4 \text{ ohm}$ $P_o = 500\text{W } 4 \text{ ohm}$ $P_o = 250\text{W } 8 \text{ ohm}$	-	75 80,4 81,4 86,4	-	%
$V_{d_{aux}}$, $V_{s_{aux}}$	Nominal DC voltage	Mains voltage and output power within specified ranges	$\pm 16,5$	± 24	± 28	V

Table 12: Power specifications.

6) The module is mounted vertically in free air.

General Audio Specifications (SE-mode)

Unless otherwise specified, $f=1\text{kHz}$, $P_o=1\text{W}$, $T_a=25^\circ\text{C}$.

Symbol	Parameter	Conditions	Min	Typ	Max	Units
P_o	Output power @ 1%THD+N $20\text{Hz} < f < 20\text{kHz}$, both channels driven. (AES17 measurement filter) ⁸⁾	$R_L = 4\Omega$ $230V_{ac} / 50\text{Hz}$, $115V_{ac} / 50\text{Hz}$	- -	120 105	- -	W
P_o	Output power @ 1%THD+N $20\text{Hz} < f < 20\text{kHz}$, both channels driven, First channel $R_L = 2.7\Omega$, Second channel $R_L = 8\Omega$ (AES17 measurement filter) ⁸⁾	$230V_{ac} / 50\text{Hz}$, $R_L = 2.7\Omega$ $R_L = 8\Omega$ $115V_{ac} / 50\text{Hz}$, $R_L = 2.7\Omega$ $R_L = 8\Omega$	- - - -	175 60 160 58	- - - -	W
P_o	Output power @ 1%THD+N $20\text{Hz} < f < 20\text{kHz}$, both channels driven, First channel $R_L = 2\Omega$,	$230V_{ac} / 50\text{Hz}$, $R_L = 2\Omega$ $R_L = 8\Omega$	- -	220 58	- -	W

	Second channel $R_L = 8\Omega$ (AES17 measurement filter) ⁸⁾	$115V_{ac} / 50Hz$, $R_L = 2\Omega$ $R_L = 8\Omega$	- -	210 55	- -	
P_O	Output power @ 10%THD+N $20Hz < f < 20kHz$, both channels driven. (AES17 measurement filter) ⁸⁾	$R_L = 4\Omega$ $230V_{ac} / 50Hz$, $115V_{ac} / 50Hz$	- -	150 130	- -	W
P_O	Output power @ 1%THD+N $20Hz < f < 20kHz$, one channel driven. (AES17 measurement filter) ⁸⁾	$R_L = 4\Omega$ $230V_{ac} / 50Hz$, $115V_{ac} / 50Hz$	- -	130 120	- -	W
P_O	Output power @ 1%THD+N $20Hz < f < 20kHz$, one channel driven. (AES17 measurement filter) ⁸⁾	$R_L = 2.7\Omega$ $230V_{ac} / 50Hz$, $115V_{ac} / 50Hz$	- -	185 175	- -	W
P_O	Output power @ 1%THD+N $20Hz < f < 20kHz$, one channel driven. (AES17 measurement filter) ⁸⁾	$R_L = 2\Omega$ $230V_{ac} / 50Hz$, $115V_{ac} / 50Hz$	- -	230 220	- -	W
V_{O-max}	Max output voltage	$R_L = 4\Omega$	-	32	-	V_p
I_{O-max}	Max output current	(output current limited)	-	20	-	A_p
THD+N	THD+N (4Ω , AES17 measurement filter) ⁸⁾	$f = 100Hz$, $P_O = 1W$	-	0.003	0.01	%
$V_{N,o}$	Output referenced idle noise	A-weighted	20	30	80	μV
A_v	Nominal Voltage Gain	$f = 1 kHz$	24,3	24,8	25,3	dB
f	Frequency response	$20Hz - 20kHz$, All loads	-	± 0.15	± 0.5	dB
f_u	Upper bandwidth limit (SE) (-3dB)	$R_L = 8\Omega$ $R_L = 4\Omega$	- -	120 90	- -	kHz kHz
f_l	Lower bandwidth limit (-3dB)	$R_L = \text{All loads}$	-	1.5	-	Hz
Z_o	Abs. output impedance	$f = 1kHz$	-	18	25	$m\Omega$
Z_L	Load impedance range		3 ⁷⁾	4	∞	Ω
D	Dynamic range	A-weighted ($125W$, 4Ω)	-	117	-	dB
IMD	Intermodulation (CCIF)	$f = 18.5kHz$, $1kHz$, $P_O = 10W$	-	0.0009	-	%
TIM	Transient intermodulation (DIM30)	$P_O = 10W$	-	0.007	-	%

Table 13: General audio specifications.

7) The amplifier can be loaded asymmetrically. One channel can be loaded with minimum 2Ω . The other channel must then be minimum 6Ω

8) An Audio Precision AES17 20 kHz 7th order measurement filter is used for measurements. The frequency 6.67 kHz corresponds to the worst-case scenario where both 2nd and 3rd harmonics are within the audio band.

General Audio Specifications (BTL-mode)

Unless otherwise specified, $f = 1kHz$, $P_O = 1W$, $T_a = 25^\circ C$.

Symbol	Parameter	Conditions	Min	Typ	Max	Units
P_O	Output power @ 1%THD+N $20Hz < f < 20kHz$ (AES17 measurement filter) ⁸⁾	$R_L = 4\Omega$ $230V_{ac} / 50Hz$, $115V_{ac} / 50Hz$	- -	450 370	- -	W

Version 1.9

P_O	Output power @ 10%THD+N 20Hz < f < 20kHz (AES17 measurement filter) ⁸⁾	$R_L = 4\Omega$ 230V _{ac} /50Hz, 115V _{ac} /50Hz	- -	550 450	- -	W
V_{O-max}	Max output voltage	$R_L = 4\Omega$	-	60	-	V _p
I_{O-max}	Max output current	(output current limited)	-	20	-	A _p
THD+N	THD+N in 4Ω (AES17 measurement filter) ⁸⁾	f = 100Hz, P _O =1W	-	0.003	0.005	%
$V_{N,O}$	Output referenced idle noise	A-weighted 20Hz < f < 20kHz	25	35	80	μV
A_V	Nominal Voltage Gain	f = 1 kHz	29,7	30,7	31,7	dB
f	Frequency response	20Hz - 20kHz, All loads	-	±0.3	±0.7	dB
f_u	Upper bandwidth limit (BTL) (-3dB)	$R_L = 8\Omega$ $R_L = 4\Omega$	- -	100 70	- -	kHz kHz
f_l	Lower bandwidth limit (-3dB)	$R_L = \text{All loads}$	-	1.5	-	Hz
Z_o	Abs. output impedance	f = 1kHz	-	18	30	mΩ
Z_L	Load impedance range		3	4	∞	Ω
D	Dynamic range	A-weighted at 500W@4Ω	-	121	-	dB
IMD	Intermodulation (CCIF)	f =18.5kHz, 1kHz, P _O =10W	-	0.0003	-	%
TIM	Transient intermodulation (DIM30)	P _O =10W	-	0.006	-	%

Table 14: General audio specifications.

8) An Audio Precision AES17 20 kHz 7th order measurement filter is used for measurements. The frequency 6.67 kHz corresponds to the worst-case scenario where both 2nd and 3rd harmonics are within the audio band.

Electrical Specifications

Unless otherwise specified, $T_a=25^{\circ}\text{C}$.

Symbol	Parameter	Conditions	Min	Typ	Max	Unit
f_o	Switching frequency channel 1	Idle	490	540	590	kHz
f_o	Switching frequency channel 2	Idle	450	500	550	kHz
f_o	Switching frequency BTL	Idle	490	540	590	kHz
f_s	Switching frequency range (amplifier)	Idle to full scale	90	-	590	kHz
f_{smps}	Switching frequency (power supply)		-	100	-	kHz

Table 15: Electrical specifications.

Timing Specifications

Symbol	Parameter	Conditions	Min	Typ	Max	Unit
t_{acd}	Power supply start-up delay. (nominal mains)	Time from reaching AC_{min} to all power supplies are good and amplifier is active.	-	600	1000	ms

Table 16: Timing specifications.

Disturbances on the Mains

The signal on the mains connection is often very noisy and large surge voltages are present. The ICEpower125ASX2 is equipped with mains filtering to suppress surges and noise.

Special care and component selection has made the ICEpower125ASX2 able to withstand surges up to 8kV to avoid damage to the ICEpower125ASX2 in case of surges caused by lightning.

Mechanical Specifications

The ICEpower125ASX2 has passed tough mechanical tests during development to ensure high reliability.

Test	Acceleration	Amount
Unpowered tests: The unit is powered after the test to verify functionality.		
Random vibration	$2g_{RMS}$	3x20min
Bump	10g/16ms, 2-4 Hz	1000 bumps in each of 6 directions ⁹⁾
Shock	70g/12ms	3 shocks in each of 6 directions ⁹⁾
Powered tests: The unit is tested with power applied.		
Sinusoidal vibrations	2.5mm, 5-10Hz 1g, 10-100Hz	2 hours in each of 3 directions ⁹⁾
Random vibrations	0.01g, 10-20Hz $0.7g_{RMS}$ -3dB/oct, 20-150Hz	2 hours in each of 3 directions ⁹⁾

Table 17: Mechanical tests.

9) 6 directions: (up, down, left, right forward and backward). 3 directions: (up and down, left and right, forward and backward)

Typical Performance Characteristics

Frequency Response (SE-mode)

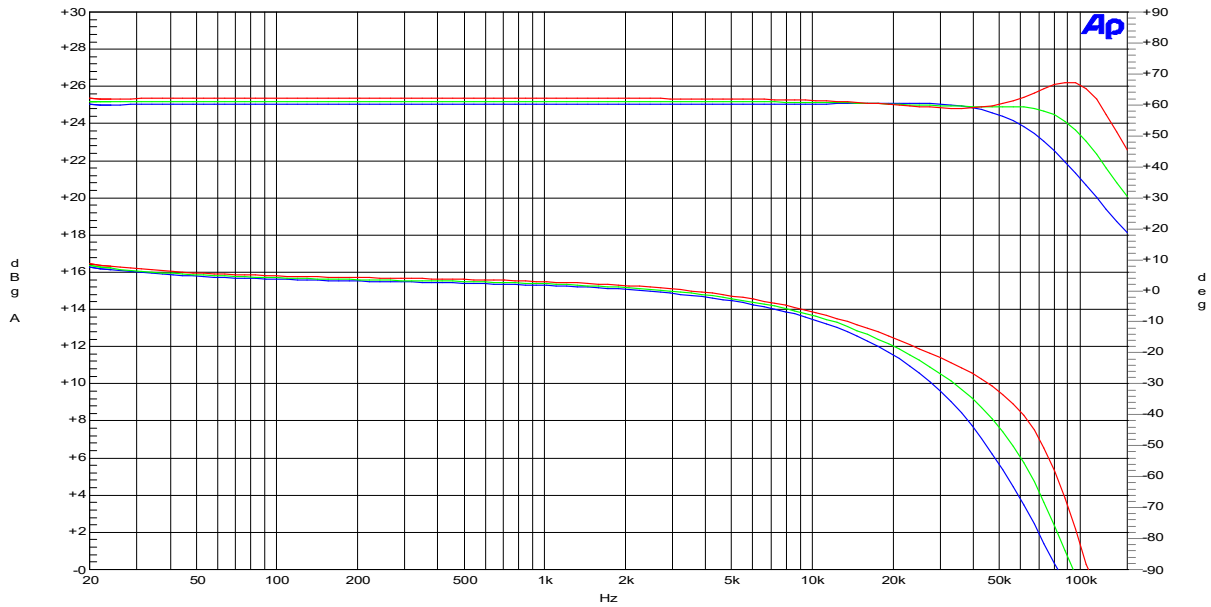

Figure 3: Frequency response in 4Ω (blue), 8Ω (green) and open load (red). Top – amplitude. Bottom – phase.

Frequency Response (BTL-mode)

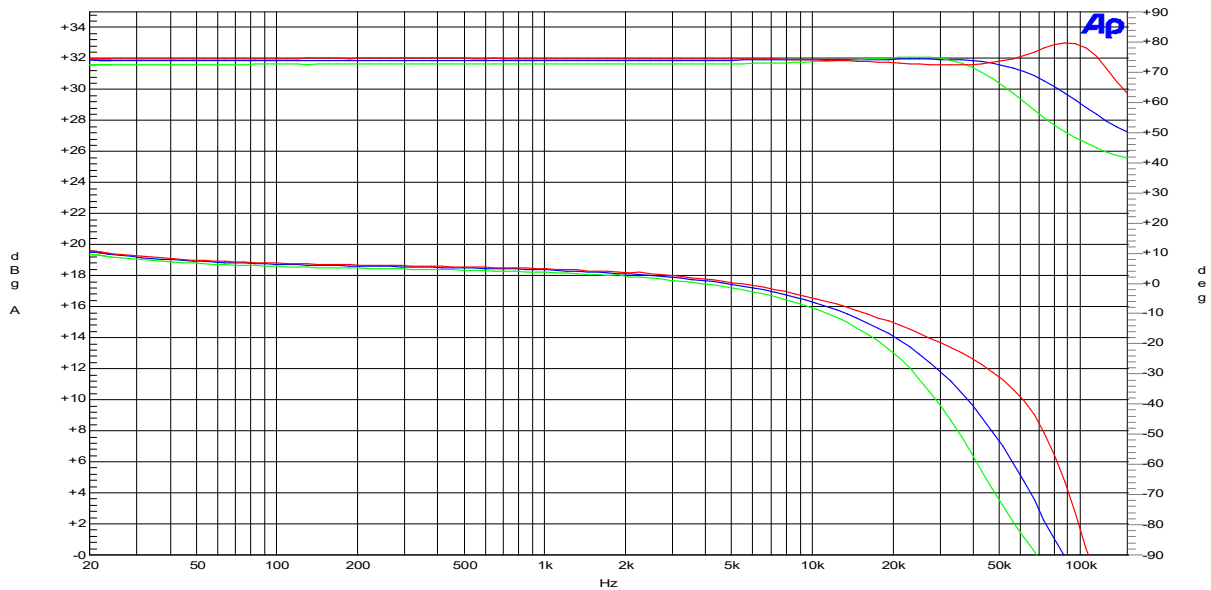
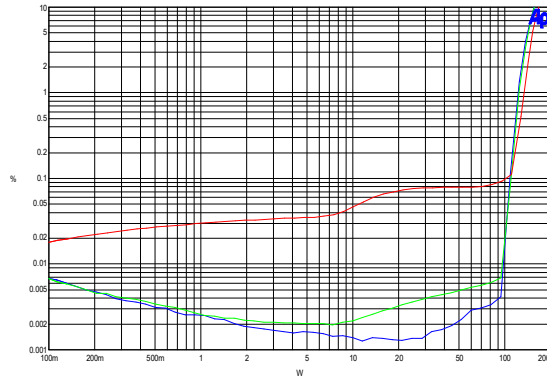
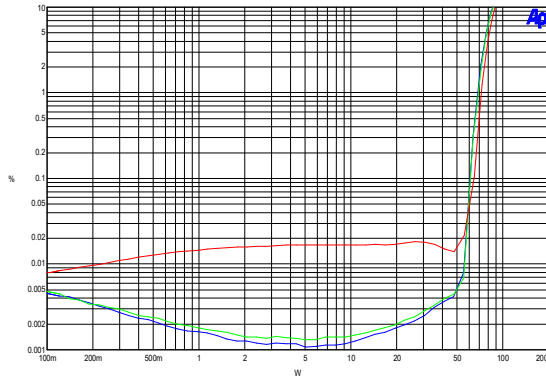

Figure 4: Frequency response in 4Ω (blue), 8Ω (green) and open load (red). Top – amplitude. Bottom – phase.

Version 1.9

Harmonic Distortion & Noise (SE-mode)



THD+N vs. Po at 100Hz, 1kHz and 6.67kHz 8 (8Ω), 230Vac/50Hz

THD+N vs. Po at 100Hz, 1kHz and 6.67kHz 8 (4Ω), 230Vac/50Hz

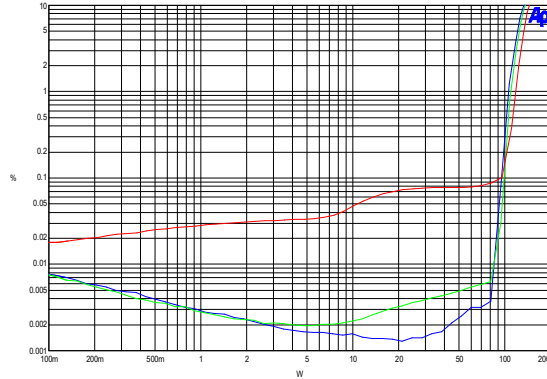
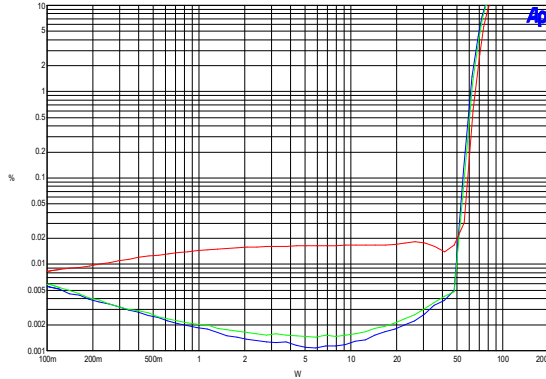

THD+N vs. Po at 100Hz, 1kHz and 6.67kHz⁸⁾ (8Ω), 115Vac/50Hz

THD+N vs. Po at 100Hz, 1kHz and 6.67kHz⁸⁾ (4Ω), 115Vac/50Hz

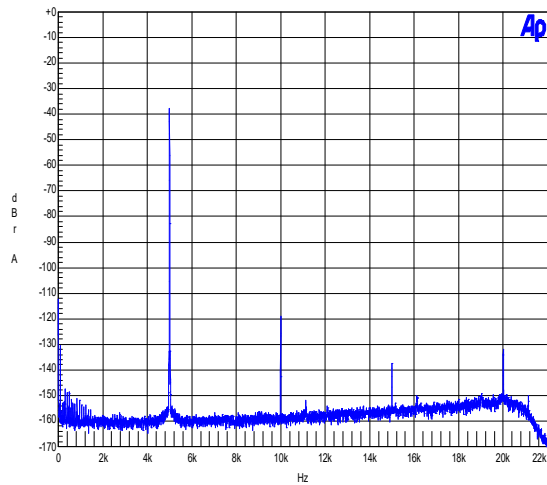
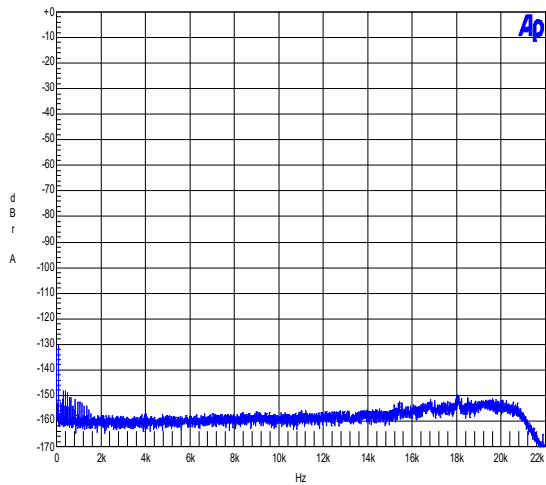

Idle noise (16K FFT). Residual = 30µV(A).
(Relative to 125W into 4 ohm)

f = 5kHz. Po = 100mW. 4Ω loading.
(Relative to 125W into 4 ohm)

Figure 5: Total harmonic distortion & noise (SE).

8) An Audio Precision AES17 20 kHz 7th order measurement filter is used for measurements. The frequency 6.67 kHz corresponds to the worst-case scenario where both 2nd and 3rd harmonics are within the audio band.

Version 1.9

Harmonic Distortion & Noise (BTL-mode)

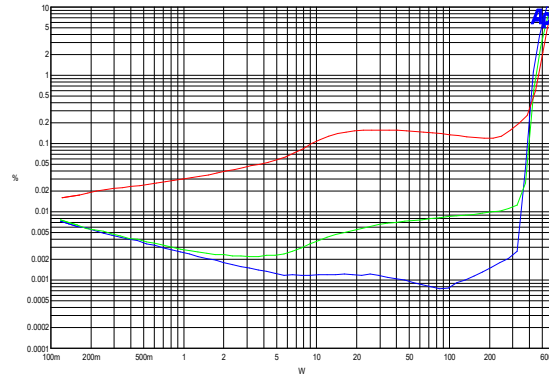
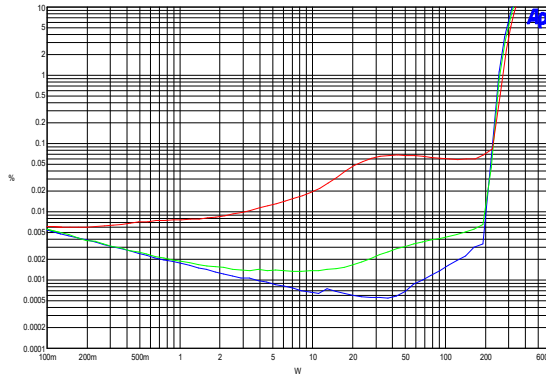

THD+N vs. Po at 100Hz, 1kHz and 6.67kHz⁸⁾ (8Ω), 230Vac/50Hz

THD+N vs. Po at 100Hz, 1kHz and 6.67kHz⁸⁾ (4Ω), 230Vac/50Hz

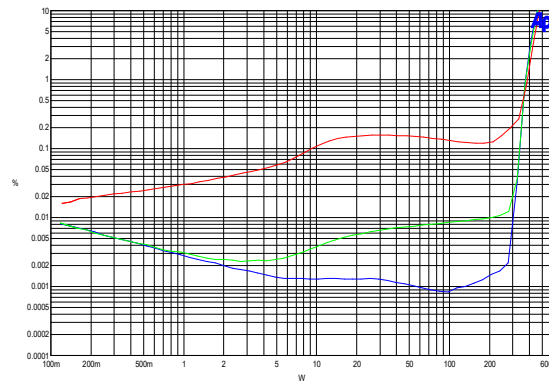
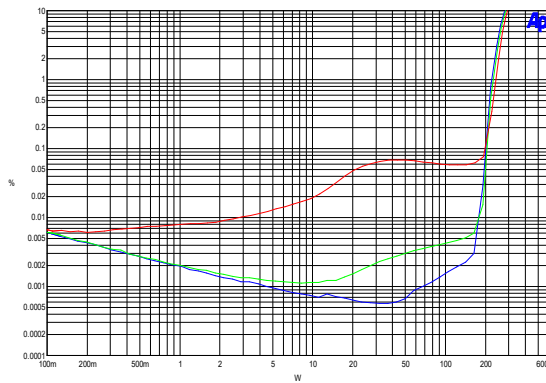

THD+N vs. Po at 100Hz, 1kHz and 6.67kHz⁸⁾ (8Ω), 115Vac/50Hz

THD+N vs. Po at 100Hz, 1kHz and 6.67kHz⁸⁾ (4Ω), 115Vac/50Hz

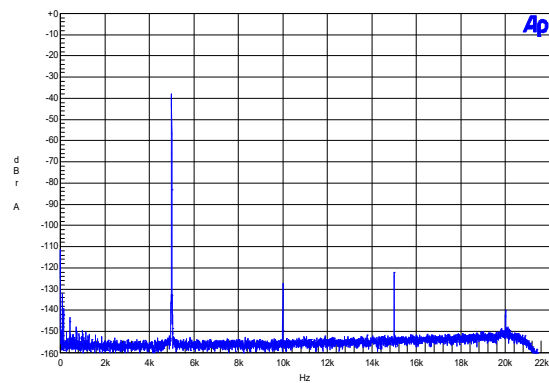
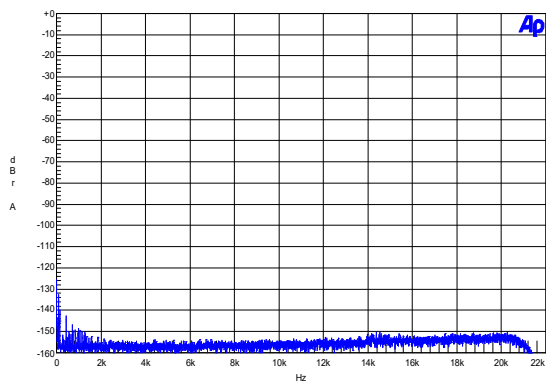

Idle noise (16K FFT). Residual = 35μV(A).
(Relative to 400W into 4 ohm)

f = 5kHz. Po = 100mW. 4Ω loading.
(Relative to 400W into 4 ohm)

Figure 6: Total harmonic distortion & noise (BTL).

8) An Audio Precision AES17 20 kHz 7th order measurement filter is used for measurements. The frequency 6.67 kHz corresponds to the worst-case scenario where both 2nd and 3rd harmonics are within the audio band.

Version 1.9

Intermodulation Distortion (CCIF & TIM) (SE-mode)

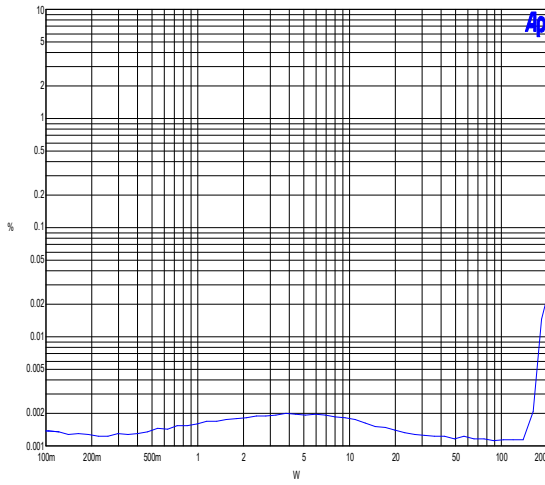

CCIF IMD vs. P_o , $R_L = 4\Omega$, $f_1 = 18,5\text{kHz}$, $f_2 = 1\text{kHz}$,
IMD@10W = 0.002%.

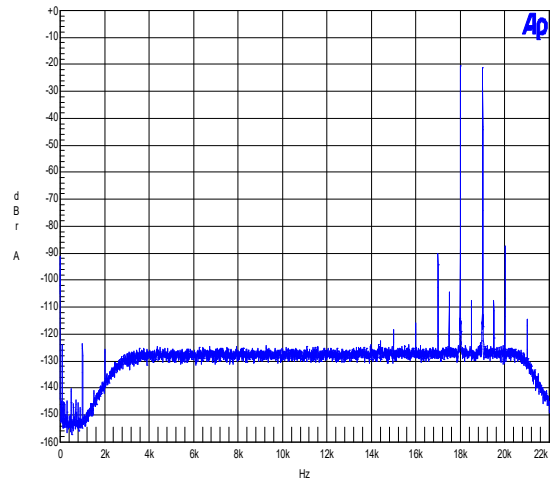

CCIF IMD analysis. $R_L = 4\Omega$, $P_o = 10\text{W}$.

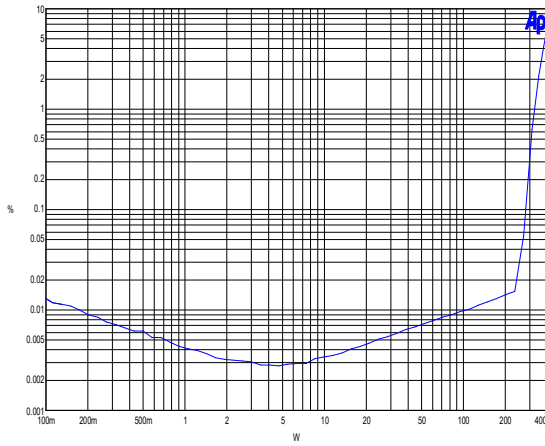

TIM vs. output power. $R_L = 4\Omega$,
TIM@10W = 0.004%

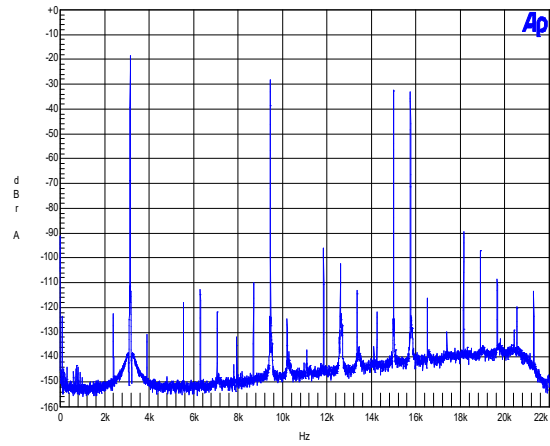

TIM FFT analysis. $R_L = 4\Omega$, $P_o = 10\text{W}$.

Figure 7: Intermodulation distortion (SE)

Version 1.9

Intermodulation Distortion (CCIF & TIM) (BTL-mode)

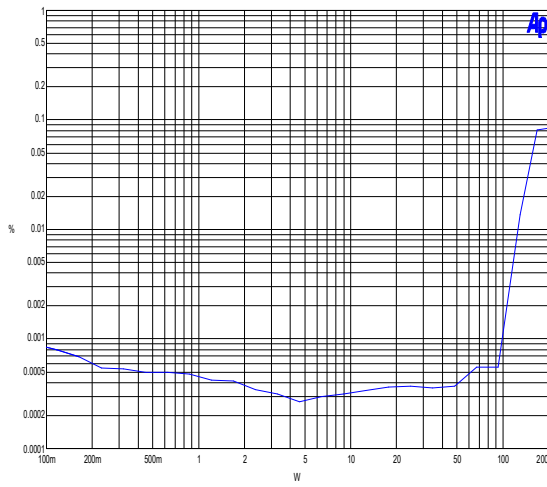

CCIF IMD vs. P_o , $R_L = 4\Omega$, $f_1 = 18.5\text{kHz}$, $f_2 = 1\text{kHz}$,
 $\text{IMD}@10\text{W} = 0.0003\%$.

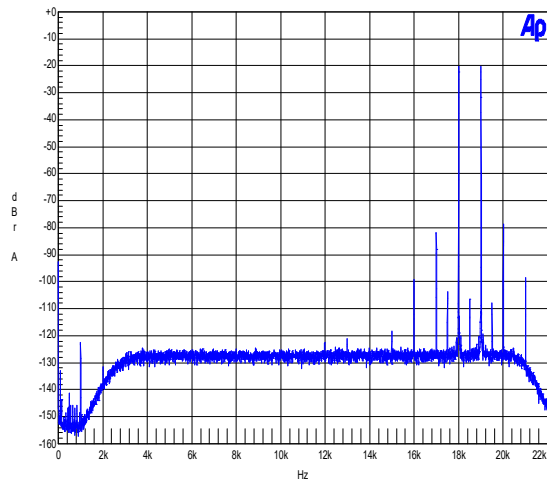

CCIF IMD analysis. $R_L = 4\Omega$, $P_o = 10\text{W}$.

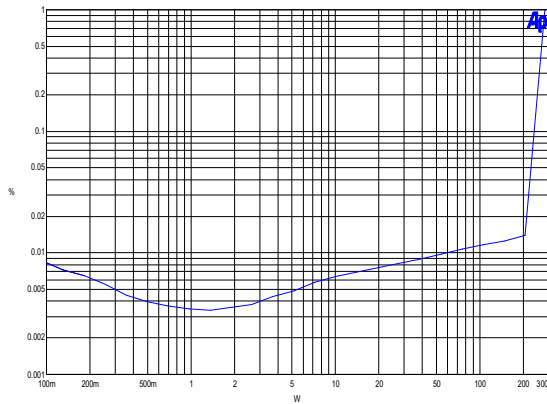

TIM vs. output power. $R_L = 4\Omega$,
 $\text{TIM}@10\text{W} = 0.006\%$

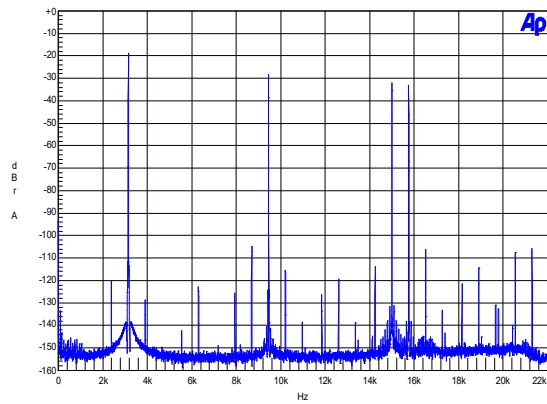

TIM FFT analysis. $R_L = 4\Omega$, $P_o = 10\text{W}$.

Figure 8: Intermodulation distortion (BTL).

Power vs. Frequency

The maximum allowable short-term output power of the ICEpower125SAX2 is frequency-dependant due to the compensating Zobel network in the output stage. The short-term output power is defined as the maximum undistorted (THD+N < 1%) output power until thermal shutdown occurs. The maximum Full Power Bandwidth is 20 kHz. Above this frequency, the Zobel protection circuit may briefly shut down the amplifier to protect the Zobel network from damage.

Note that this limitation will never cause problems when the amplifier is fed a music signal at the input, but the limit must be taken into consideration when the amplifier is tested under laboratory conditions using sine waves or noise signals.

Output Impedance

The output impedance is measured by feeding $1A_{RMS}$ into the output of the amplifier and measuring the voltage on the output. The voltage then corresponds to the output impedance. The output impedance is measured directly on the terminals on the PCB.

The figure below shows the output impedance from 100Hz – 20kHz BTL-mode (left) and for one channel in SE-mode (right).

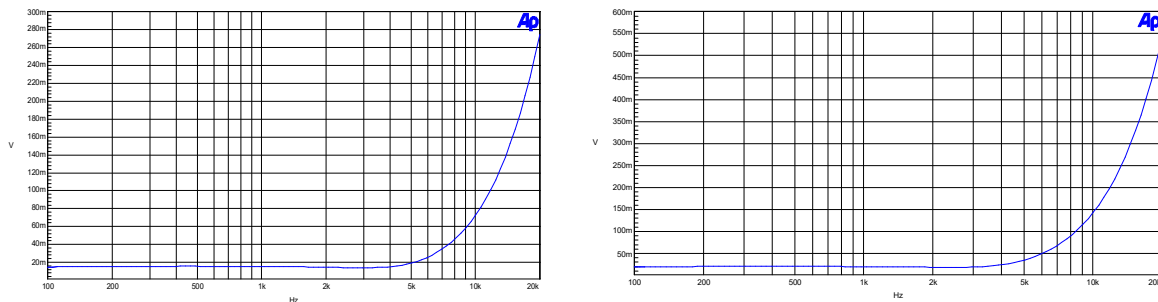

Figure 9: Measured voltage at output terminals while feeding $1A_{RMS}$ into the output of the amplifier at PCB.

Loading

With its low output impedance, the ICEpower125ASX2 is designed to be unaffected by loudspeaker loading characteristics. However, care should be taken with *purely* capacitive loads.

Traditionally amplifiers have been tested extensively in laboratories with purely capacitive loads. This was done to test the amplifier's stability and performance but it does not relate to any normal speaker load as even electrostatic speakers do not present a purely capacitive load to the amplifier but include a resistive part as well. The maximum purely capacitive load allowed is 390nF per channel in SE-mode or 220nF in BTL-mode.

Dissipated Power vs. Output Power

Mains Voltage [Vac]	Measured mains current draw [A]	Rated mains current draw [A]	Measured mains power draw [W]	Rated mains power draw [W]	Test Condition
90 Vac / 50 Hz	2.984	3	178.3	180	1 kHz sine wave input, all channels driven, (maximum) non-clipped output power, 4 ohm output loads in SE mode, +/-25V outputs loaded with 250 mA each.
132 Vac / 50 Hz	3.945	4	336.0	340	
180 Vac / 50 Hz	1.575	1.6	180.2	185	
264 Vac / 50 Hz	2.007	2.1	328.4	330	
90V / 60 Hz	2.922	3	178.0	180	
132 Vac / 60 Hz	3.85	3.9	338.3	340	
180 Vac / 60 Hz	1.574	1.6	180.2	185	
264 Vac / 60 Hz	1.954	2	328	330	
90 Vac / 50 Hz	4.74	4.8	300.1	305	1 kHz sine wave input, all channels driven, (maximum) non-clipped output power, 4 ohm output loads in BTL mode, +/-25V outputs loaded with 250 mA each.
132 Vac / 50 Hz	6.87	6.9	618	620	
180 Vac / 50 Hz	2.633	2.7	318	320	
264 Vac / 50 Hz	3.667	3.7	636	640	
90V / 60 Hz	4.77	4.8	300.2	305	
132 Vac / 60 Hz	6.70	6.75	616	620	
180 Vac / 60 Hz	2.579	2.6	316	320	
264 Vac / 60 Hz	3.568	3.6	637	640	
90 Vac / 50 Hz	0.686	0.7	36.8	38	1 kHz sine wave input, all channels driven, 1/8 non-clipped output power, 4 ohm output loads in SE mode, +/-25V outputs loaded with 250 mA each.
100Vac / 50 Hz	0.731	0.75	42.8	44	
120 Vac / 50 Hz	0.852	0.9	58.9	60	
132 Vac / 50 Hz	0.858	0.9	64.1	65	
180 Vac / 50 Hz	0.373	0.4	37.2	38	
200 Vac / 50 Hz	0.387	0.4	42.5	44	
240 Vac / 50 Hz	0.448	0.5	58.4	60	
264 Vac / 50 Hz	0.461	0.5	64.9	65	
90 Vac / 50 Hz	0.861	0.9	47.6	48	1 kHz sine wave input, all channels driven, 1/8 non-clipped output power, 4 ohm output loads in BTL mode, +/-25V outputs loaded with 250 mA each.
100Vac / 50 Hz	0.977	1	58.67	60	
120 Vac / 50 Hz	1.131	1.2	79.3	80	
132 Vac / 50 Hz	1.232	1.25	97.05	98	
180 Vac / 50 Hz	0.486	0.5	50.1	52	
200 Vac / 50 Hz	0.611	0.65	69.47	70	
240 Vac / 50 Hz	0.657	0.7	88.7	90	
264 Vac / 50 Hz	0.682	0.7	101.0	102	

Table 18: Dissipated power vs. Output power.

Features

The ICEpower125ASX2 has a number of useful features described below.

Over Current monitor pin

Figure 10 shows the internal circuit of the OC pin interface. This pin is high (+5V) during normal operation but it is pulled low (0V) if a short circuit is detected on the speaker output terminals.

This pin is also activated by other protection features such as Zobel protection and saturation detection on the output. If any of these protection features are activated, the pin will be pulled low (0V). This pin is only an output.

Figure 10: Over Current monitor pin interface

Thermal monitor pin

Figure 11 shows the internal circuit of the thermal pin interface. This pin is high (+5V) under normal conditions. If the amplifier temperature becomes too high, the pin is pulled low (0V). This can happen if the continuous power drawn from the amplifier exceeds the limits listed on p. 6 and p. 7. This pin is only an output.

Figure 11: Thermal monitor pin interface.

Enable pin

The enable pin can enable/disable the amplifier. If the pin is left unconnected, then the level is high (+5V) and the amplifier is enabled. If the pin is pulled low (0V) externally, the amplifier will be disabled.

The enable pin will also be pulled low by the internal protection circuitry if the amplifier temperature becomes too high or a mains under-voltage is detected. This pin is bidirectional.

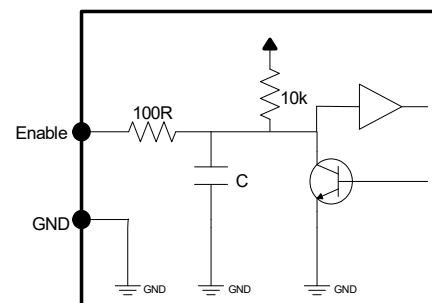

Figure 12: Enable pin interface.

BTL Sync pin

The BTL synchronization pin is used when the amplifier is operated in BTL mode. When the amplifier is used in BTL mode, the BTL sync pin must be pulled low (0V). By setting the BTL sync pin low, it is ensured that the switching frequencies of the two separate amplifier channels are tied closely together for optimized THD performance.

Figure 13: BTL sync pin interface

Auxiliary power supply

The auxiliary supply can be used to power an external circuit such as a preamplifier or an equalizer/crossover. Remember that this supply is unregulated.

When using this AUX supply, please remember to read the sections “Shielding and Grounding of Audio Signals” and “Capacitive Loading of the Aux Supply” in the ICEpower125ASX2 designer’s manual.

NOTE:

The Vd and Vs outputs are fused. Even brief overloads or short circuits will blow the fuse!

The fuse on the module is a 630mA type to keep the inrush-current from blowing the fuse, but the maximum current draw (sum of current from Vd,aux and Vc,aux) should never exceed 500mA.

Figure 14: Auxiliary supply equivalent diagram.

Protection Features

The ICEpower125ASX2 is equipped with several protection features for surviving overload without damage. The block diagram below illustrates the different protection features.

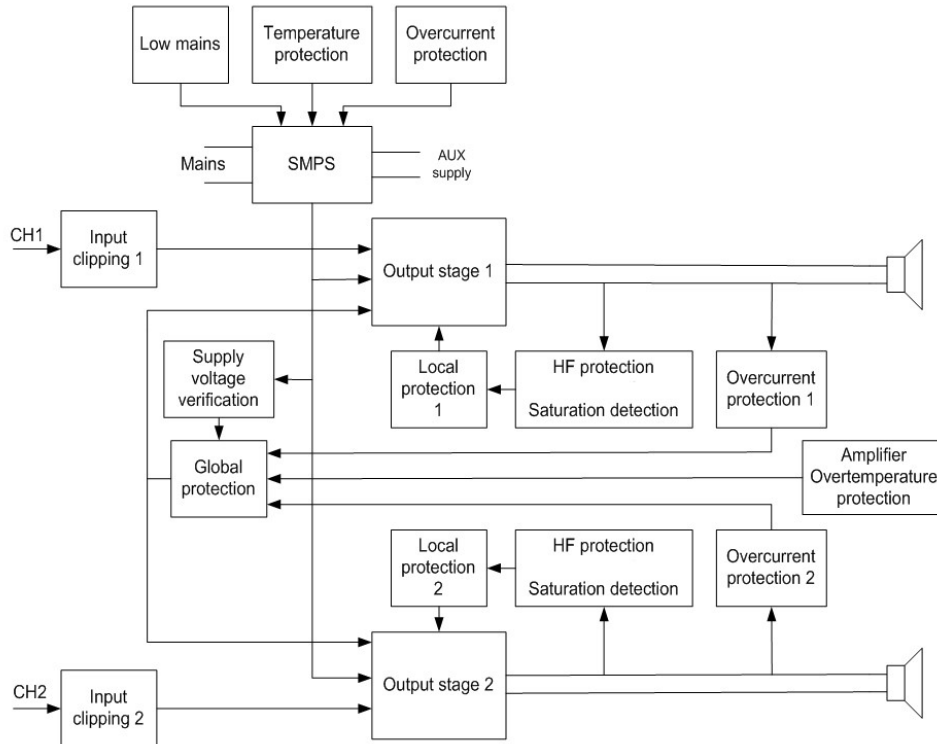

Figure 15: Protection schematic

Power Supply Protection

The power supply of the ICEpower125ASX2 has two protection circuits; over temperature and overcurrent.

The temperature protection will be activated if the absolute temperature of the circuit is too high. This can be caused by high ambient temperature, high load (amplifier and AUX supply) for a long time or a combination of these two parameters.

The overcurrent protection will be activated if the output current to amplifier and/or AUX exceeds the limits. Please remember that the AUX supply is protected by a fuse which will blow if the supply is overloaded.

If one of these protection features is triggered, the power supply either limits its output power or shuts down. In case of a shutdown, the power supply will rapidly try to restart if the circuit's temperature is acceptable.

Amplifier Local Protection

The ICEpower125ASX2 has a local protection circuit for each of the two audio channels. This local protection handles HF protection and saturation detection. If one of these protection features is activated on one channel, it will only influence the channel where the error occurred.

The HF protection circuit is implemented to protect the Zobel network against ultrasonic signals (greater than 20kHz). This protection circuit has a built-in time constant, so it is possible to deliver a high frequency, high amplitude signal for a short time.

Amplifier Global Protection

There are two global protection features in the ICEpower125ASX2 amplifier; an over temperature protection and an overcurrent protection.

The over temperature protection will only occur if the P_{RMS} is greater than the specified Continuous Output Power. In normal use, the amplifier will not shut down if properly mounted.

The overcurrent detection circuit is included in the ICEpower chipset by detecting saturation of the control system. This condition will typically be allowed for 100ms to 500ms which is enough to avoid accidental shutdown at peak currents during high music output. The current limit is set to 30A.

Input/Output Interface

Input Stage

The single ended input buffer has an anti-aliasing filtering and a DC blocking capacitor. The input impedance of the signal input section is minimum $8k\Omega$ over the audio bandwidth, which is an acceptable loading condition for pre-amps, active crossover outputs etc.

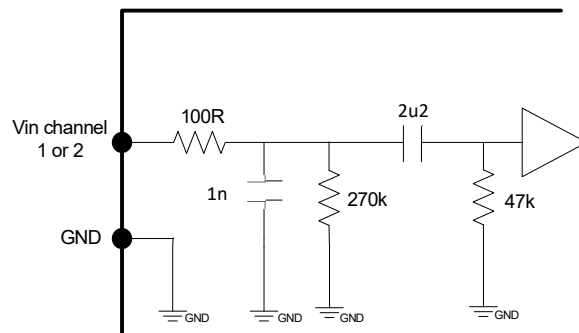

Figure 16: Single ended input buffer.

BTL module setup

When using the BTL module, the wiring diagram on fig. 17 should be followed. For optimized THD performance, the BTL sync pin is pulled low.

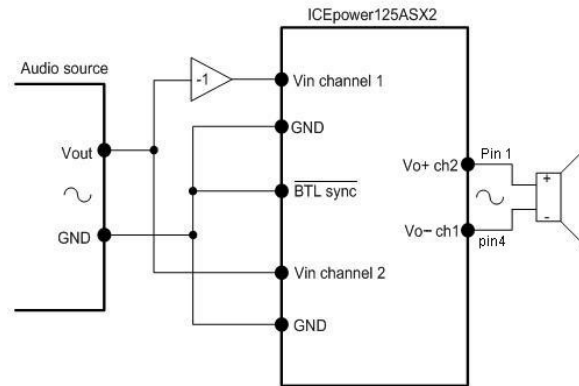

Figure 17: Wiring diagram for the BTL module

Output stage

The output stage is a half bridge topology with a 2nd order filter. The filter design is a part of ICEpower's proprietary MECC topology and has been chosen as the optimal solution between demodulation characteristics, efficiency and filter compactness. The essential output characteristics are:

- The switching residual on the output primarily consists of a single frequency component at the carrier fundamental f_s .
- The system bandwidth is 120 kHz in 8Ω (SE) and 100 kHz in 8Ω (BTL).

Figure 18: SE output filter section with compensating Zobel network.

Operational Timing Diagram

The following diagram shows selected signals during power up/down (nominal mains).

Timing for changes in mains and enable levels

1. 570ms
2. 30ms
3. 200us
4. 30ms
5. Up to 2 seconds (P_{out} dependent)
6. 30ms

Overcurrent and thermal pins have the same response delays as the enable pin from when the over current or thermal error is detected.

Figure 19: Timing – enable and mains.

Thermal Design

Thermal design is generally a great challenge in power amplifier systems. Linear amplifier designs operating in class A or AB are normally very inefficient and therefore equipped with extensive heat sinking to keep the transistor junction temperature low. The ICEpower125ASX2 is based on highly efficient ICE-power switching technology providing high overall efficiency characteristics at all levels of operation.

Part of the “component” philosophy of the ICEpower125ASX2 module is to provide a self-cooled component thus eliminating the need for special attention to thermal design.

The ICEpower125ASX2 module is designed for music reproduction, which means that the output power of the amplifier will never be continuous. Research has shown that the RMS level of any music signal does not normally exceed 1/8th of the peak value and the power supply is therefore designed for large short-term power handling and lower continuous power handling. If the average output power of the ICEpower125ASX2 exceeds 65W @ 4Ω (SE-mode with both channels driven) or 70W @ 4Ω (BTL-mode) for a long time at 25°C ambient temperature, the module will reach its maximum allowable temperature and the temperature protection will be activated.

Further information about thermal design can be found in the ICEpower ASX designer’s manual.

Physical Dimensions

All dimensions are in mm.

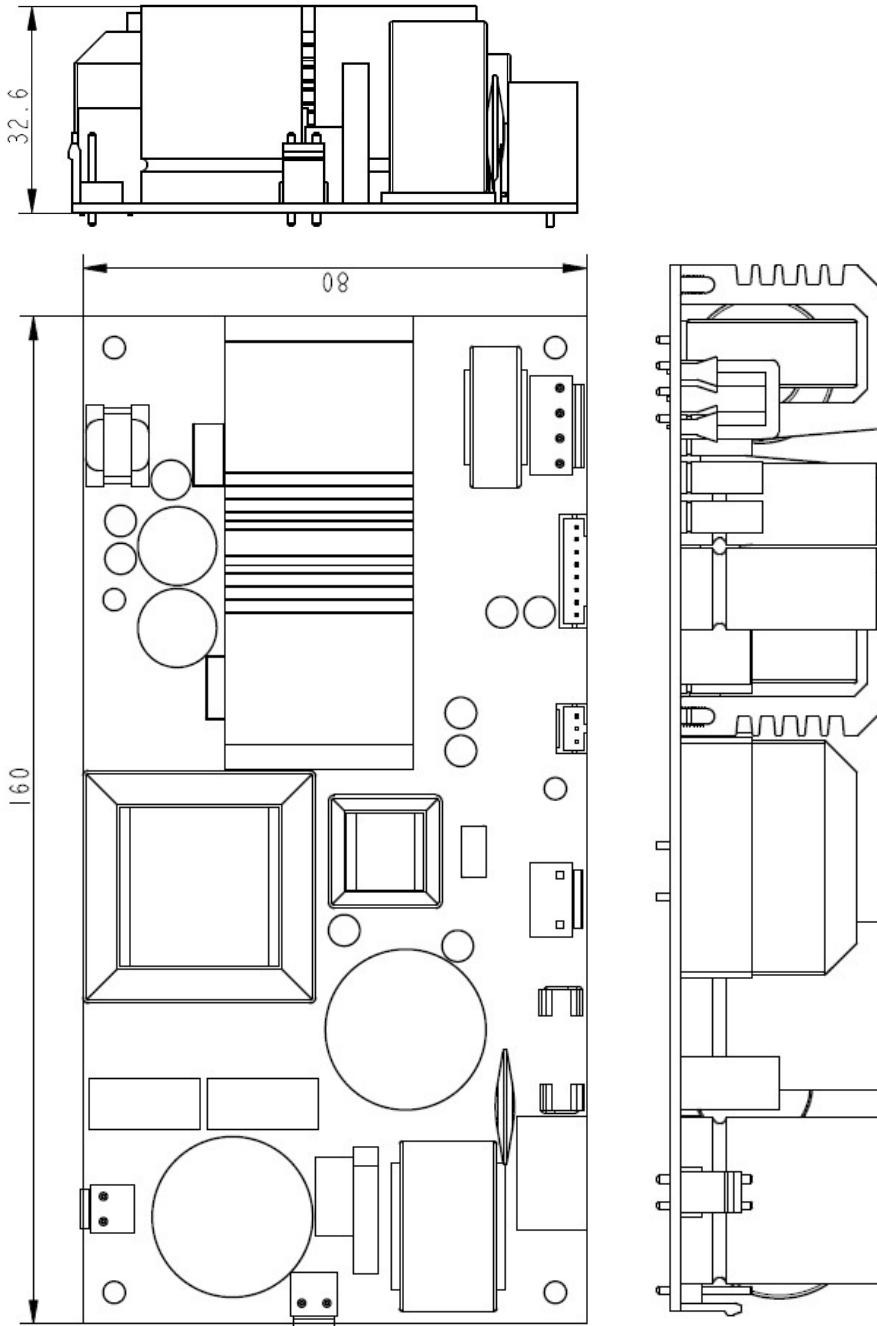

Figure 20: Physical dimensions in mm.

Important! A minimum clearance of 12 mm. around the module is required for safety and ventilation reasons.

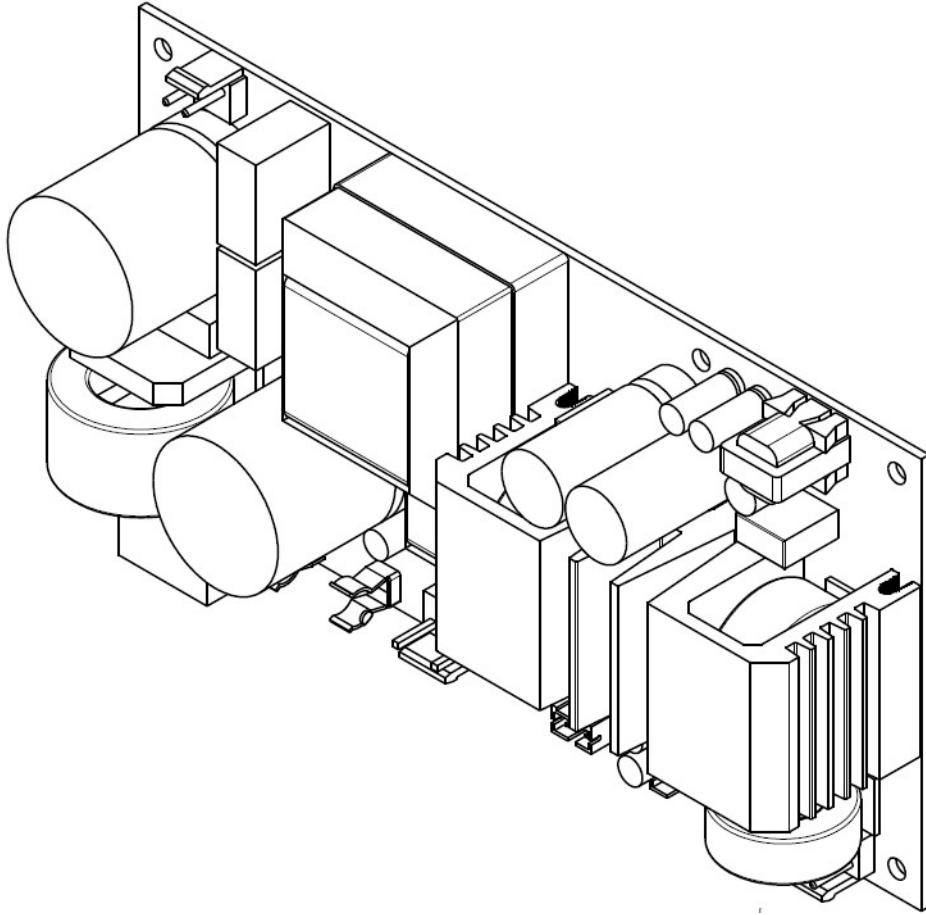

Figure 21: 3D-view of the ICEpower125ASX2 board.

DATASHEET
ICEpower125ASX2

Version 1.8

Drill Pattern

All dimensions are in mm. The diameter of the mounting holes is 3.5 mm and max. height above the PCB is 31 mm.

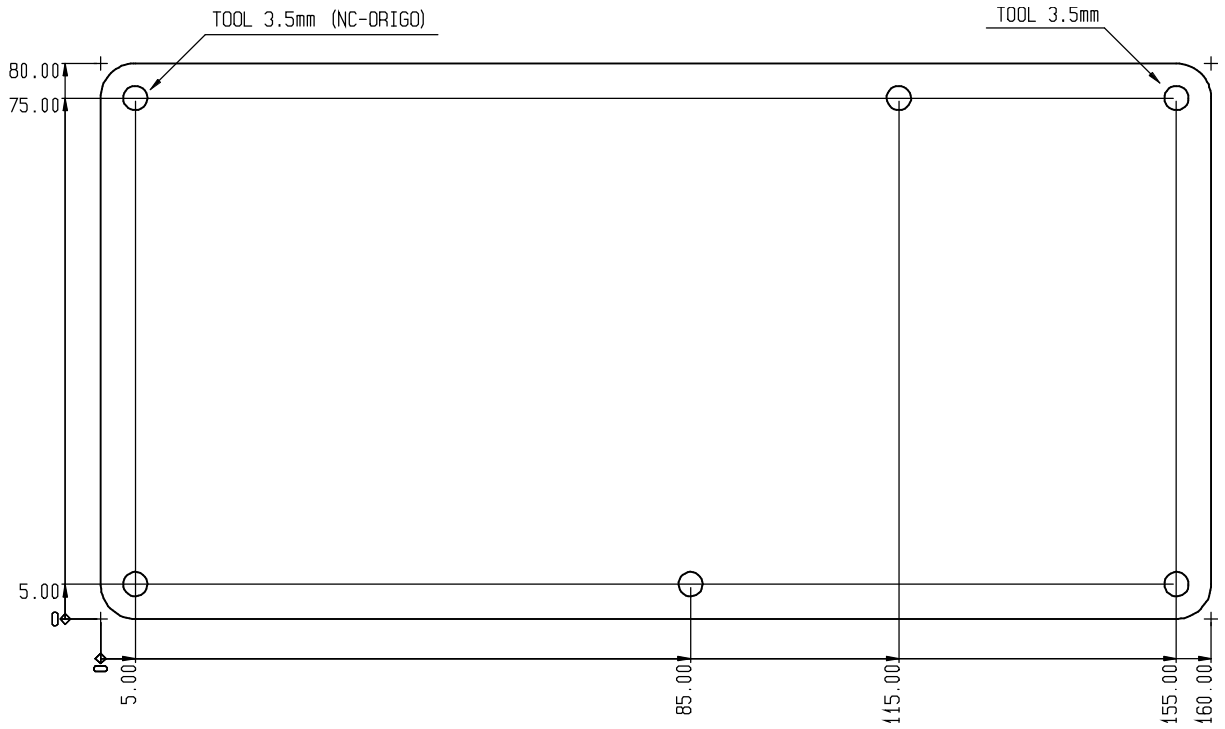

Figure 22: PCB drill pattern.

Safety Standards

The ICEpower125ASX2 is safety approved by CSA to ease the design-in procedure. The module complies with the following standards:

Europe:	IEC 62368: 2014 (second edition) IEC 60065 7th ed. + AM1 + AM2 IEC 60065 8th ed. EN 60065:2002 + A1:2006 + A11:2008 + A2:2010
US:	UL 62368-1 and CAN/CSA C22.2 No. 62368-1-14 UL 60065, 7th Edition, 2013-07-24 CAN/CSA-C22.2 No. 60065-03, 1st Edition + A1:2006 + A2:2012

EMC

- EN 55032: Note 1

Note1: Depends on cable routing on the mains/amplifier outputs and load characteristics. Connecting safety ground to the mains side/ Additional filtering may be needed.

Safety Class

Class 2 (without earth)

ESD Warning

ICEpower products are manufactured according to the following ESD precautions:

- IEC 61340-5-1: Protection of electronic devices from electrostatic phenomena. General Requirements.
- IEC 61340-5-2: Protection of electronic devices from electrostatic phenomena. User Guide.
- ANSI/ESD-S20.20-1999: Protection of Electrical and Electronic Parts, Assemblies and Equipment.

Further handling of the products should comply with the same standards.

The general warranty policy of ICEpower a/s does not cover ESD damaged products due to improper handling.

Packaging and Storing

Dimensions and weight

Package	Quantity	Dimensions (w x d x h) [mm]	Gross Weight [kg]
Carton	36	400 x 580 x 220	16.5 (kg)
Pallet	864	800 x 1200 x 1410	420 (kg)

ESD safe cardboard is used for wrapping.

Order Codes	Description	Part Number
ICEpower125ASX2	2x125W or 1x500W ICEpower Amplifier with integrated ICEpower Supply	8002661

Storage humidity

Do not expose the pallets to humidity levels higher than 85% or rain.

Storage temperature

The pallets are to be stored at temperatures from 0°C to 70°C.

Stacking

Pallets may not be stacked on top of each other.

Contact

For additional information about the ICEpower® technology from ICEpower a/s, visit our web site or contact us.

ICEpower a/s
Vandtårnsvej 62A. 3rd floor B
DK-2860 Søborg
Denmark

www.icepower.dk
info@icepower.dk

Legal Notes

ICEpower a/s believes that the information in this datasheet is accurate and reliable. However it is provided "as is" without any warranties of any kind. ICEpower a/s and its suppliers, to the fullest extent permitted by law, disclaim all warranties, including the warranty of merchantability, warranty of non-infringement of third-party rights, and the warranty of fitness for a particular purpose. ICEpower a/s and its suppliers make no warranties about the accuracy, reliability, completeness, or timeliness of the material, services, software, text, graphics and links. In no event will ICEpower a/s be liable to any party for any damages whether direct, indirect, special, consequential or other for any use or inability to use of this datasheet, including, without limitation, any damages for lost profits, business interruption, loss of programs or other data on your information handling system or otherwise, even if we are expressly advised of the possibility of such damages.

Information in this datasheet may contain technical inaccuracies or typographical errors. The information in the datasheet may be changed at any time without prior notice or obligation.

ICEpower® is a trademark of ICEpower a/s.

ICEpower a/s products are not authorized for use as critical components in life support devices or life support systems without the express written approval of the president and general counsel of ICEpower a/s. As used herein:

- Life support devices or systems are devices or systems which, (a) are intended for surgical implant into the body, or (b) support or sustain life, and whose failure to perform when properly used in accordance with instructions for use provided in the labelling, can be reasonably expected to result in a significant injury to the user.
- A critical component is any component of a life support device or system whose failure to perform can be reasonably expected to cause the failure of the life support device or system, or to affect its safety or effectiveness.