



Spider II HD75

Service Manual

6

5

4

3

2

1

ECOs INCLUDED ON THIS SCHEMATIC/PCB REVISION		
ECO NO:	DATE:	DESCRIPTION:
0505302	2.23.05	Released as rev.A to MFG - mh
0510103	4.11.05	Changed R65 & R66 to 1K 1W

D

D

C

C

B

B

A

A

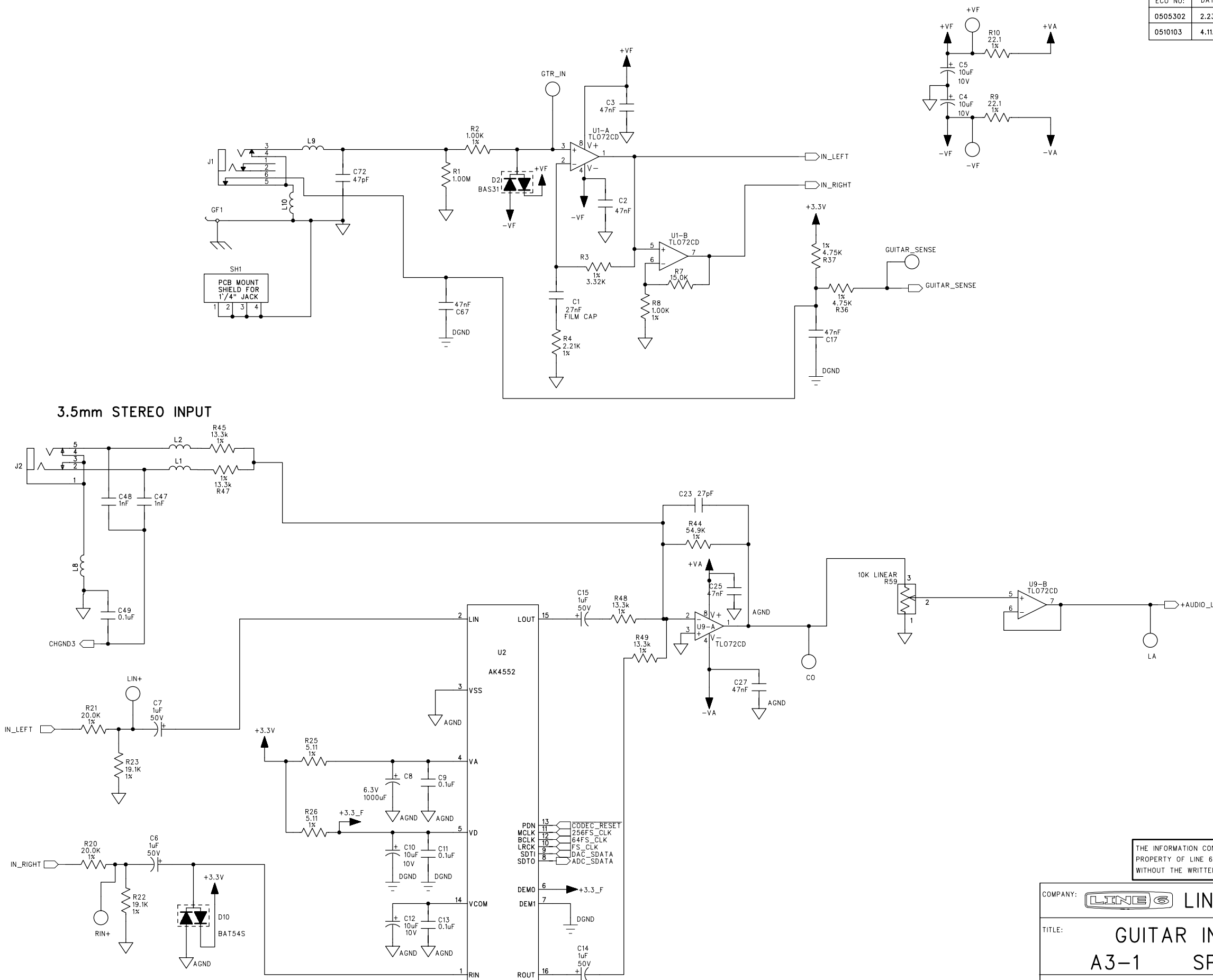

3.5mm STEREO INPUT

THE INFORMATION CONTAINED IN THIS DRAWING IS THE SOLE PROPERTY OF LINE 6 INC. ANY REPRODUCTION IN PART OR WHOLE WITHOUT THE WRITTEN PERMISSION OF LINE 6 INC. IS PROHIBITED

COMPANY: LINE 6	
TITLE: GUITAR IN / CODEC A3-1 SPIDER2 HD75	
PROGRAM: PADS POWER LOGIC V5.0	REV: A1
FILENAME: A3-1_MAIN_LED_REV_A1.sch	
SCALE: 1:1	SIZE: C
PART NUMBER: 35-00-0059	SHEET: 1 OF 4

DRAWN: T. BURTON	DATED: 2/15/05
CHECKED:	DATED:

DIGITAL SECTION

ECOs INCLUDED ON THIS SCHEMATIC/PCB REVISION		
ECO NO:	DATE:	DESCRIPTION:

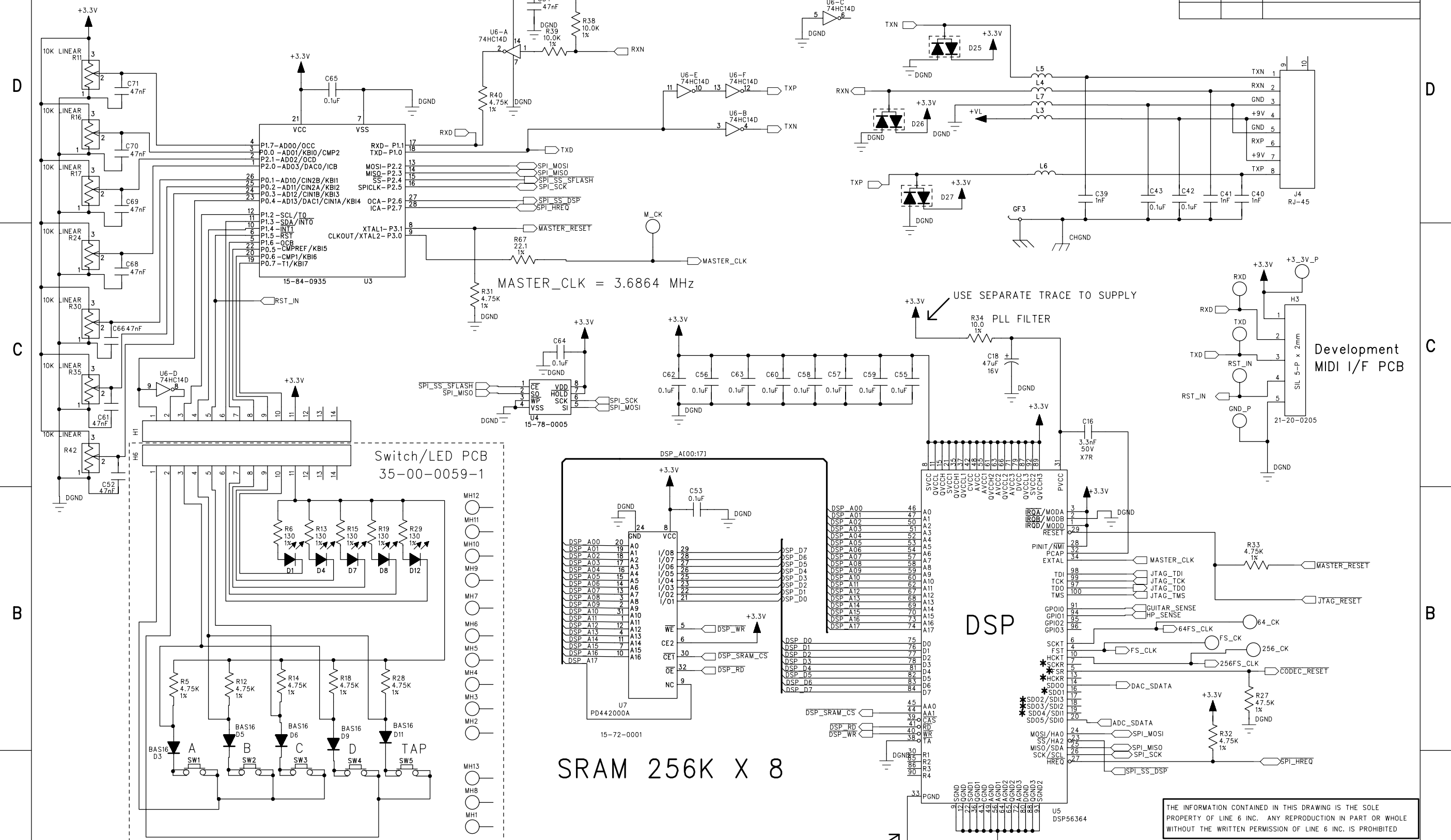

DSP CORE CLOCK = 99,993,600 Hz (approx 100MHz)
 256FS_CLK = 9,999,360 Hz
 64FS_CLK = 2,499,840 Hz
 FS_CLK = 39,060 Hz



USE SEPARATE TRACE TO SUPPLY
 * = DO NOT INSTALL

THE INFORMATION CONTAINED IN THIS DRAWING IS THE SOLE PROPERTY OF LINE 6 INC. ANY REPRODUCTION IN PART OR WHOLE WITHOUT THE WRITTEN PERMISSION OF LINE 6 INC. IS PROHIBITED

COMPANY:	LINE 6
TITLE:	DIGITAL SECTION A3-1 SPIDER2 HD75
PROGRAM:	PADS POWER LOGIC V5.0
FILENAME:	A3-1_MAIN_LED_REV_A1.sch
SCALE: 1:1	SIZE: C
PART NUMBER: 35-00-0059	SHEET: 2 OF 4

DRAWN:	T. BURTON	DATED:	2/15/05
CHECKED:		DATED:	

REV: **A1**

6

5

4

3

2

1

POWER AMP / HEADPHONE AMP

ECOs INCLUDED ON THIS SCHEMATIC/PCB REVISION		
ECO NO:	DATE:	DESCRIPTION:

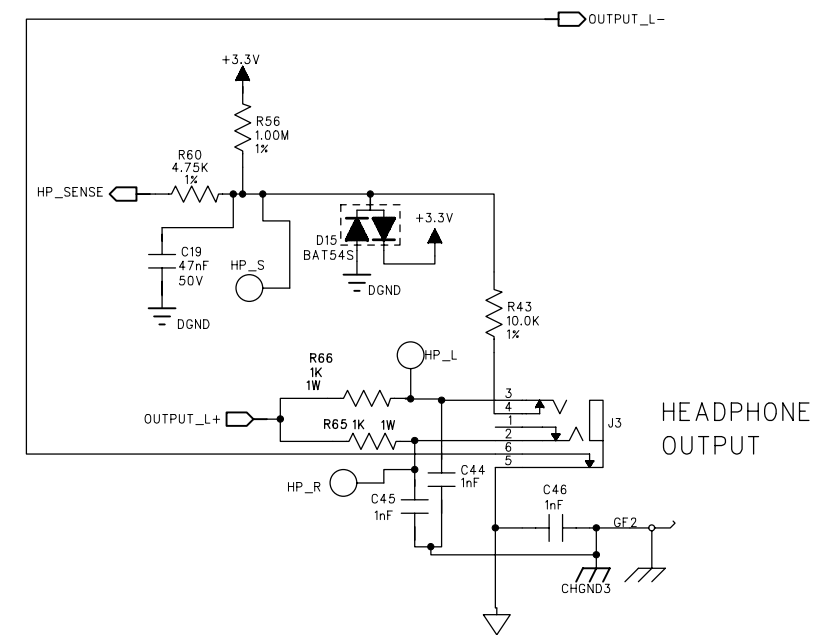
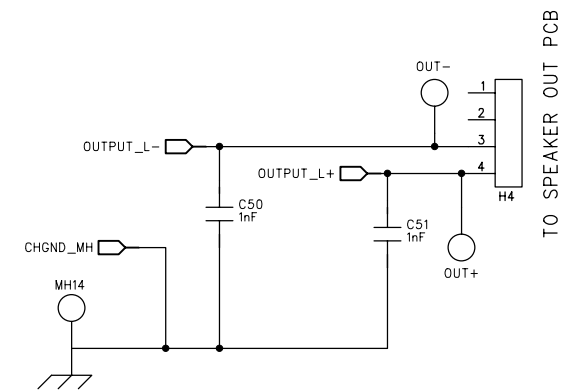
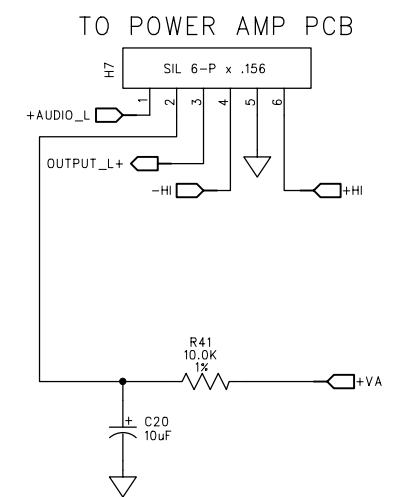

THE INFORMATION CONTAINED IN THIS DRAWING IS THE SOLE PROPERTY OF LINE 6 INC. ANY REPRODUCTION IN PART OR WHOLE WITHOUT THE WRITTEN PERMISSION OF LINE 6 INC. IS PROHIBITED

COMPANY: **LINE 6**

TITLE: **A3-1 SPIDER2 HD75 POWER AMP / HEADPHONE AMP**

PROGRAM: PADS POWER LOGIC V5.0

FILENAME: A3-1_MAIN_LED_REV_A1.sch

SCALE: 1:1 SIZE: C PART NUMBER: 35-00-0059 SHEET: 3 OF 4

DRAWN: T. BURTON

DATED: 2/15/05

CHECKED:

DATED: Date

REV: **A1**

6

5

4

3

2

1

POWER SUPPLY

ECOs INCLUDED ON THIS SCHEMATIC/PCB REVISION		
ECO NO:	DATE:	DESCRIPTION:

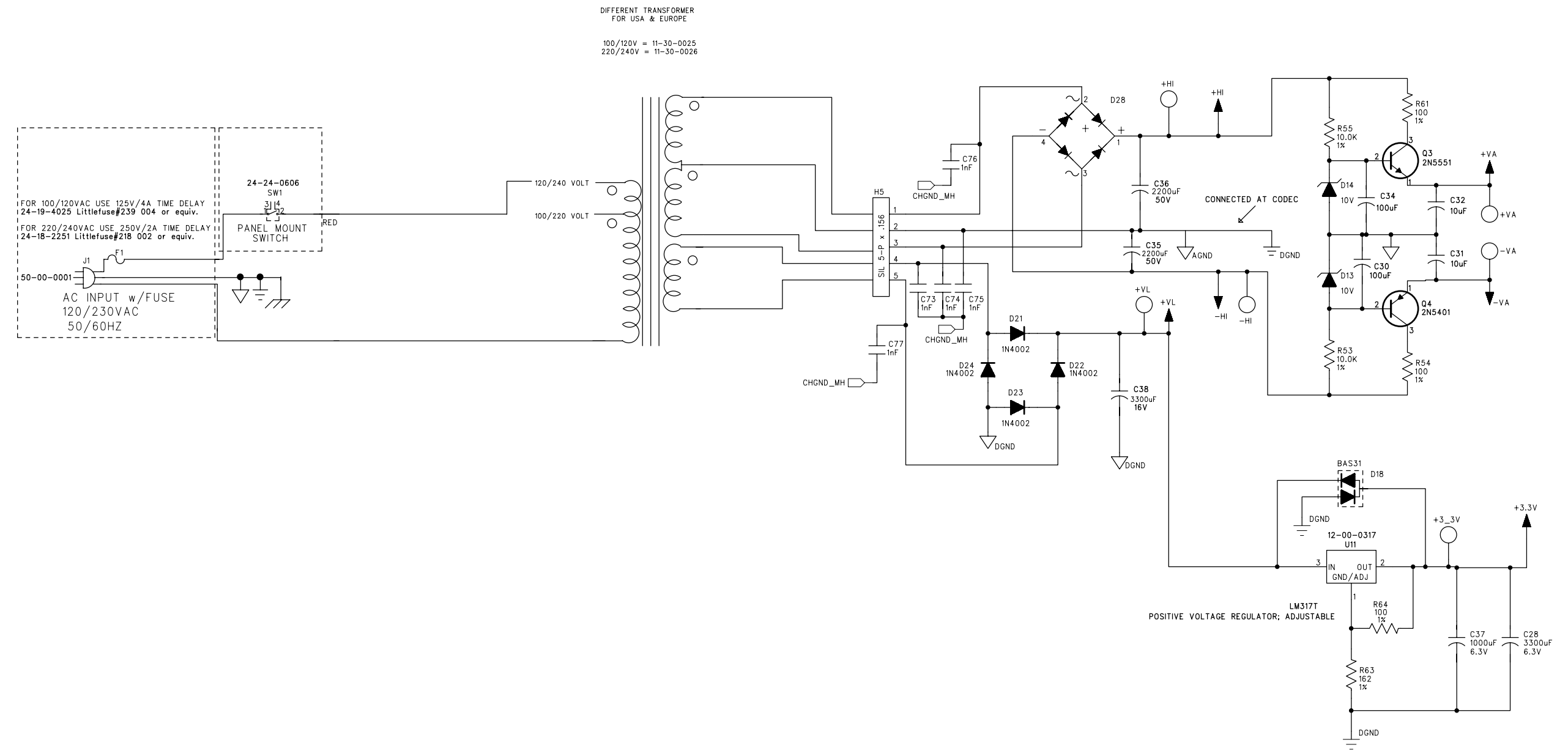

FOR 100/120VAC USE 125V/4A TIME DELAY
24-19-4025 Littlefuse#239 004 or equiv.

FOR 220/240VAC USE 250V/2A TIME DELAY
24-18-2251 Littlefuse#218 002 or equiv.

AC INPUT w/FUSE
120/230VAC
50/60HZ

24-24-0606
SW1
PANEL MOUNT
SWITCH

DIFFERENT TRANSFORMER
FOR USA & EUROPE

100/120V = 11-30-0025
220/240V = 11-30-0026

POSITIVE VOLTAGE REGULATOR; ADJUSTABLE

LM317T

BAS31

12-00-0317
U11

THE INFORMATION CONTAINED IN THIS DRAWING IS THE SOLE
PROPERTY OF LINE 6 INC. ANY REPRODUCTION IN PART OR WHOLE
WITHOUT THE WRITTEN PERMISSION OF LINE 6 INC. IS PROHIBITED

COMPANY:	LINE 6
TITLE:	A3-1 SPIDER2 HD75 POWER SUPPLY
PROGRAM:	PADS POWER LOGIC V5.0
REV:	A1
FILENAME:	A3-1_MAIN_LED_REV_A1.sch
SCALE: 1:1	SIZE: C
PART NUMBER: 35-00-0059	SHEET: 4 OF 4

DRAWN:	T. BURTON	DATED:	2/15/05
CHECKED:		DATED:	

6

5

4

3

2

1

POWER AMP

ECOs INCLUDED ON THIS SCHEMATIC/PCB REVISION		
ECO NO:	DATE:	DESCRIPTION:
0505302	02.23.05	Released as rev.A to MFG - (mh)

NOTE: THIS PCB HAS BOTH THE POWER AMP AND SPEAKER OUT DESIGNS

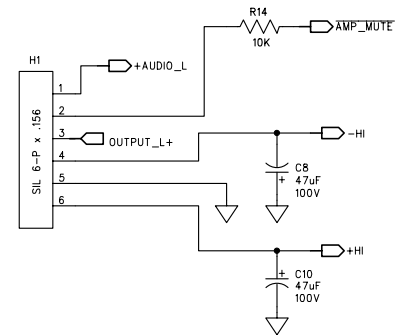

BR1
PCB SUPPORT CLIP
30-51-0105

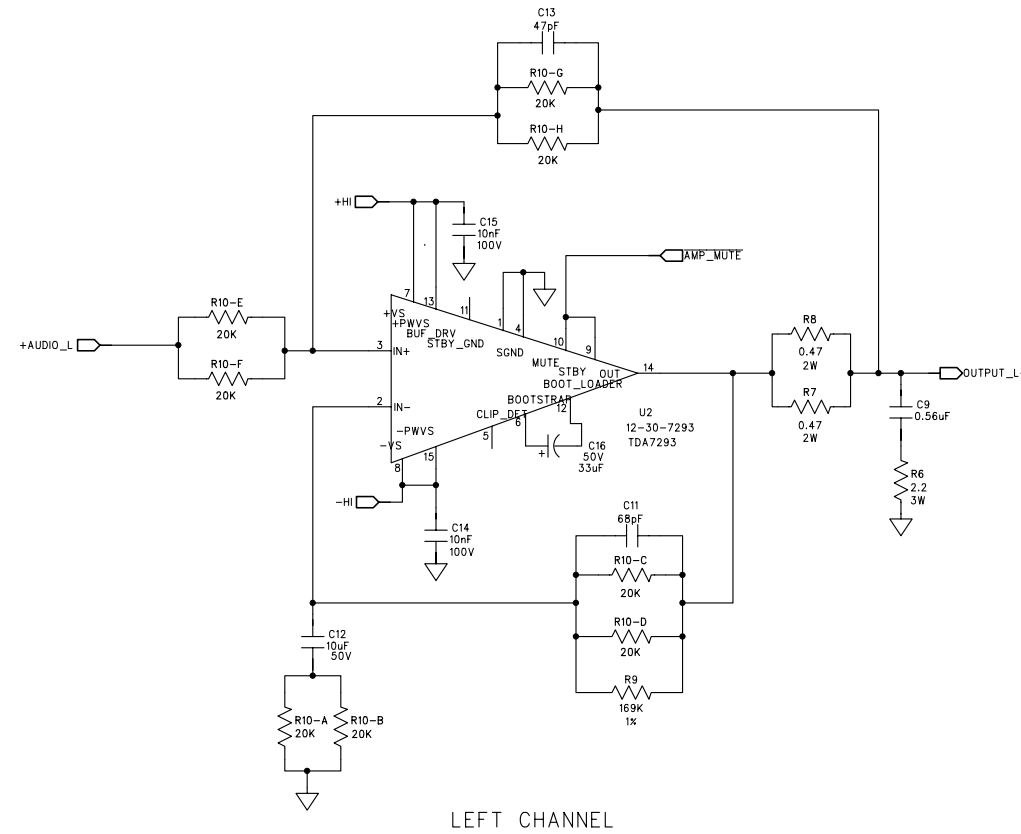

LEFT CHANNEL

THE INFORMATION CONTAINED IN THIS DRAWING IS THE SOLE PROPERTY OF LINE 6 INC. ANY REPRODUCTION IN PART OR WHOLE WITHOUT THE WRITTEN PERMISSION OF LINE 6 INC. IS PROHIBITED

COMPANY: **LINE 6**

TITLE: **A3-1 SPIDER II HD75
POWER AMP / SPEAKER OUT**

PROGRAM: **PADS POWER LOGIC V5.0**

DRAWN:
T. BURTON
CHECKED:

DATED:
2/15/05
DATED:
Date

FILENAME:
SCALE: 1:1 SIZE: C PART NUMBER: 35-00-0061 SHEET: 1 OF 2

REV:
A

6

5

4

3

2

1

SPEAKER OUT

NOTE: THIS PCB HAS BOTH THE AMP AND SPEAKER OUT DESIGNS

ECOs INCLUDED ON THIS SCHEMATIC/PCB REVISION		
ECO NO:	DATE:	DESCRIPTION:

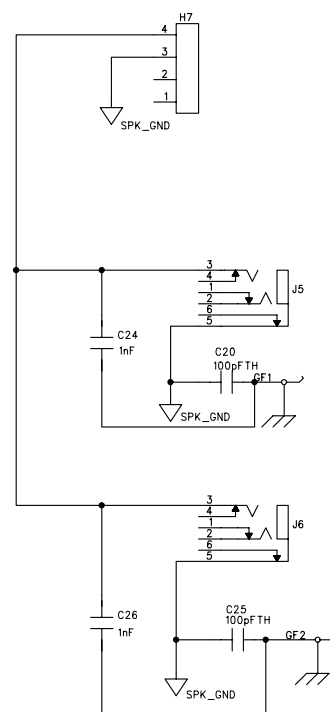

THE INFORMATION CONTAINED IN THIS DRAWING IS THE SOLE PROPERTY OF LINE 6 INC. ANY REPRODUCTION IN PART OR WHOLE WITHOUT THE WRITTEN PERMISSION OF LINE 6 INC. IS PROHIBITED

COMPANY: LINE 6	
TITLE: A3-1 SPIDER II HD75 POWER AMP / SPEAKER OUT	
PROGRAM: PADS POWER LOGIC V5.0	REV: A
DRAWN: T. BURTON	DATED: 2/15/05
CHECKED:	DATED:
SCALE: 1:1	SIZE: C
PART NUMBER: 35-00-0062	SHEET: 2 OF 2

D

D

C

C

B

B

A

A

99-020-0915 Spider II HD75 Packout

Part Number	Description	Qty. Per
40-00-0049	GUIDE POP-TOP SPIDER2-3012	1
40-00-0053	MANUAL USER UNIVERSAL SPIDER2-1508/3012/A3	1
59-00-0006-4	ASSY UNIT COMPLETE HEAD US SPIDER2-HD75 A3-1	1

59-00-0006-4 ASSY UNIT COMPLETE HEAD US SPIDER2-HD75

Part Number	Description	Qty. Per
30-00-1128	SCREW 10-32 x 1-3/4 OVAL CTSK PB STL	4
30-03-0112	WASHER FINISHING #10 FLANGED STL BLK OXIDE	4
40-25-0020	LABEL INSPECTION QUALITY	1
40-25-0062	STICKER SPEAKER-GRILL PROMO S1-1 SPIDER2-HD75	1
50-03-0004	ASSY CABINET SPIDER2-HD/A3-1	1
50-04-0024	ASSY E/M CHASSIS SPIDER2-HD75 A3-1 US	1

50-03-0004 ASSY CABINET SPIDER2-HD75

Part Number	Description	Qty. Per
30-00-0812	SCREW w/WAX 8 x 3/4 PTB	14
30-00-1024	SCREW 10-24 x 1IN OVAL CTSK PPB STL WAXED	2
30-00-6839	SCREW WOOD 10-12 x 7/8" PPZ	4
30-00-8112	SCREW WOOD #8 x 1 1/2" OVAL PHH STL BLK OXIDE	5
30-03-0112	WASHER FINISHING #10 FLANGED STL BLK OXIDE	5
30-06-1024	NUT-T 10-24 X 5/16 STEEL	2
30-28-0002	CORNER LEFT HI-DENSITY POLYETHYLENE TEXTURED BLACK	1
30-28-0003	CORNER RIGHT HI-DENSITY POLYETHYLENE TEXTURED BLACK	1
30-28-0004	CORNER BACK HI-DENSITY POLYETHYLENE TEXTURED BLACK	6
30-33-0029	CABINET PARTICLE BOARD 5/8IN 26.19x10.5x8.72-IN SPIDER2-HD	1
30-36-0005	COVER VINYL TEXTURED BLACK SEMI-GLOSS	0.75
30-39-0006	GRILL-CLOTH BLACK WEAVE	0.2
30-57-0580	HANDLE/STRAP HEAVY DUTY BLACK	1
30-57-0581	ENDCAPS BLACK TEXTURED FINISH	2
30-75-0008	FOOT RUBBER 1.50" I.D. x .75"HBLACK	4

50-04-0024 ASSY E/M CHASSIS SPIDER2-HD75

Part Number	Description	Qty Per
11-30-0025	XFMR 100/120VAC 50/60Hz 76mm 27.4VACx2 / 7.2VAC 3-CONN A3-1	1
21-37-0001-5	CBL POWER US/JA 10A/250V 8-FT 18AWG AC-PLUG to CRIMP-TERM x3	1
24-19-4025	FUSE 4A 125V TL 5x20mm Littlefuse# H239 004 or equiv.	1
24-24-0606	SWITCH POWER ROCKER 6A/250VAC 10A/120VAC PNL-MNT BLK	1
30-00-0018	SCREW SELF-TAP 6-32 x .75 PFZ	4
30-00-0375	SCREW 6-32 x .375 PPB	3
30-00-1033	SCREW 10-32 x 3/8IN SCH STL BLK OXIDE	12
30-06-0832	NUT .335 HEX 8-32 STL ZINC W/ TOOTH WASHER	4
30-27-0131	PANEL FRONT-EXT 4.0 x 2.0 ABS SPIDER2-HD75 A3-1	2
30-27-0156	PANEL U/I 16.69 x 3.83-IN ABS GREY SPIDER2-HD75 A3-1	1

30-45-0011	KNOB POT .77 DIA x .76 HT PLASTIC CHROME-PLATED	8
30-51-0202	CHASSIS 16.5 x 7.7 x 4.8 x.060THK STL SPIDER2-HD75 A3-1	1
30-63-0010	FOAM w/ADHSV 26.5x 1/4x 1/16INVOLARAPOLEFIN	6
30-75-0020	KEYPAD RUBBER 6.74 x .57 x0.23BLK SPIDER2-3012/1508/A3-1	1
30-75-0021	STRAIN RELIEF BUSHING 13.5MM x12MM	1
40-00-0043	CHART PRESET SHARCBOD SERIES	2
40-25-0018	STICKER LINE6 LOGO OVAL 109.5x28.5mm EPOXY CLEAR	1
50-02-0059	PCBA MAIN/SWITCH-LED SPIDER2-HD75 A3-1	1
50-02-0062	PCBA SPEAKER OUT SPIDER2-HD75 A3-1	1
50-02-0065	PCBA SWITCH/LED SPIDER2-HD75 A3-1	1
50-02-0066	PCBA POWER AMP w/HEATSINK SPIDER2-HD75 A3-1	1

50-02-0059 PCBA MAIN/SWITCH-LED SPIDER2-HD75

Part Number	Description	Qty Per
01-21-0102	RES METAL OXIDE 1K 1W 5% TH	2
01-24-1000	RES 100R 1% 0805	3
01-24-1001	RES 1.00K 1% 0805	2
01-24-1002	RES 10.0K 1% 0805	6
01-24-1004	RES 1.00M 1% 0805	2
01-24-10R0	RES 10.0R 1% 0805	1
01-24-1332	RES 13.3K 1% 0805	4
01-24-1502	RES 15.0K 1% 0805	1
01-24-1620	RES 162R 1% 0805	1
01-24-1912	RES 19.1K 1% 0805	2
01-24-2002	RES 20.0K 1% 0805	2
01-24-2211	RES 2.21K 1% 0805	1
01-24-22R1	RES 22.1R 1% 0805	3
01-24-3321	RES 3.32K 1% 0805	1
01-24-4751	RES 4.75K 1% 0805	7
01-24-4752	RES 47.5K 1% 0805	1
01-24-5492	RES 54.9K 1% 0805	1
01-24-5R11	RES 5.11R 1% 0805	2
01-48-0001	POT MONO CTR-DTNT10KB LINEAR 9mm/20mm SHFT 18-TH KNURLD HOR	8
03-10-0106	CAP ELEC 10uF 10V 20% RADIAL 5/11/5	4
03-10-0338	CAP ELEC 3300uF 6.3V 20% RADIAL 10/20/5	1
03-10-6108	CAP ELEC 1000uF 6.3V 20% RADIAL 8/11.5/5	2
03-12-0107	CAP ELEC 100uF 16V 20% RADIAL 6.3/11/5	2
03-12-0476	CAP ELEC 47uF 16V 20% RADIAL 6.3/11.2/5	1
03-12-1338	CAP ELEC 3300uF 16V 20% RADIAL12.5/25/5	1
03-18-0105	CAP ELEC 1uF 50V 20% RADIAL 5/11/5	4
03-18-0106	CAP ELEC 10uF 50V 20% RADIAL 5/11/5	3
03-18-0228	CAP ELEC 2200uF 50V 20% RADIAL 16/31.5/7.5	2
03-24-0273	CAP MET-POLY 27nF 50V 5% TH 7.3/3.2/5/5	1
03-50-0270	CAP NPO 27pF 50V 5% 0805	1
03-52-0103	CAP X7R 10nF 50V 10% 0805	15
03-52-0104	CAP X7R 0.1uF 50V 10% 0805	17
03-52-0332	CAP X7R 3.3nF 50V 10% 0805	1
03-52-0470	CAP X7R 47pF 50V 10% 0805	1
03-52-0473	CAP X7R 47nF 50V 10% 0805	14
06-04-4002	DIODE SMALL-SIGNAL 100V 30A DO-41 AXIAL TH 1N4002	4

06-16-0008	DIODE BRIDGE-RECT 8A 600V 4-PIN SIL TH KBU8J	1
06-23-0054	DIODE SCHOTTKY DUAL 30V 200mA 5nS SOT-23 SM BAT54S	2
06-28-8410	DIODE ZENER 10V 5% 350mW SOT-23 SM BZX84C10	2
06-34-0031	DIODE GEN PUR DUAL 120V 600mA 50nS SOT-23 SM BAS31	5
09-00-5401	TRANS PNP SMALL-SIGNAL 2N5401 TH	1
09-00-5551	TRANS NPN SMALL-SIGNAL 2N5551 TH	1
11-10-2012	FERRITE BEAD 600R@100MHZ 300mA 0805 SM	10
12-00-0317	IC VREG ADJ 1.2-37V 1.5 AMP TO-220 LM317 TH	1
12-54-0072	IC OP-AMP DUAL TL072CD SM	2
12-64-4552	IC CONVERTER 3V 24B 96KHz AUDIO CODEC SM AK4552	1
15-62-0014	IC 74HC14 INVERTER HEX SCHMITT TRIGGER SO-14 SM	1
15-72-0001	IC SRAM-256K x 8 TSOP32 SM	1
15-86-0364	IC DSP 24-BIT TQFP-100 SM XCB56364FU100	1
21-00-6616	JACK 1/4" TRS 6-PIN PCB MT HORIZ TH	2
21-12-0035	JACK 3.5mm STEREO 5 PIN CRIMPED LEADS NON-THREADED	1
21-16-0045	JACK RJ-45 8-PIN FEMALE PCB-MNT RT-ANG	1
21-20-0205	HDR SIL PCB-MT 5-PIN x 2mm MALE SHRD VERT MT TH	1
21-20-0206	HDR SIL PCB-MT 6-PIN x 2mm MALE SHRD VERT MT TH	1
21-20-1564	HDR SIL PCB-MT 4-PIN X .156 MALE VERT-MNT FRIC-LOCK	1
21-20-1565	HDR SIL PCB-MT 5-PIN X .156 MALE VERT-MNT FRIC-LOCK	1
21-20-1566	HDR SIL PCB-MT 6-PIN X .156 MALE VERT-MNT FRIC-LOCK	1
21-30-0029	CBL DIL 14 PIN .100 PITCH 2.0 IN RIBBON STAKED TO FEMALE	1
21-34-0008-1	CBL SIL 4-PIN .156 IN PITCH 6.0-IN	1
21-34-0021-3	CBL SIL 6-PIN .156 PITCH 10.0-IN	1
30-18-3030	CLIP GND PCB .30x.30x.07	3
30-51-0146	SHIELD PCB MT FOR 1/4 JACK 1.00 Hx1.25Wx.013THK BERYL COP	1
35-00-0059	PCB MAIN SPIDER2-HD75 A3-1 REV.A	1
45-01-0022	IC PROGRAMMED MCU v1.03 SPIDER2-HD75 A3-1	1
45-02-0023	IC PROGRAMMED FLASH v1.03 c/s=0x00DFDF95 SPIDER2-HD75 A3-1	1

50-02-0062 PCBA SPEAKER OUT SPIDER2-HD75

Part Number	Description	Qty Per
03-00-0101	CAP CER DISC 100pF 50V 5% TH	2
03-36-0102	CAP ESTR 1nF 100V 5% TH 7.2/2.5/6.5/5	2
21-00-6616	JACK 1/4" TRS 6-PIN PCB MT HORIZ TH	2
21-20-1564	HDR SIL PCB-MT 4-PIN X .156 MALE VERT-MNT FRIC-LOCK	1
30-18-3030	CLIP GND PCB .30x.30x.07	2
35-00-0062	PCB SPEAKER OUT SPIDER2-HD75 A3-1 REV.A	1

50-02-0065 PCBA SWITCH/LED SPIDER2-HD75

Part Number	Description	Qty Per
01-24-1300	RES 130R 1% 0805	5
01-24-4751	RES 4.75K 1% 0805	5
06-34-0016	DIODE SWITCHING 75V 200mA 6nS SOT-23 SM BAS16LT1	5
18-22-0003	LED YELLOW SUPER 2.0x1.2x1.1mmAP2012SYC SM	5
21-21-0014	HDR DIL PCB-MT 14-PIN 2x7x.100MALE SHRD VERT MT TH	1
35-00-0059-1	PCB SWITCH-LED SPIDER2-HD A3-1REV.A	1

50-02-0066 PCBA POWER AMP w/HEATSINK SPIDER2-HD75

Part Number	Description	Qty. Per
30-00-0010	SCREW 8-32 x 9/16 SKT-CAP S-STL	1
30-00-0028	SCREW 8-32 x 5/16" SHCS	1
30-03-0002	WASHER #8 .293 x.174x .040 STEEL	2
30-06-0007	NUT .344 HEX 8-32 STEEL ZINC	2
30-51-0059-3	HEATSINK 4.0 IN LG AL ALY BLK ANODIZE	1
30-51-0073	CLAMP HEATSINK TO-220 1.3x.45x.35" CR STEEL 1018	1
30-51-0105	BRKT SUPPORT .565 x .530 x .690 EG STEEL	1
30-63-0006	PAD THERMAL 6mil 25mm x 30mm w/ADHESIVE 4KVAC VTM-O	1
50-02-0061	PCBA POWER AMP SPIDER2-HD75 A3-1	1

50-02-0061 PCBA POWER AMP SPIDER2-HD75

Part Number	Description	Qty Per
01-00-0103	RES 10K 5% 0805	1
01-22-0R22	RES METAL OXIDE 0.22R 2W 5% TH	2
01-23-02R2	RES METAL OXIDE 2.2R 3W 5% TH FORMED LEADS @ 20mm SPACING	1
01-24-1693	RES 169K 1% 0805	1
01-60-0203	RES NETWORK ISOLATED 20K 16P 8R .3W 2% CER SOP-16 SM	1
03-18-0336	CAP ELEC 33uF 50V 20% RADIAL 5/11/5	1
03-18-1106	CAP ELEC 10uF 50V 20% BI-POLARRADIAL 6.3/11.2/5	1
03-22-0476	CAP ELEC 47uF 100V 20% RADIAL 10/15/5	2
03-24-0564	CAP MET-POLY 0.56uF 100VDC 5% TH 4.5/7.5/7/5	1
03-52-0470	CAP X7R 47pF 50V 10% 0805	1
03-52-0680	CAP X7R 68pF 50V 10% 0805	1
03-52-1103	CAP X7R 10nF 100V 10% 0805	2
12-30-7293	IC POWER-AMP 100W TDA7293 TO-220/15 TH	1
21-20-1566	HDR SIL PCB-MT 6-PIN X .156 MALE VERT-MNT FRIC-LOCK	1
21-20-1566	HDR SIL PCB-MT 6-PIN X .156 MALE VERT-MNT FRIC-LOCK	1
35-00-0061	PCB POWER AMP SPIDER2-HD7 A3-1REV.A	1

Reference Designator(s)
PACPKOUT Added ECO #0511202
PACKOUT

Reference Designator(s)
Mount chassis ASSY onto cabinet
Mount chassis ASSY onto cabinet
Place inspection label on the rear of chassis, on the right side of the headsink

Reference Designator(s)
CABINET ASSY - CORNER SCREWS
CABINET ASSY - HANDLE SCREWS
CABINET ASSY - RUBBER FEET
CABINET ASSY - BAFFLE BOARD SIDES AND BOTTOM
CABINET ASSY - BAFFLE BOARD SIDES AND BOTTOM
CABINET ASSY - HANDLE AND BAFFLE BOARD
CABINET ASSY - FRONT LEFT CORNER
CABINET ASSY - FRONT RIGHT CORNER
CABINET ASSY - TOP BACK AND BOTTOM
CABINET ASSY
BAFFLE BOARD
CABINET ASSY - TOP
CABINET ASSY - TOP

Reference Designator(s)
Mount to Chassis
See Assy Instruction
Power Cable - Fuse Holder
To Front Panel
Secures power amp PCBA to chassis
Switch PCBA to front panel
Secures plastic front panel to chassis
Secures transformer
To front panel of chassis
To front panel of chassis

To potentiometers
See work instruction
Onto Switch PCBA
To AC Assy
Main PCBA to chassis standoff, ground wire stud
To front panel

Reference Designator(s)
R65, R66
R54, R61, R64
R2, R8
R38, R39, R41, R43, R53, R55
R1, R56
R34
R45, R47, R49
R7
R63
R22, R23
R20, R21
R4
R9, R10, R67
R3
R31, R32, R33, R36, R37, R40, R60
R27
R44
R25, R26
R11, R16, R17, R24, R30, R35, R42, R59
C4, C5, C10, C12
C28
C8, C37
C30, C34
C18
C38
C6, C7, C14, C15
C20, C31, C32
C35, C36
C1
C23
C39, C40, C41, C44, C45, C46, C47, C48, C50, C51, C73, C74, C75, C76, C77
C9, C11, C13, C42, C43, C49, C53, C55-C60, C62-C65
C16
C72
C2, C3, C17, C19, C25, C27, C52, C54, C61, C66, C67, C68, C69, C70, C71
D21-D24

D28
D10, D15
D13, D14
D2, D18, D25, D26, D27
Q4
Q3
L1, L2, L3, L4, L5, L6, L7, L8, L9, L10
U11
U1, U9
U2
U6
U7
U5
J1, J3
J2
J4
H3
H2
H4
H5
H7
H1 (Connects to H6 on Switch PCBA)
H4 (Main PCBA) to H7 (Speaker Out PCBA)
H7 (Main PCBA) to H1 (Power Amp PCBA)
GF1, GF2, GF3
SH1
U3
U4

Reference Designator(s)
C20, C25
C24, C26
J5, J6
H7
GF1, GF2
Not Available

Reference Designator(s)
R6, R13, R15, R19, R29
R5, R12, R14, R18, R28
D3, D5, D6, D9, D11
D1, D4, D7, D8, D12
H6
(Breakaway of Power Amp PCB) Not Available

Reference Designator(s)
Secures clamp to headshink
secures bracket to headsink
Install betweek clamp & screw, bracket & screw
Secures clamp/screw & bracket/screw to headsink
Secures Pwr Amp IC to headsink
Mounts Pwr Amp PCBA to Headsink
Install between Pwr Amp IC and headsink
(Beakaway of Speaker Out PCBA)

Reference Designator(s)
R14
R7, R8
R6
R9
R10
C16
C12
C8, C10
C9
C13
C11
C14, C15
U2
H1
H1
(Breakaway of Speaker Out PCB) Not Available



Engineering

CONFIDENTIAL

Spider II Theory of Operation

September 24, 2003

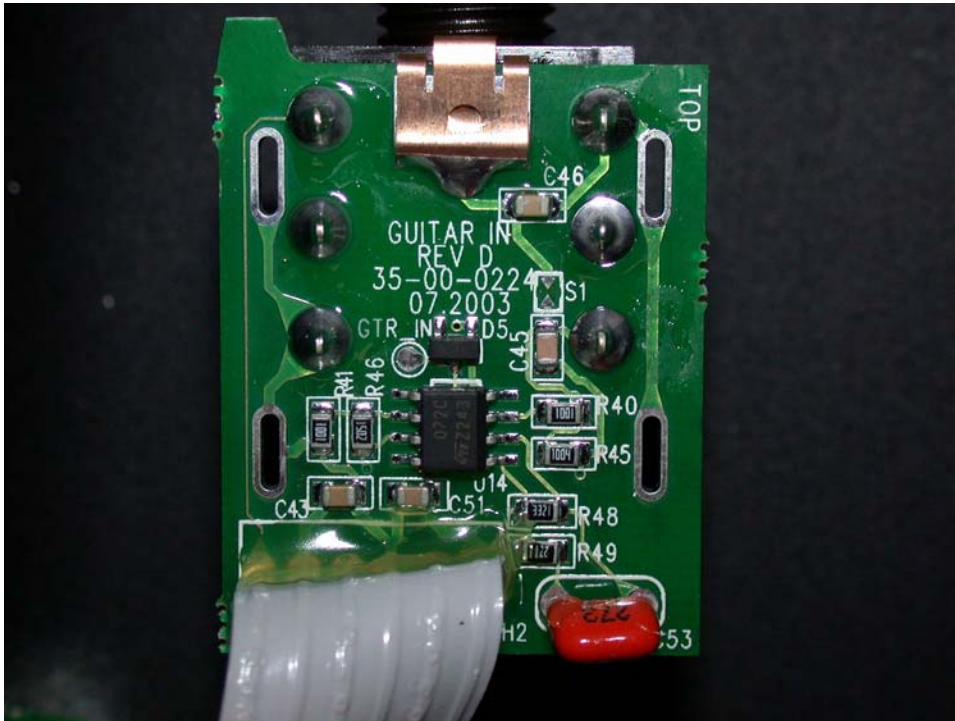

-The Spider II Guitar In PCBA-

Guitar In PCBA (see page 1 of the schematic):

Analog signal consideration:

An analog signal is input through jack J5, and is referenced to ground by R45, which establishes a 1Mega. Ohm input impedance. Maximum input signal amplitude before clipping is about 5Vpp(0 to 200Hz).

The signal then passes to U14-A, where the signal is buffered, and also amplified by the pre-emphasis filter in the feedback loop (R48, R49 and C53). This single-pole pre-emphasis filter adds gain starting around 200Hz. Maximum gain is about 8dB at 20kHz.

The output of U14-A is the “low gain” analog signal and is sent to the Main PCBA (IN_LEFT), and it is also sent to the input of U14-B.

U14-B increases the “low gain” signal by a gain of 16, and this resulting “high gain” signal is then sent to the main PCBA (IN_RIGHT).

Digital signal consideration:

The GUITAR_SENSE' signal, which is sent to the main PCBA, indicates the presence of a jack plugged into J5. This signal is created by: J5 and the pull-up resistor R16 on the main PCBA. The signal is low if there is no jack, and high if a jack is plugged in.

EMI consideration:

C45, C46 and GF1 help to shunt HF noise to the chassis and AGND' appropriately.

ESD consideration:

S1, GF1 and C46 provide a low-impedance HF shunt to chassis ground for ESD. D5 is a voltage clamp, and helps insure that ESD will not exceed the voltage rails of U14. R40 provides over-voltage current limiting for both D5 and U14.

Main PCBA

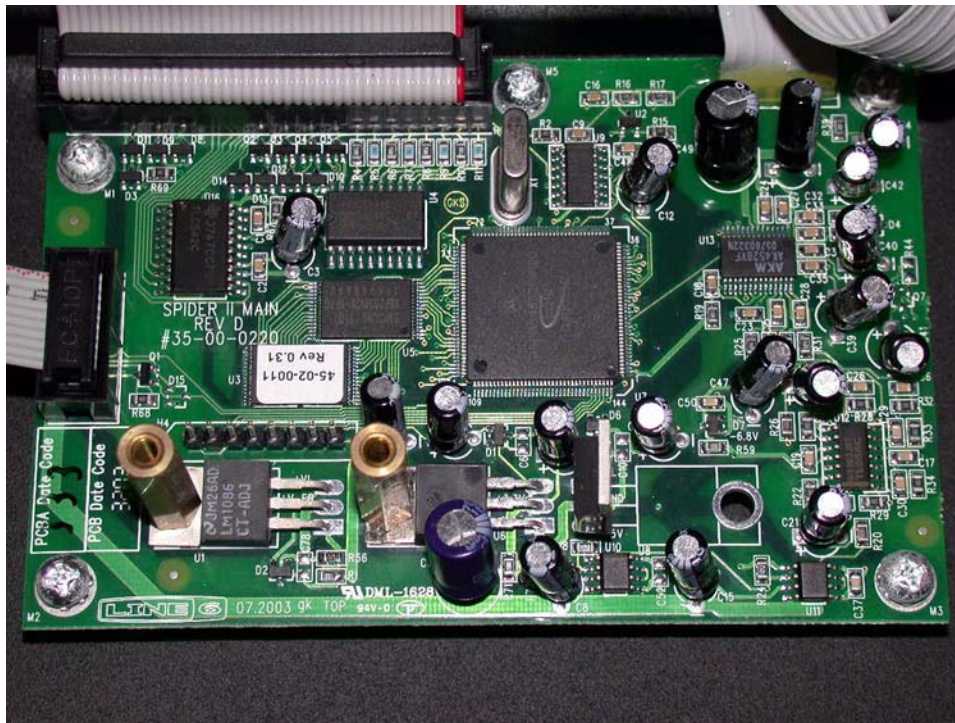

-The Spider II MAIN PCBA-

Power supply:

Power required by the Main, Guitar In, and User Interface PCBAs is provided by the local supply on the Main PCBA.

+VL and -VL (around +10.5VDC, -7VDC) arrive from the power supply PCBA via the cable connected to H1 on the Main PCBA.

There are four discrete supplies derived from +VL and -VL. They are: +V_FB (+9VDC), +5V, +3.3V and -6.8V. Please reference page 5 of the schematic.

+V_FB is the source for the floorboard connection on the User Interface PCBA and also the +3.3V supply. It is mainly comprised of U1, an adjustable voltage regulator. The output of U1 is determined by the two resistors R1 and R56. D2 provides over-voltage and under-voltage protection, while C77 provides filtering.

+5V is produced by U8, a linear regulator. D6 provides over-voltage and under-voltage protection, while C14 provides filtering. The +5V supply is also further filtered by R54, R55 and C41 (schematic page 2) to provide +5VA, which is the positive source for the analog input circuitry. On the same page, R54, C24 and C20 provide a local analog supply for the codec, U13. On page 4 of the schematic, the +5V rail is also filtered by R67 and C1 to create +5V_AD, which is the source for the A/D converter and the User Interface PCBA potentiometers.

+3.3V is produced by U6, an adjustable voltage regulator. The output of U6 is determined by the two resistors R71 and R72. D1 provides over-voltage and under-voltage protection, while C5 provides filtering.

-6.8V is the negative source for the analog input circuitry, and it is generated mainly by the voltage drop across D7, a zener diode. R59, C31, C47 and C50 provide filtering.

Analog signal consideration:

(See page 2 of schematic)

Inputs to ADC:

The “high gain” and “low gain” analog signals arrive from the Guitar In PCBA via the 6-conductor cable attached to location H3. The low gain signal IN_LEFT is connected to the left input of codec U13 via R39 and C44, and the high gain signal IN_RIGHT is connected to the right input of codec U13 via C42, R38, and R35. The series capacitors on each input are used as “DC blocking” capacitors since the analog inputs of U13 are biased to approximately ½ of its analog supply, or 2.5V. On the right channel “high gain” input to U13, a diode D4 is used to “clamp” the voltage to a safe level (-0.6V and +5VA+0.6V) since this channel is usually clipping with a nominal signal present at the input (R Ch. clipping starts around 0.31Vpp at input).

The resistors and capacitors (R50, R51, C39, C35 on LIN- and R37, R36, C40, C35 on RIN-) connected to the negative (-) inputs of U13 help ensure that each input is biased to ½ of the codecs supply (approximately +5VA).

The ADC of U13 converts the left and right analog signals into digital signals, which are then sent to the DSP (ADC_DATA) for processing. Only one of the signals is chosen based on amplitude, before it is processed. The processing includes a digital de-emphasis filter to compliment the analog pre-emphasis filter.

Outputs of DAC:

The codec receives the processed digital audio signal from the DSP at its serial data input (DAC_DATA). The codec then converts the digital signal into analog signals, which are output on pins 25-28 of U13.

The analog outputs of codec U13 are differential, and have a DC bias of approximately $\frac{1}{2}$ +5VA (about 2.5V). These differential analog signals are passed to U12-A and B, which is configured as a low-pass filter with gain of around 1.66. The frequency cutoff for the LPF is well above the audio pass-band. ($f_c > 20\text{kHz}$) and is intended to reduce EMI. The resulting outputs of U12-A and B (+AUDIO_L and +AUDIO_R) are single-ended, and in-phase with the systems input. Since the power amplifier needs a differential signal (+/-AUDIO_L/R signals sent to power amplifier via H1 [page5]), and the headphone amplifier inputs require an inverted signal, amplifiers U12-C and D are configured to create the inverted audio output signals (-AUDIO_L and -AUDIO_R).

Headphone amplifiers:

The -AUDIO signals go to the headphone amplifiers U10 and U11. Although these are stereo amplifiers, a single amplifier is used for each output channel. This is because a mono jack plugged into the headphone output could potentially cause both channels of the amplifier to thermally shut-down. Using separate amplifiers, the un-shorted amplifier(s) are unaffected by this condition. C21 and C22 are “DC-blocking” capacitors, since the inputs of each amplifier are biased to about 2.5V. R18, R20, R24, and R26 provide gain of 5.2 for each amplifier. C8 and C15 are bypass capacitors and filter the bias voltage for the inputs and outputs. The “DC blocking” capacitors for the headphone amplifiers are located on the User Interface PCBA.

Digital signal consideration:

(See page 3 of the schematic)

The system reset is provided by U2, and is active low. All other peripheral reset and enable signals are provided by U7. The DSP U7 provides system control, input/output, and processing of the audio signals.

Clocks:

The 2MHz system master clock is composed of the components connected to pin 55 (EXTAL) of U7. All other clocks are generated from the master clock within U7, using a PLL. The filter for the PLL is made up of the components connected to pins 45 and 46 of U7.

Codec clocks:

The codec clocks are generated by U7. Since the system sampling frequency (f_s) is 39.0625 kHz, this is the frequency of the LRCLK. BCLK is the bit clock and runs at a speed of 64 f_s , or 2.5MHz. Finally, the codec master clock, or MCLK, runs at 256 f_s , or 10MHz.

Memories:

There are two memories (U3 and U5) connected to the DSP via the 18-bit address bus, and the 8-bit data bus respectively. The flash memory, U3 holds the system code, and is loaded into the DSP after U2 removes the master reset. The other memory, U5 is an SRAM, and is used for buffering processed audio signals.

DSP interface to User Interface PCBA: (See pages 3 &4 of schematic)

FBV: The floorboard signals are buffered through U9, the same buffer, which is used in the master clock oscillator. The signals are serial differential output and input. Diodes D3,8,9,11 provide ESD/over-voltage protection for U7 and U9.

LEDS: The current source for the LED matrix on the UI PCBA is U4, a line driver which drives the LEDES with a 5VDC signal (~25%D.S.). Resistors R4-11 limit current to the LEDES. DSP port pins control the inputs of U4 directly with a refresh rate of around 10ms. The current sink for the LED matrix is the four individual MOSFETS Q2,3,4,5. Diodes D10,12,13,14 are used for ESD protection.

ADC for UI: U16 is an eleven channel ADC, which converts voltage levels for all potentiometers and button switches on the User Interface PCBA. This ADC is interfaced to the DSP via the SPI bus, and has a “read rate” of about one channel every 500us.

JTAG: The JTAG port of the DSP is available through the uninstalled H4 header. This connection is used for development and in-house software upgrades.

Control/sense lines:

/MUTE: Is the signal, which is used to mute the power amplifier, and is level-translated from 3.3V to +VL (around 7+V) by Q1 and R68.

HP_SENSE: Is an active high signal, which indicates if a jack has been plugged into the headphone jack on the UI PCBA. The signal is generated by R65 and the HP jack.

GUITAR_SENSE: See Guitar In PCBA above.

MONO/STEREO: Is a signal from the power amplifier indicating its configuration. A mono configuration is indicated by a “high” and a stereo configuration is indicated by a “low”.

SPIDER II SYSTEM FLOWCHART SEP. 30, 03

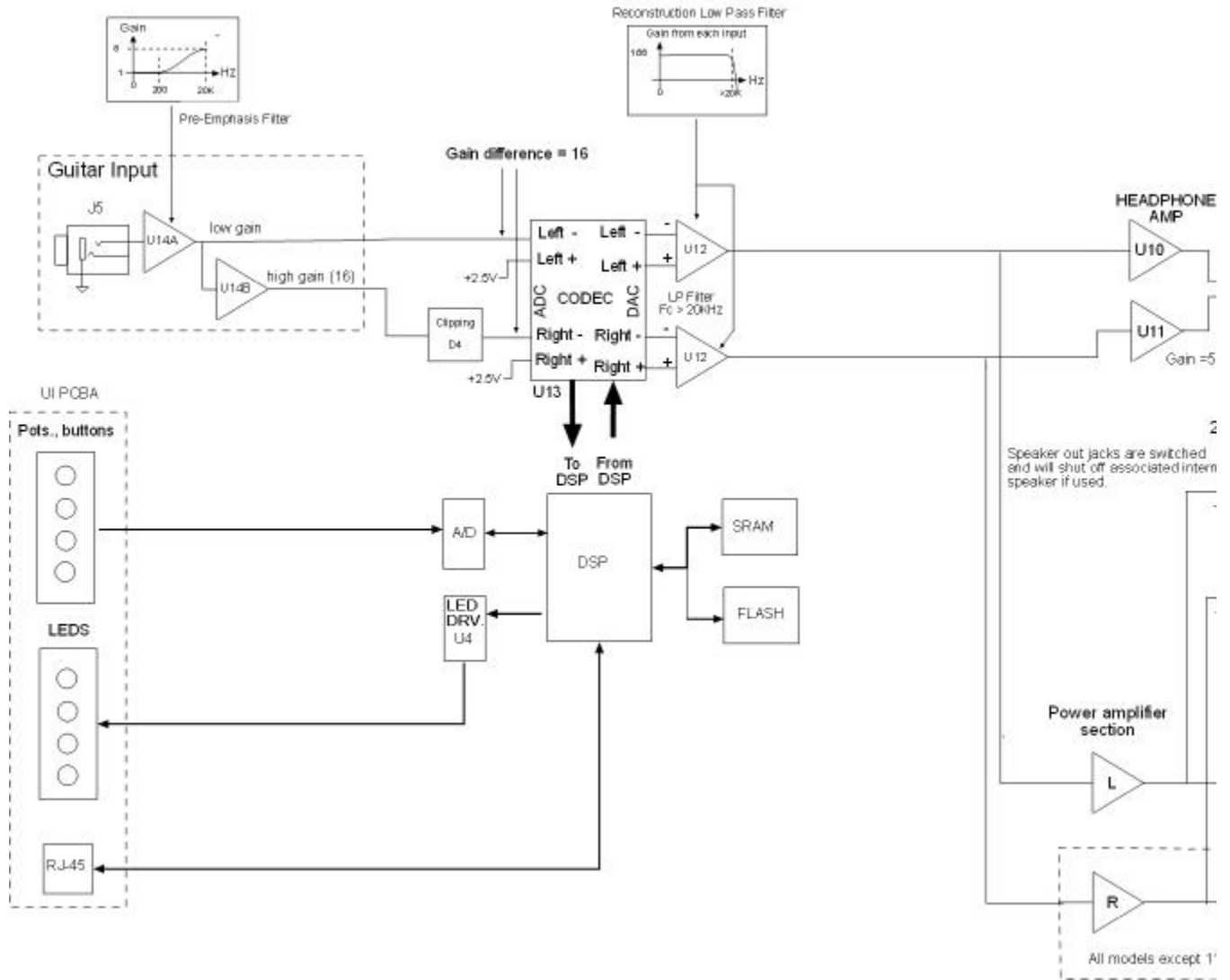

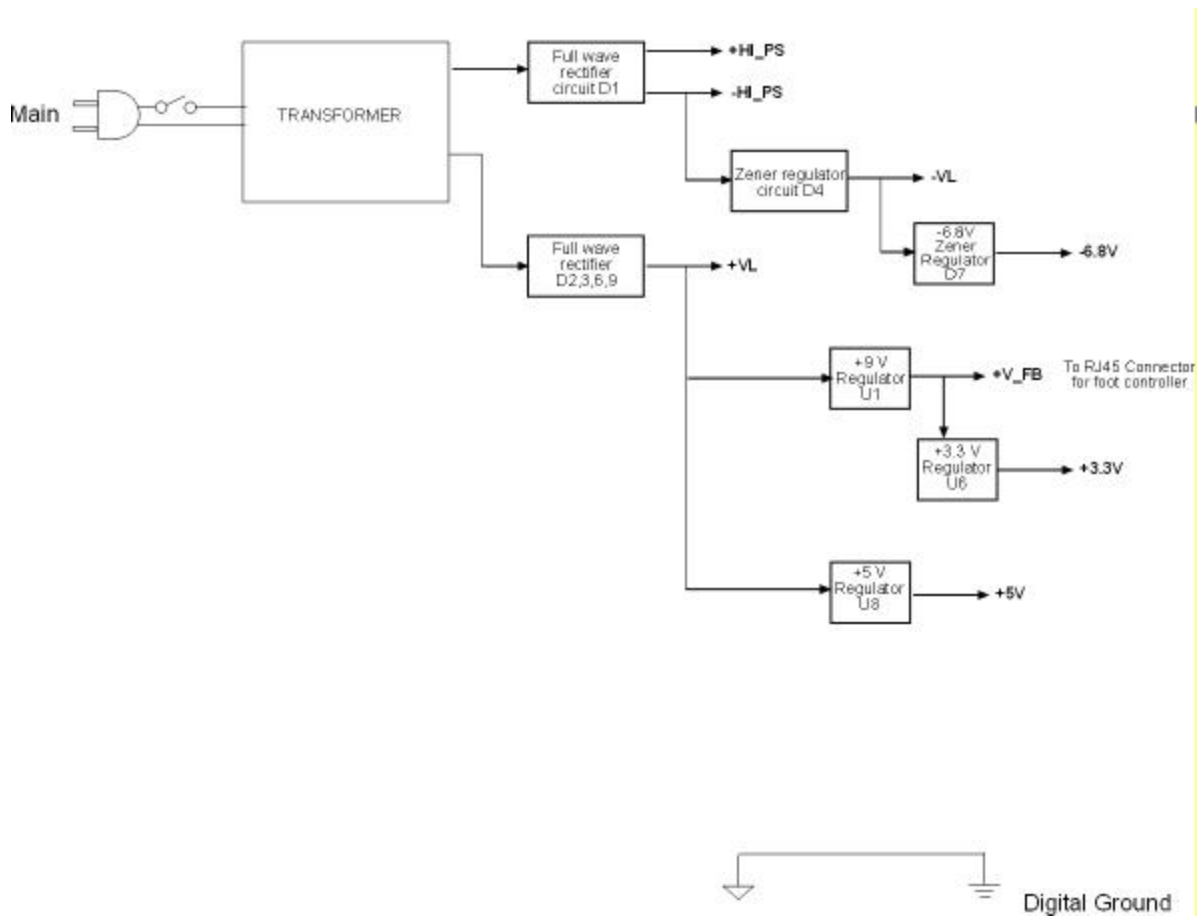

Troubleshooting Guide – Spider II

This section outlines some common problems that may be encountered when troubleshooting a Spider II.

1. The FLASH memory on the Spider II MAIN PCBA is updated with any setting changes (e.g. knob change, etc...) that occur at any time. It is not the same as the 7-second rule used on the POD XT and POD XT Pro. So if any settings are not being saved. Check for faulty soldering or components on the DSP's memory bus (which includes the DSP U7, the FLASH U3, and SRAM U5) especially the FLASH U3.
2. The board is powered up but the rest of the system is frozen (e.g. no LED's, no POTS or buttons work, no audio, etc). First, check that the crystal X1 is generating the 2MHz clock. This can be checked at U9 pin 6. Second, check for faulty soldering on the DSP's memory bus. Finally, check for faulty components on the DSP bus side or if possible check that the FLASH U3 is programmed.
3. The board powers up, the UI is displaying the correct items, the buttons and knobs work, but there is NO AUDIO. First, check the audio input circuitry and make sure audio makes it through the input op-amp U14 (on the guitar input PCBA) all the way to the CODEC U13 inputs. Second, make sure that the CODEC has the appropriate clocks driving it (See section CLOCK SYSTEM above). Third, check the audio path from the output of the CODEC to the power amp and the headphone circuitry. Fourth, check that the signal GUITAR_SENSE is HIGH (HIGH means that a jack is plugged into the Spider II's guitar input.). If this signal is not HIGH then the guitar in jack J5 or the support circuitry for the sense line is faulty. If the system thinks that a plug is not plugged into the guitar jack it will automatically mute the audio. Fifth, the audio is correct all the way to the CODEC and the clocks are correct then it is possible that the DSP or an item on its bus is malfunctioning. At this point check for faulty soldering on the DSP or other items on its bus. Sixth, the audio is correct all the way to the power amp but no audio out of the power amp. Check that the mute circuitry for the power amp is functioning properly. Finally, the audio is correct all the way to the HEADPHONE amps but no audio out the headphone out. Check the headphone amp circuitry. Remember, there are two headphone amp IC's one for the left and one for the right output which go to the tip and ring respectively on the headphone output jack on the break-away. You may also want to check that the HP_SENSE line on the MAIN PCBA is not LOW when the jack is plugged in.
4. The LED's work, but the POTS & BUTTONS do not. First, check if you can get into test mode by powering down and then power up while pressing the TAP TEMPO button. (If you are able to get into test mode you will see the Channel A and D LED's light up GREEN and the Channel B and C LED's light RED. If this happens run the POTS & BUTTON TEST by pressing the Channel B button and isolate the switch or pot that is not working). If you are not able to get into test mode check that the support circuitry for the switches is functioning properly and that the signal SW is getting from the ADC U16 on the MAIN PCB to the switch circuitry on the UI PCBA. Check that the ADC U16 on the MAIN PCB is getting the clocks and/or signals from the DSP.

5. The board seems to be working properly but the LED's do not work. First power down and then power up in test mode (Press and hold the TAP TEMPO button on power up, then press the Channel A button to run the LED Test). If the LED's fail in test mode check the LED_COL[1:8] lines coming from the octal buff driver U4 or the DSP and the LED_ROW[1:4] lines coming from FET's Q2-5 or from the DSP.
6. The board is running but the RJ-45 interface to floorboard (FBX, FBV, FBC, etc.) does not work. Check for faulty soldering on the DSP, IC U9, etc... Also, check that signals from the DSP or IC U9 are getting to the HEADPHONE_RJ45 breakaway PCBA along with the 9V supply rail +VFB.

Additional Tips:

- ❑ Use the proper speaker cable connector on the 212 (use the speaker output PCB connector H7 rather than the one on the power supply PCB) when putting the amp back together.
- ❑ Pay attention to the fact that there is a bi-polar electrolytic cap on the power amp (I don't believe we use these caps in any other product).
- ❑ Be careful to not twist too much the soldered ribbon cables (guitar input PCBA to main, RJ45 breakaway to UI, power supply to power amp, and on 212\HD power amp to speaker out PCB).
- ❑ Point at a convenient grounding point for scope (I.e. the +5V regulator heat sink tap)
- ❑ Clearly understand the different AC voltage wiring configurations.
- ❑ Be very careful to fully remove the head mounting screws before re-installing the head in the cabinet to avoid scratching the front panel paint.
- ❑ Make sure that the guitar input PCB index is in the metal work slot before tightening the jack's nut.



SPIDER II, CHASSIS & FRONT PANEL ASSY INSTRUCTIONS
HD75
Rev B
L6D000034

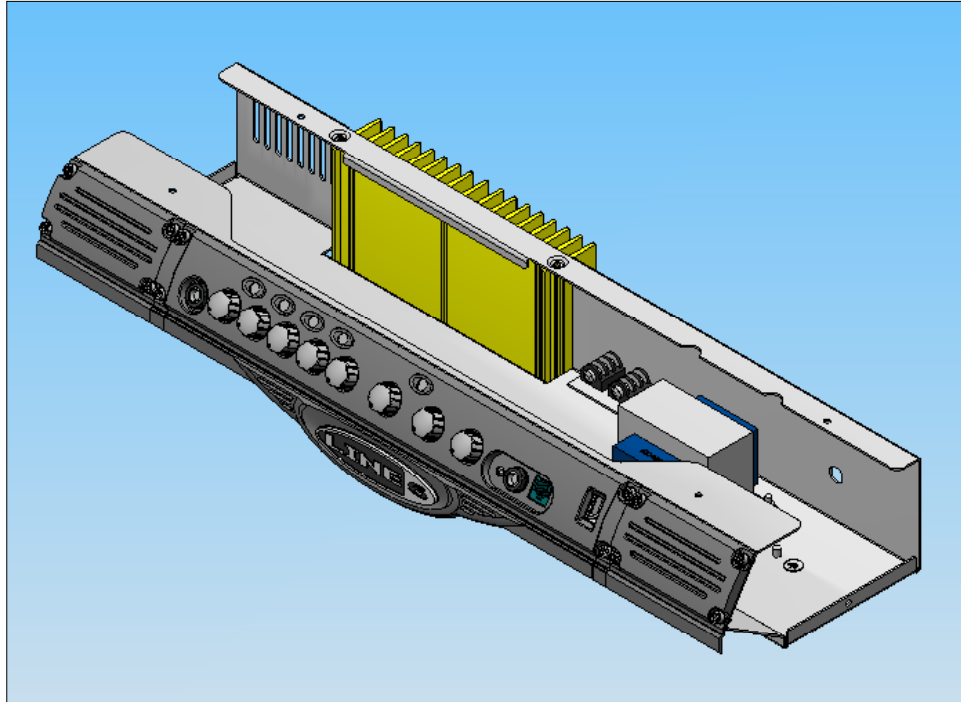

Forward and Notes

The information in this booklet applies to the mechanical assembly of the Spider II HD75 chassis and front panel.

See also the Related Electrical assembly documentation, for major considerations in assembling the electrical components of the PCBs (through the soldering process and preparation of the board for addition of custom components).

A note on the text: the illustrations in this book are for reference only. In some cases, color and geometry of illustrations may not accurately reflect the color or exact geometry of actual parts.

- Unless otherwise noted, all dimensions are in inches.
- Part identifying notes are in this format: Description (Part Number)
- Drawings are not to scale.
- Torque value tolerance +/- .5 in.-lbs. Do not over tighten any components.

For clarity, not all component details are shown. This is especially true with respect to cable assemblies. They are often omitted from views to provide a clearer picture of the material discussed. Do not be confused by the absence (or unexpected presence) of any component in the illustrations in this book.

STEP 1

Install Power switch (24-24-0606). The switch should snap securely into place with the "I" above the "O".



STEP 2: Clip tabs and break away Switch PCBA (35-00-0059-1)

Switch PCBA (35-00-0059-1)



STEP 3: Install Main PCBA (P/N 35-00-0059) into chassis.

Secure Main PCBA to chassis by installing 6-32 screw (30-00-0043), to chassis PEM stud. **IMPORTANT: Only partially tighten screw.**

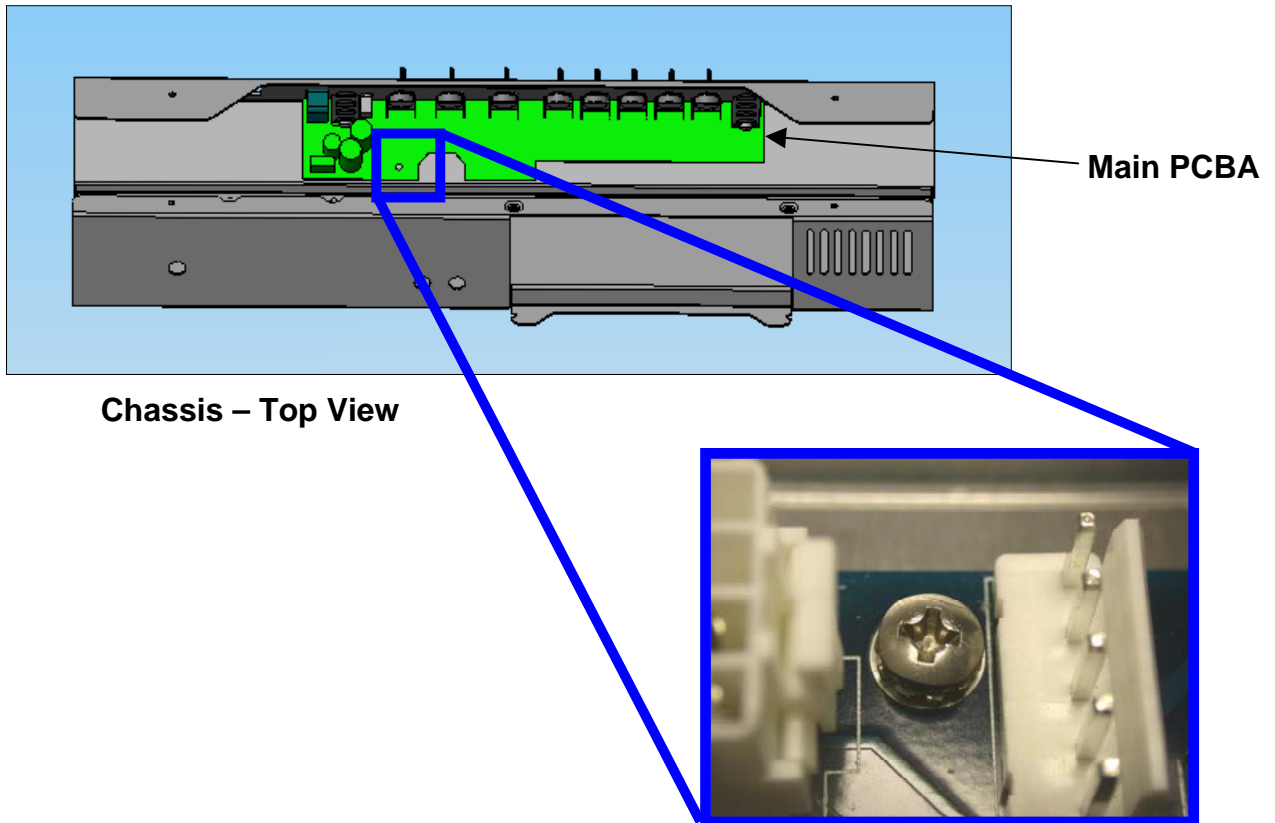

STEP 4: Install Switch PCBA (P/N 35-00-0059-1) to front panel using three, 6-32, 3/8" screws (Line 6 P/N 30-00-0375). Torque 8-10 in/lbs. Apply Loctite P/N 21463 (Threadlocker 222) or equivalent, to exposed screw threads after assembly.



THE NEXT STEP IN THE ASSEMBLY PROCESS REQUIRES THE ASSEMBLER TO TAKE PROPER ESD PRECAUTION DUE TO THE STATIC SENSITIVE DEVICES ASSOCIATED WITH THIS ASSEMBLY.

STEP 5: Install Heat Sink/w Power Amp PCBA (P/N 50-02-0066) using four (4) #6-32 self-tapping screws (P/N 30-00-0018).

Note – Remove any metal debris that may have been introduced during installation.

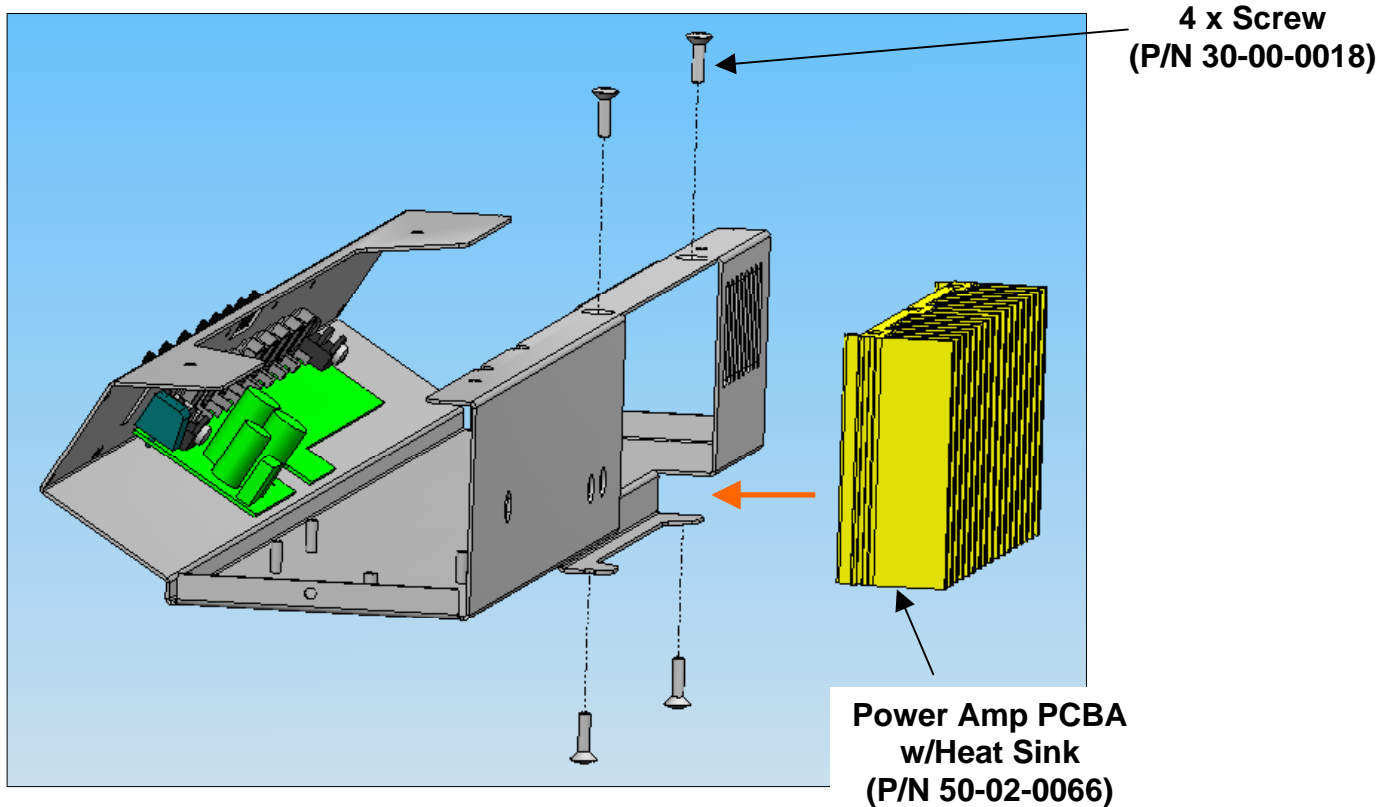

STEP 5a: Install 21-34-0021-3 (10 inch 6-pin cable) between Power Amp PCB (P/N 50-02-0066) and Main PCBA.

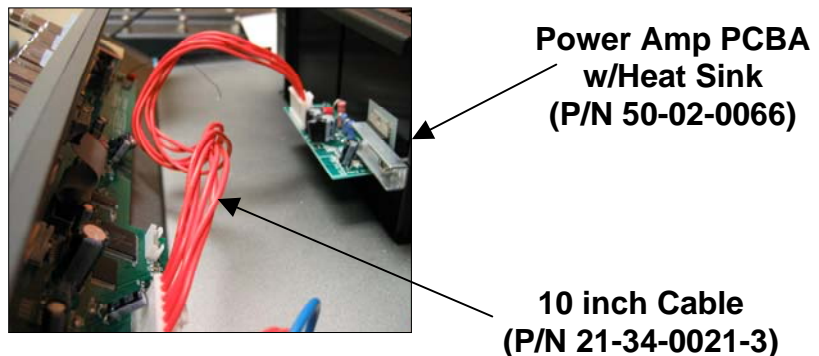

Step 6: Install Speaker Out PCBA (50-02-0062) using two ¼" Jack Nuts (21-00-6616). Torque to 4 in/lbs.

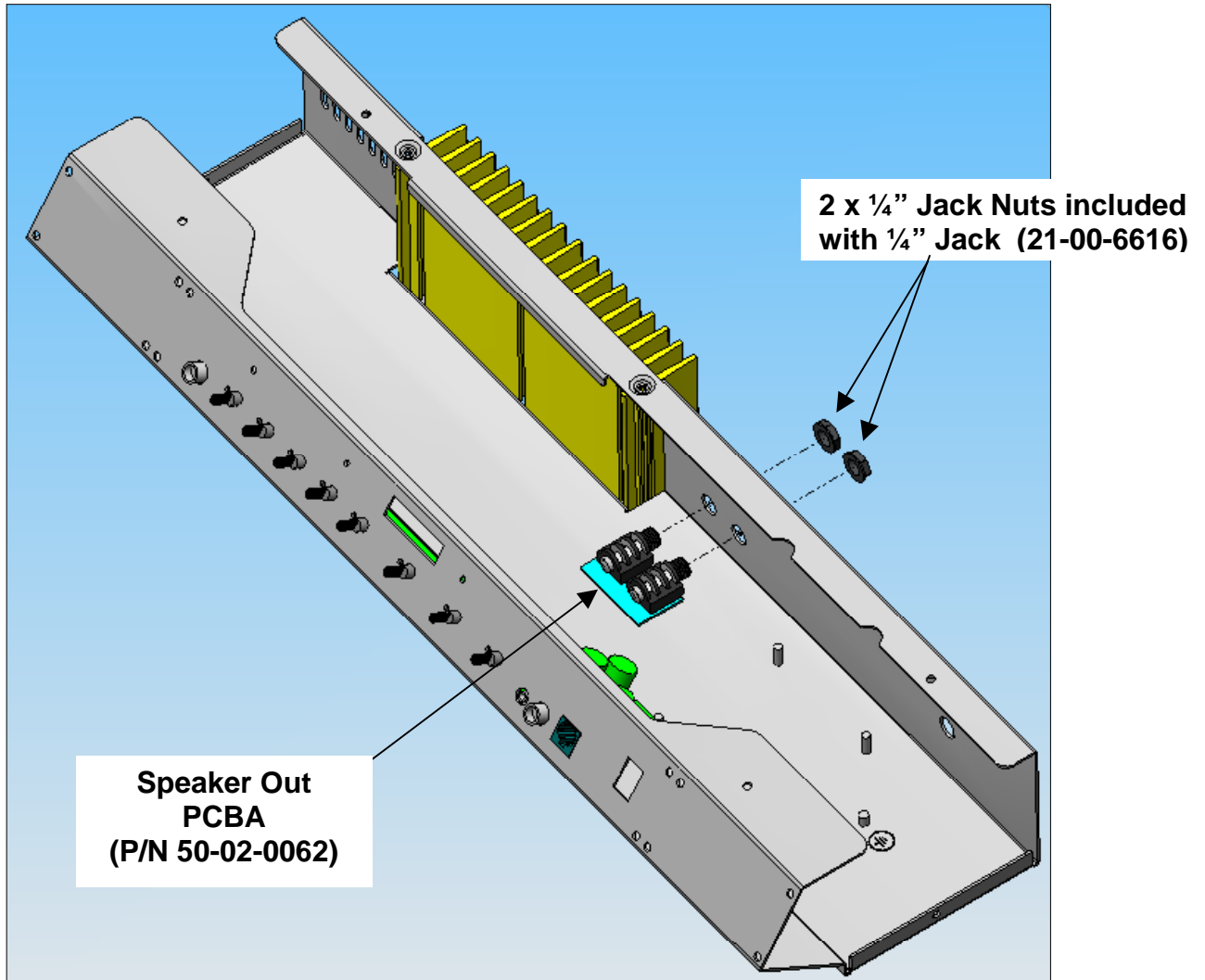

STEP 6a: Install 21-34-0008-1 (6 inch 4-pin cable) between Speaker Out PCBA (P/N 50-02-0062) and Main PCBA.

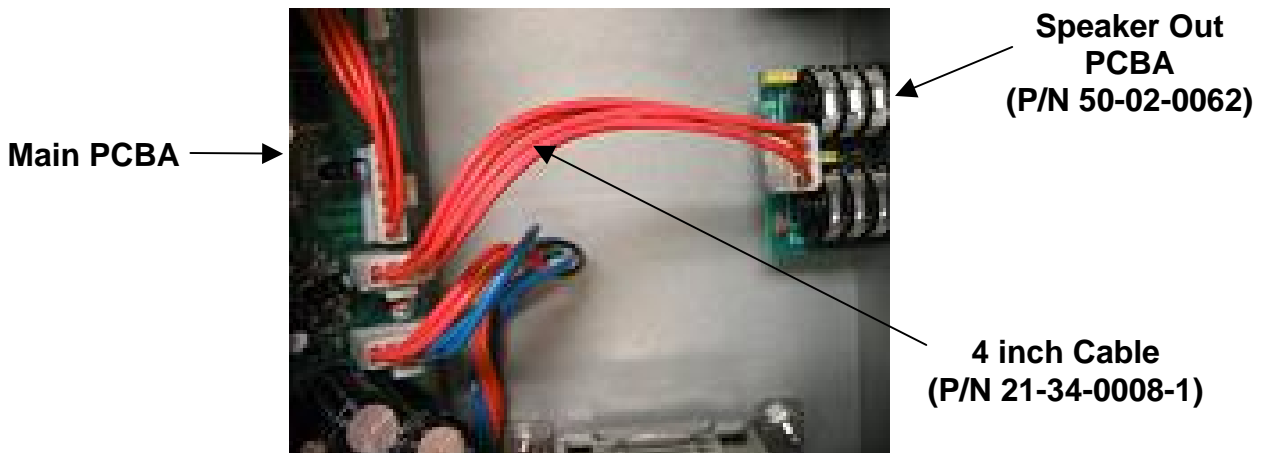

STEP 7: Cut red or yellow transformer wire. Cut wire as close to transformer body as possible. Use the table below to determine what wire to cut.

Finished Goods P/N	Transformer Part Number	Cut Red or Yellow Transformer Wire
59-00-0006-1 (Spider II HD75 – 240V AU)	11-30-0026	Cut Yellow Wire
59-00-0006-2 (Spider II HD75 – 230V EU)	11-30-0026	Cut Red Wire
59-00-0006-3 (Spider II HD75 – 240V UK)	11-30-0025	Cut Yellow Wire
59-00-0006-4 (Spider II HD75 – 120V US)	11-30-0026	Cut Yellow Wire
59-00-0006-5 (Spider II HD75 – 100V JA)	11-30-0025	Cut Red Wire

Cut Yellow Wire for 120/240VAC Units

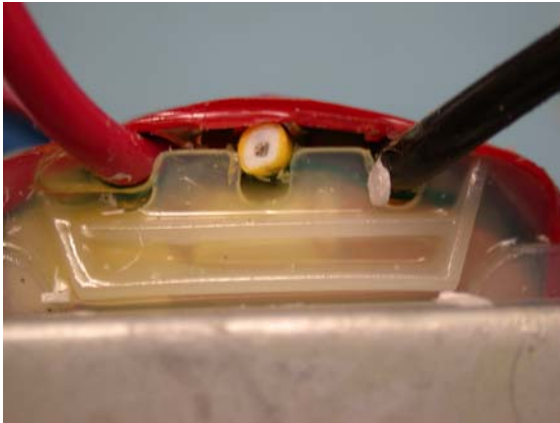

Cut Red Wire for 100/230VAC Units

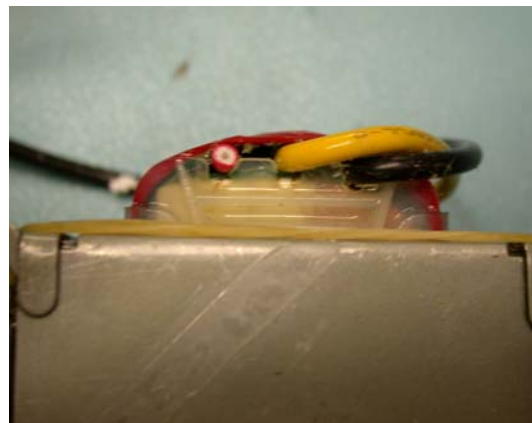

STEP 8: Install transformer into chassis as shown in picture below. Secure transformer to chassis using four hex nuts (30-06-0832). Torque to 12 in/lbs. Apply Loctite P/N 21463 (Threadlocker 222) or equivalent, to exposed screw threads and hex nuts after installation.

Insure that primary leads (black, yellow and red) of transformer are toward the rear of chassis.

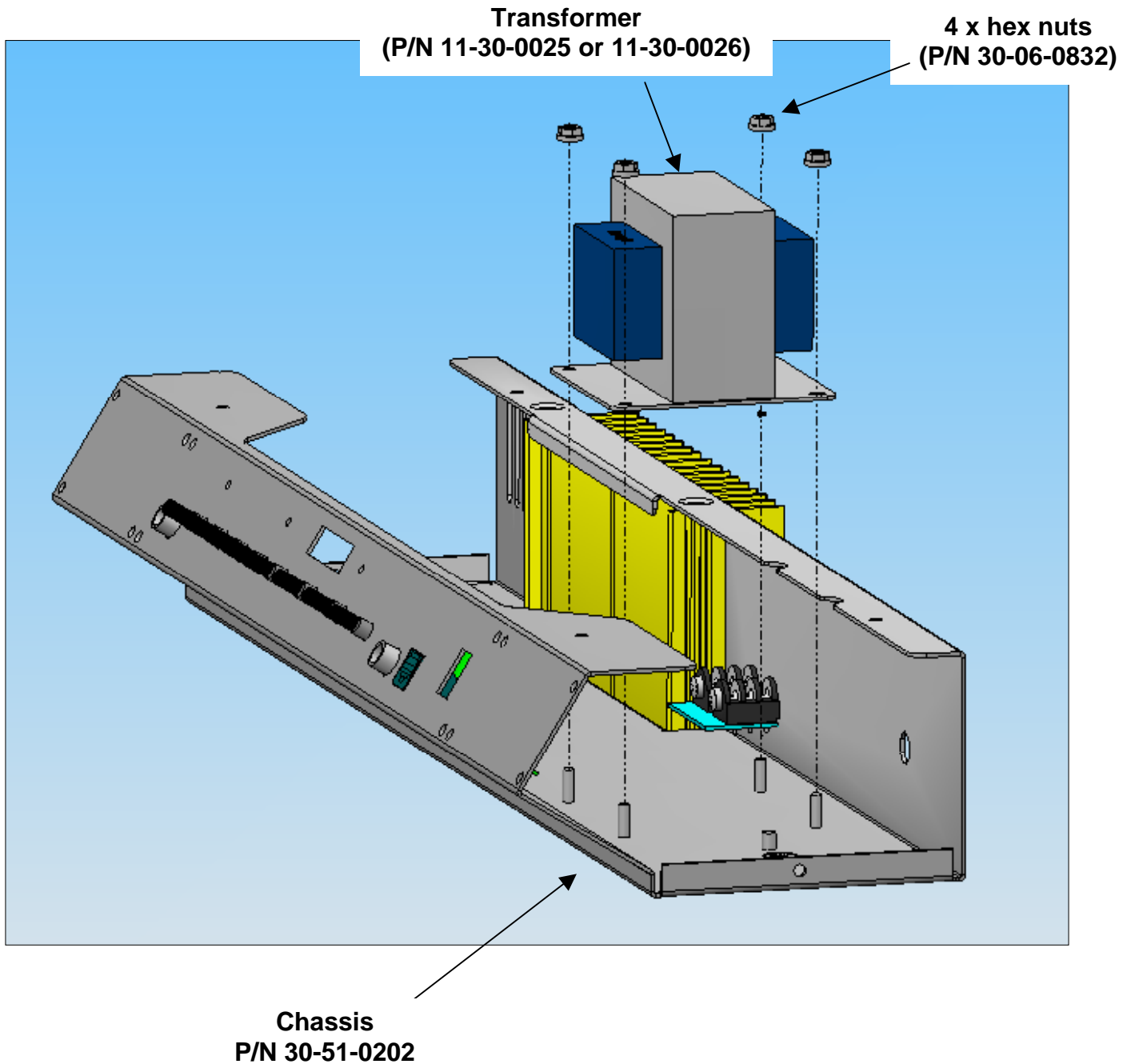

STEP 9: Connect transformer secondary wires (5-pin connector) to H5 on Main PCBA.

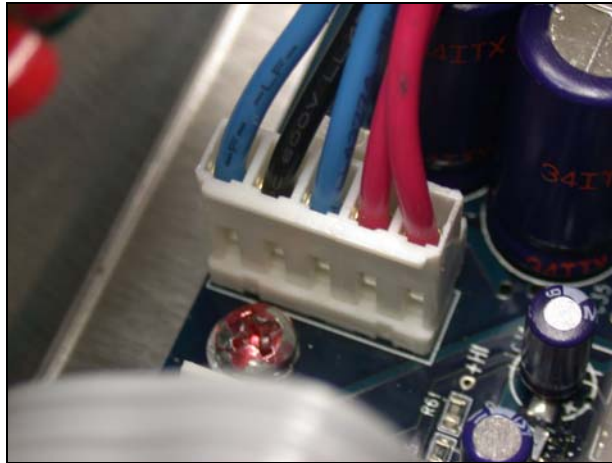

STEP 10: Install strain relief bushing (30-75-0021) on AC cable assembly, P/N 21-37-0001-X, .200-250Mils from end of cable. The "X" in the AC cable assembly part number, indicates the country where the AC cable assembly is used. See TABLE 1 on AC cable assembly drawing 21-37-0001. Note that only -5 through -8 configurations (8 ft long) will be used for this assembly.



STEP 11: Insert ends of AC cable through rear of chassis. Compress strain relief, using appropriate tool, and insert into chassis. The strain relief bushing must be oriented, as shown in the picture, for proper installation.



STEP 12: Connect green/yellow ground wire to PEM stud in chassis using a 6-32 screw (30-00-0043). Torque 8 in/lbs. Apply Loctite P/N 21463 (Threadlocker 222) or equivalent, to screw and PEM stud after installation.

Chassis – Isometric View

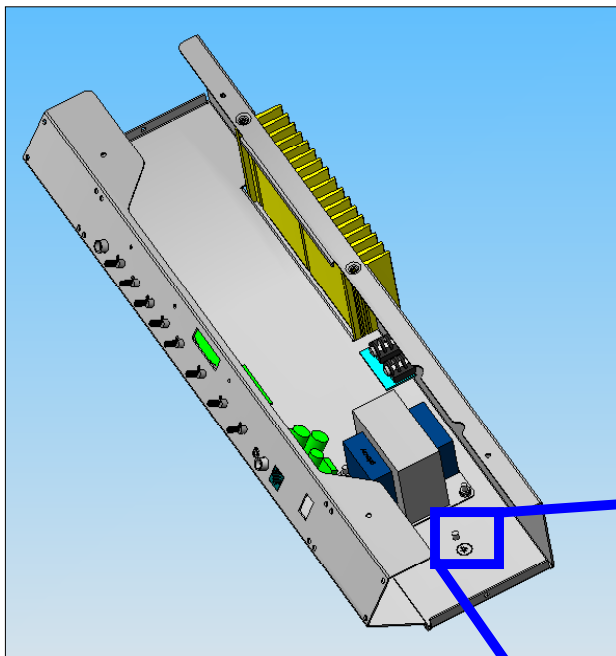

Screw (30-00-0043)

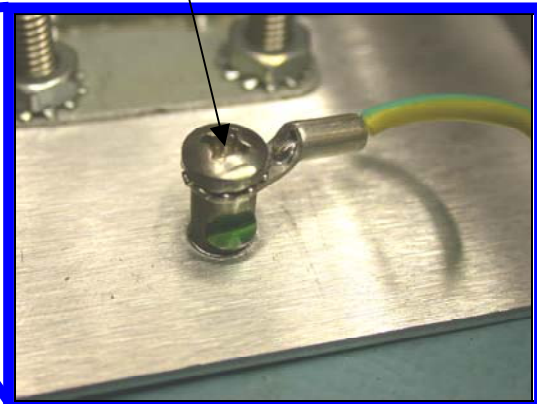

STEP 13: Open fuse holder, install fuse, close fuse holder. Make sure there is a spring inside the fuse holder. Use the table below to determine the fuse value.

Finished Goods P/N	Use 2A/250V Fuse Fuse (24-18-2251)	Use 4A/250V Fuse (24-19-4025)
59-00-0006-1 (Spider II HD75 – AU)	X	
59-00-0006-2 (Spider II HD75 – EU)	X	
59-00-0006-3 (Spider II HD75 – UK)	X	
59-00-0006-4 (Spider II HD75 – US)		X
59-00-0006-5 (Spider II HD75 – JA)		X



STEP 14: Connect black transformer wire to top terminal on power switch. Connect brown or black fuse holder cable, to bottom terminal on power switch. Secure both cables together with a cable tie (30-24-0003).

Black Transformer Wire

**Brown or Black
Fuse holder cable**

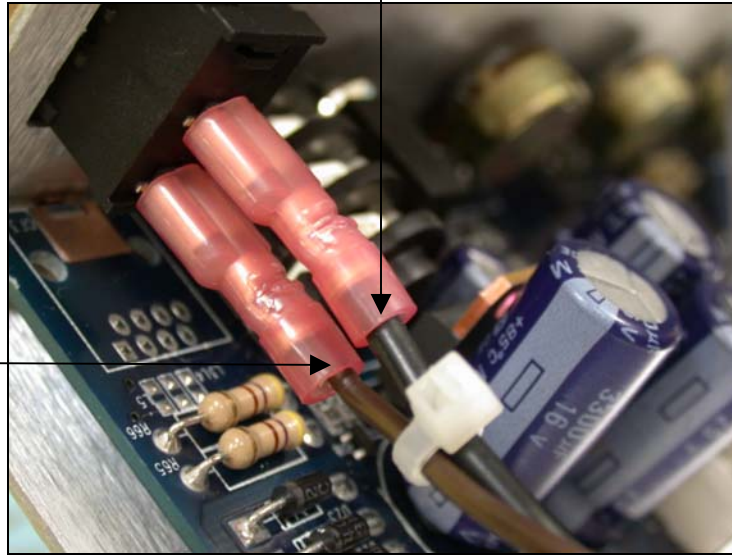

STEP 15: Connect Red or Yellow transformer wire to blue or white AC cable wire. There should only be a red or yellow cable available since the other cable was cut in STEP 12.

Finished Goods P/N	Use Red Transformer Wire	Use Yellow Transformer Wire
59-00-0006-1 (Spider II HD75 – AU)	X	
59-00-0006-2 (Spider II HD75 – EU)		X
59-00-0006-3 (Spider II HD75 – UK)	X	
59-00-0006-4 (Spider II HD75 – US)	X	
59-00-0006-5 (Spider II HD75 – JA)		X

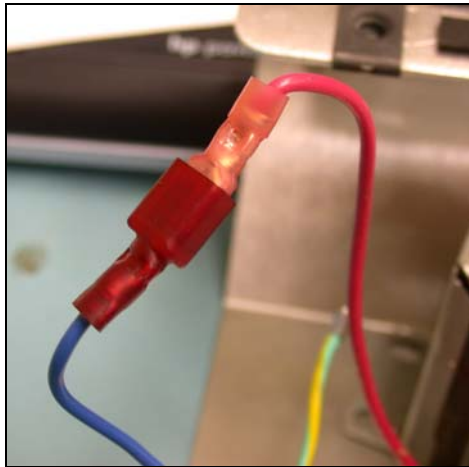

STEP 16: Use a cable tie (30-24-0003) and secure all wires together.

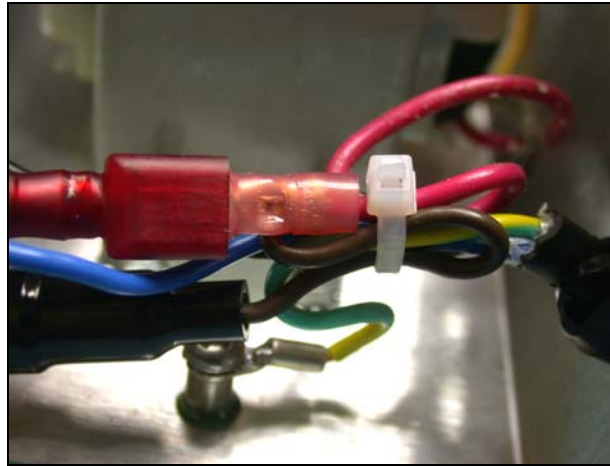

STEP 17: Install two adhesive foam strips (30-63-0010) on top and front of chassis. Cut strips to cover chassis approximately as pictured below.

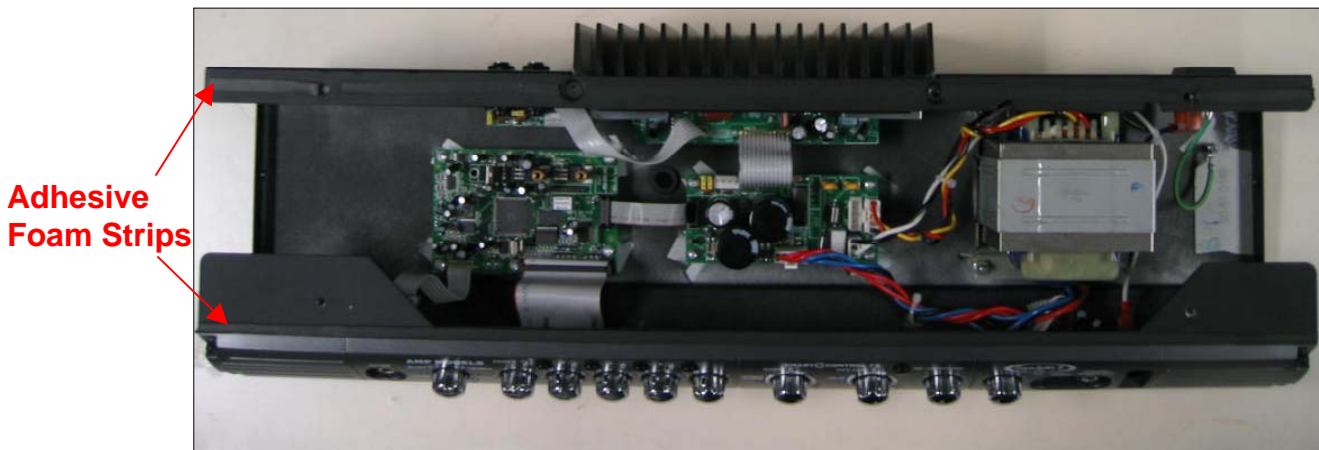

Top View



Front Panel View

STEP 18: Install rubber keypad (30-75-0020) onto Switch PCBA (P/N 35-00-0059-1).



STEP 19: Install Line 6 logo (40-25-0018) onto front panel (30-27-0156). Note that the front panel will be part marked with a different part number (30-27-0104) on the back, but should be silkscreened with "Spider II HD75" on the front.



STEP 20: Install two (2) four inch long adhesive foam strips (30-63-0010) to back surface of front panel (30-27-0156) approximately as shown. Note that the front panel will be part marked with a different part number (30-27-0104) on the back, but should be silkscreened with "Spider II HD75" on the front.



2 Foam strips
(30-63-0010)

STEP 21: Install plastic front panel (30-27-0156) onto chassis and secure with four 10-32 x 3/8" screws (30-00-1033). Note that the front panel will be part marked with a different part number (30-27-0104) on the back, but should be silkscreened with "Spider II HD75" on the front. Torque screws 3-4 in/lbs

Install hex nut at each corner of front panel.

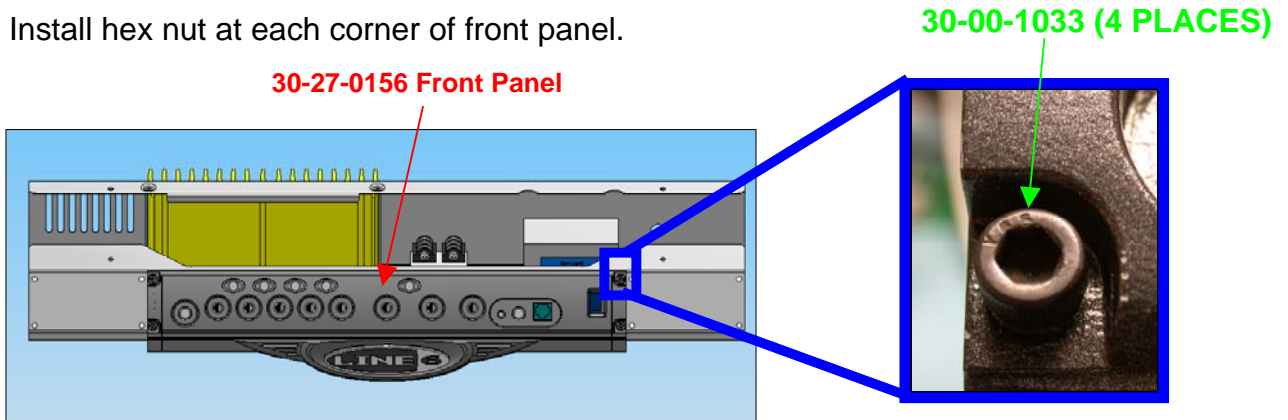

Chassis – Front View

STEP 22: Install plastic front panel extensions (30-27-0131) onto chassis. Secure each extension with four 10-32 x 3/8" screws (30-00-1033). Torque 3-4 in/lbs.

Install hex nut at each corner of front panel.

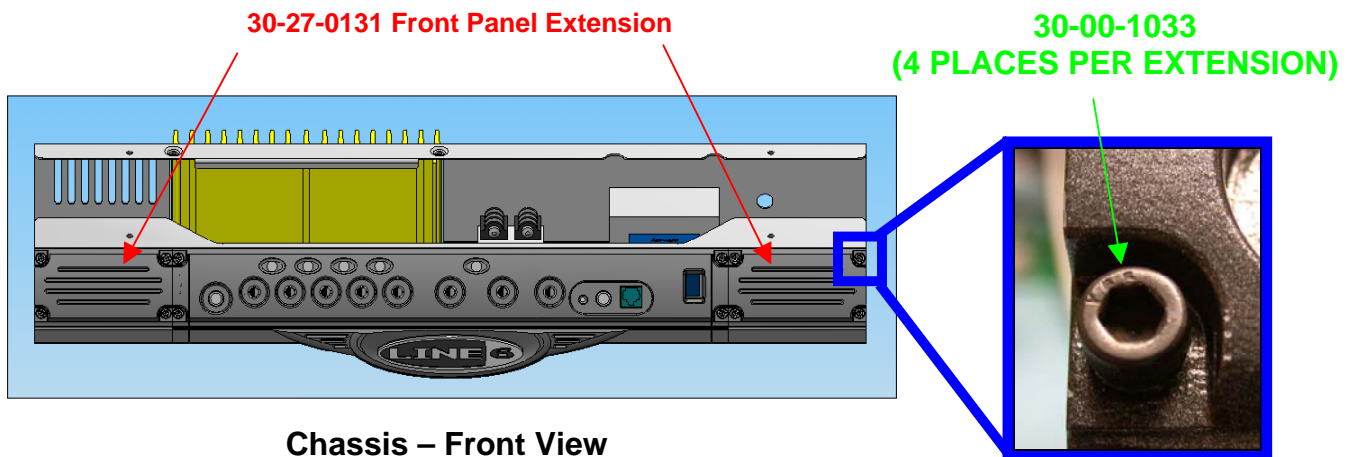

Chassis – Front View

STEP 23: Install plastic hex nuts (21-00-6616) on Guitar and Phone jacks. Hex nuts are purchased with the jacks and use a common part number. Torque 4-5 in/lbs.

Chassis – Front View

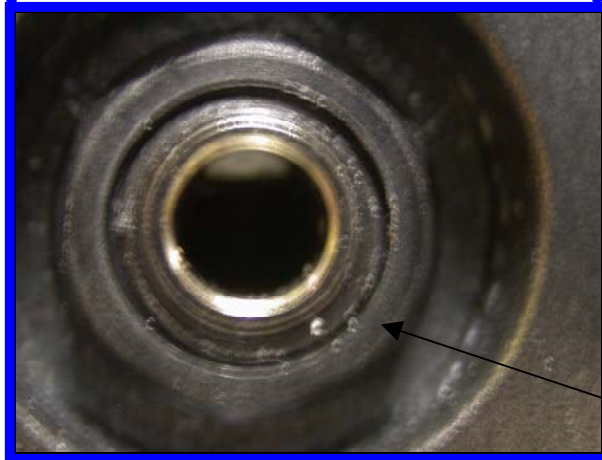
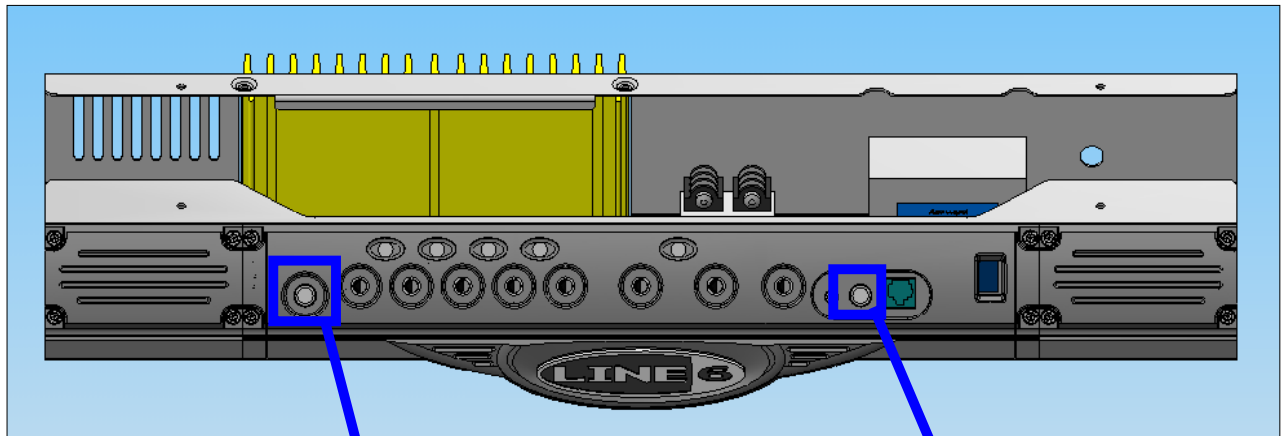

**21-00-6616
(2 PLACES)**

STEP 24: Install hex nut and washer on all eight potentiometers. The hex nuts and washers are purchased with the pots and have a common part number (01-48-0001). Install washers between front panel and hex nut. Washer not shown in view below. Torque 3-4 in/lbs.



STEP 25: Tighten screw for Main PCBA to chassis PEM stud. Apply Loctite P/N 21463 (Threadlocker 222) or equivalent, to secure screw to PCBA.

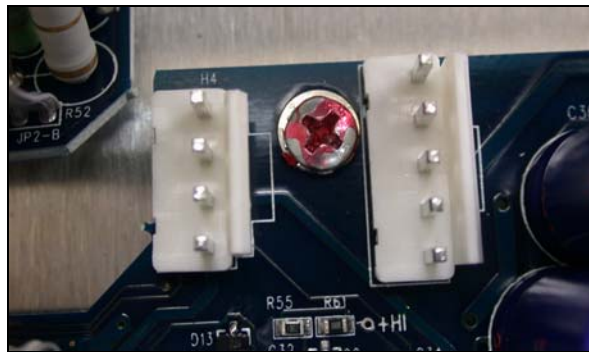

STEP 26: Connect ribbon cable (H1) on Main PCBA to header (H6) on Switch PCBA. Apply RTV to cable connector and header to insure cable never comes loose.

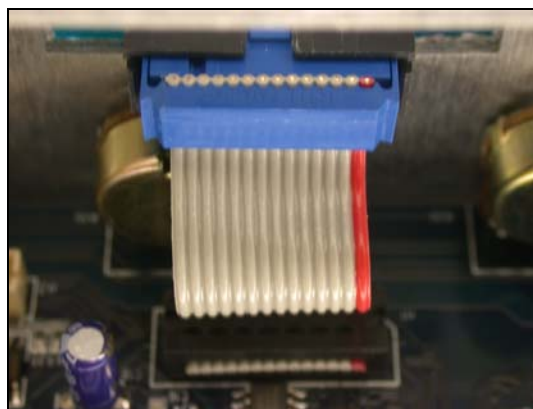

STEP 27: Install plastic chrome knobs (30-45-0011) on all eight potentiometer shafts.



STEP 28: Install assembled chassis and front panel into head enclosure per L6D000033.

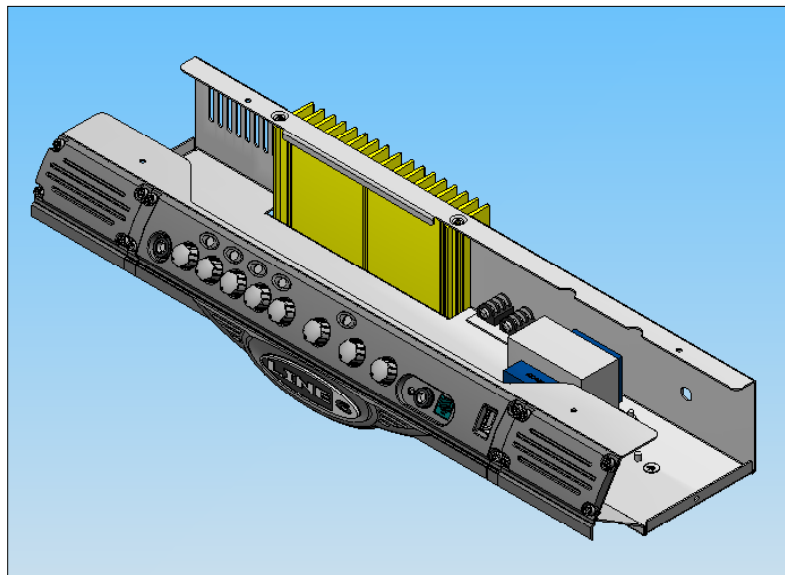

Completed Chassis Sub-Assy (Reference)



Spider II HD75 Final Assembly Instructions

Head Enclosure

Rev A

05-02-17

L6D000033

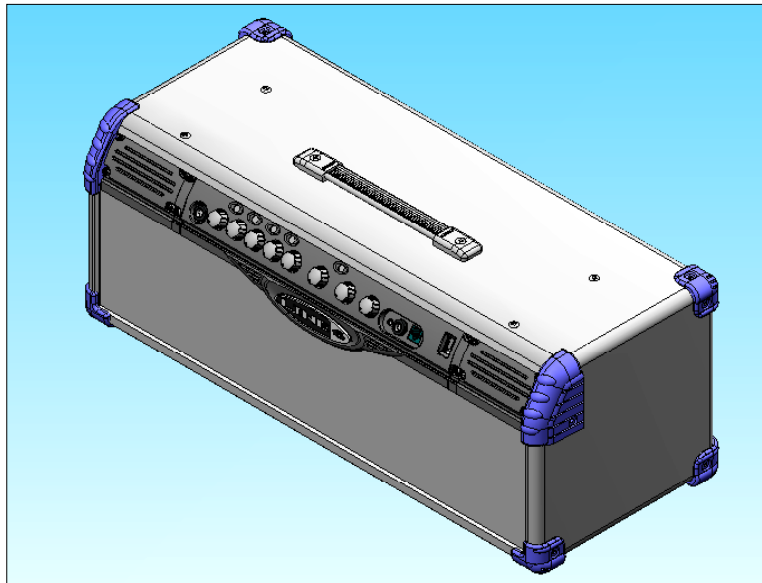

Forward and Notes

The information in this booklet applies to the mechanical assembly of the Spider II HD75 Head. It is suggested that the steps for assembly follow the order presented in these instructions.

A note on the text: the illustrations in this book are for reference only. In some cases, color and geometry of illustrations may not accurately reflect the color or exact geometry of actual parts.

- Unless otherwise noted, all dimensions are in inches.
- Part identifying notes are in this format: Description (Part Number)
- Drawings are not to scale.
- Torque value tolerance +/- .5 in.-lbs. Do not over tighten any components.

For clarity, not all component details are shown. This is especially true with respect to cable assemblies. They are often omitted from views to provide a clearer picture of the material discussed. Do not be confused by the absence (or unexpected presence) of any component in the illustrations in this book.

Step 1: Remove Cabinet Front Panel from cabinet.

The Cabinet Front Panel shall be removed prior to mounting chassis assembly into cabinet. Remove the three screws and finishing washers (one screw and one finishing washer on each side, and one screw and one finishing washer on the bottom) and slide front panel up and out of the cabinet.

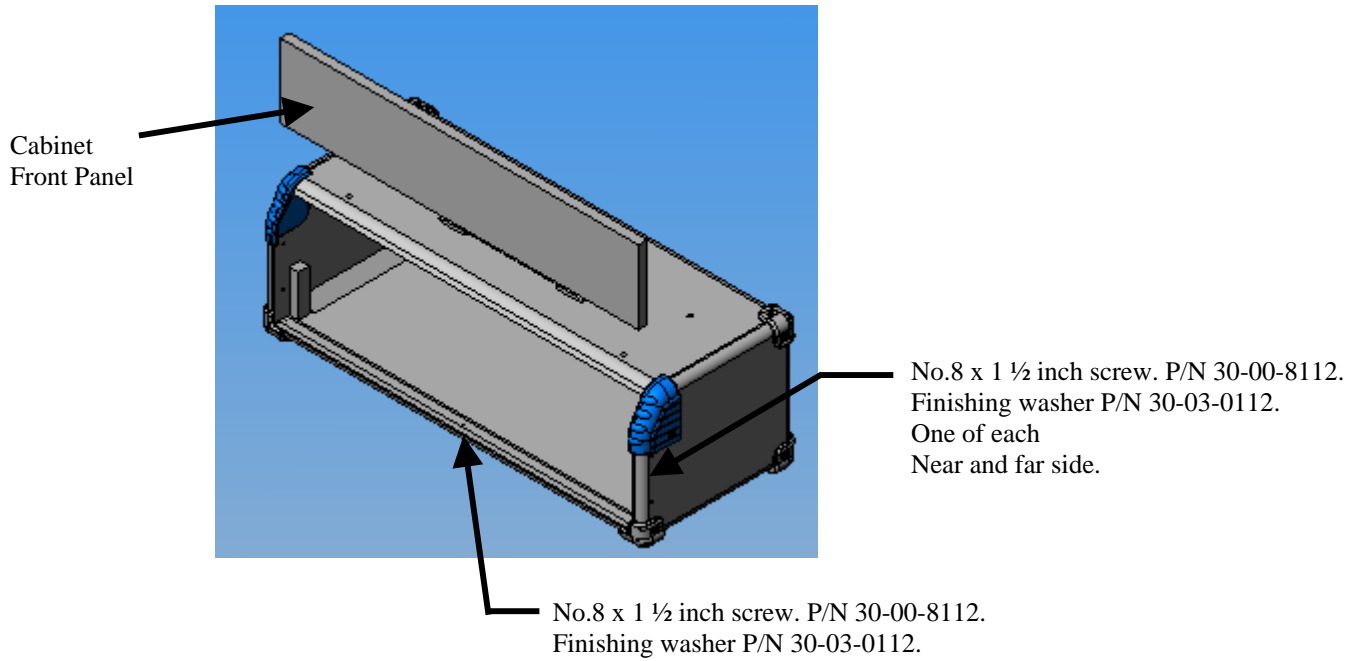
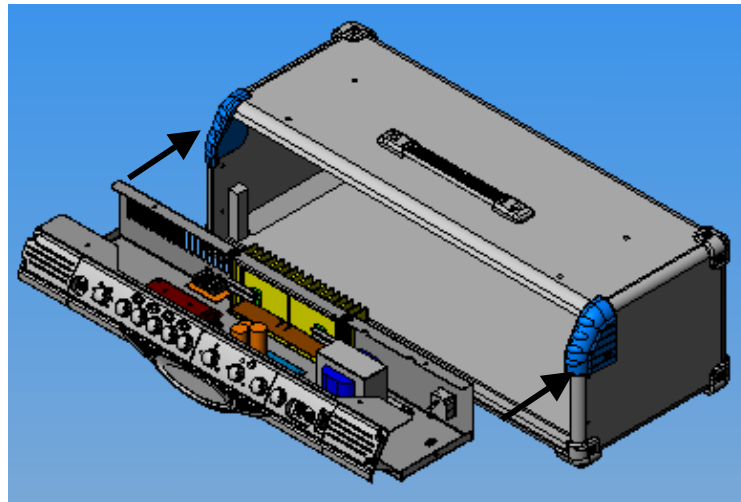
**Step 2:** Insert the chassis assembly into the cabinet from the front as shown.

Step 2 continued: Mount chassis assembly onto cabinet using four 10-32 UNC x 1 3/4 inch screws (part number 30-00-1128) and four finishing washers (part number 30-03-0112).

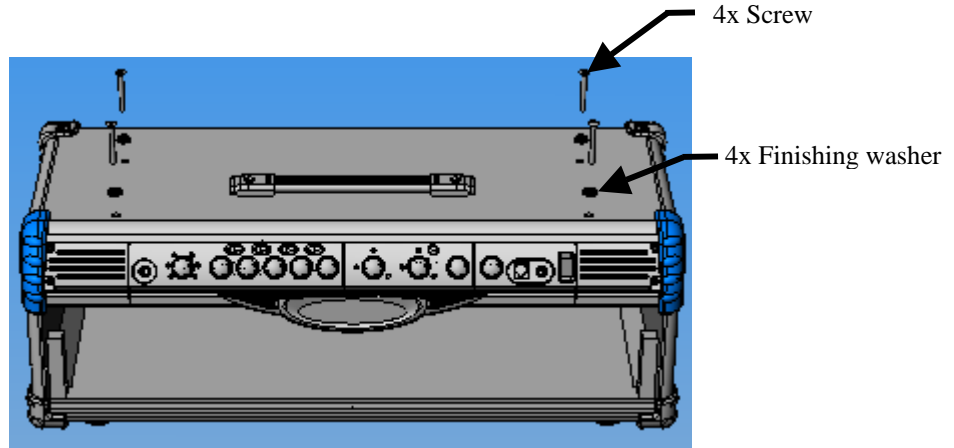

Step 3: Re-install Cabinet Front Panel.

Slide Cabinet Front Panel on the cabinet and behind plastic front panel that is mounted on the chassis assembly. Ensure that front panel is mounted into the dado groove on the bottom of the cabinet.

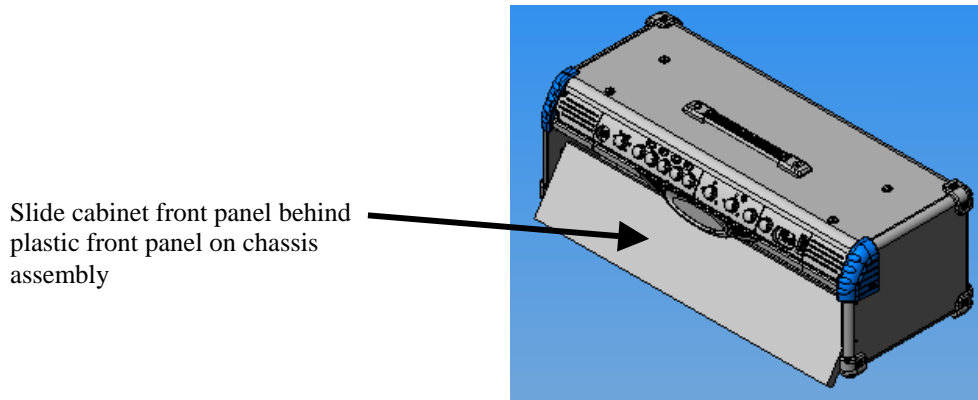
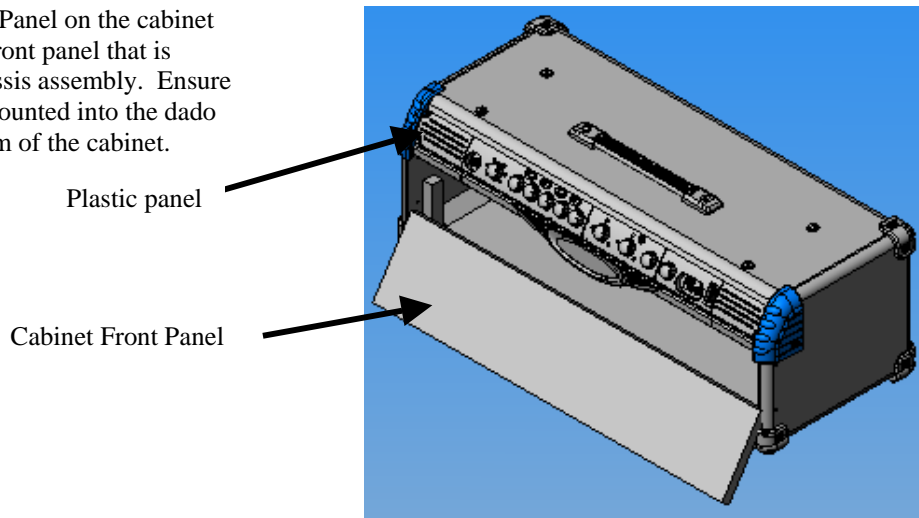

Step 3 continued: Secure Cabinet Front Panel in place by re-installing the three screws and finishing washers removed previously in step 1. Ensure that cabinet front panel is mounted into the dado groove on the bottom of the cabinet. Install bottom screw and finishing washer first, so that the cabinet front panel is pulled down into the bottom dado groove, and to help align the two side holes on each side of cabinet.

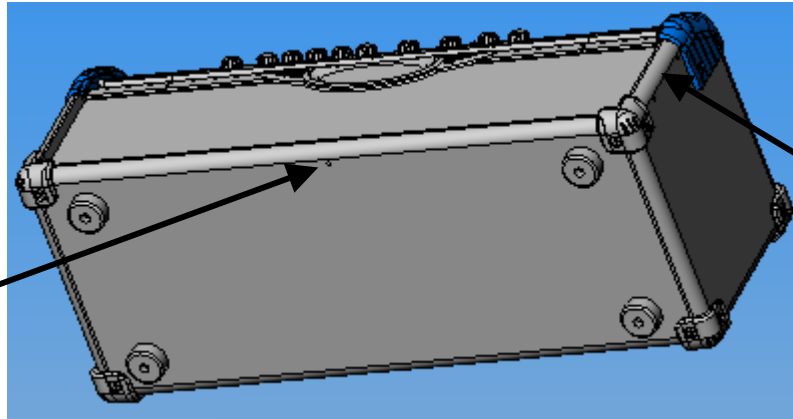

Bottom screw and finishing washer. Install first.

Side holes.
2 on each side.

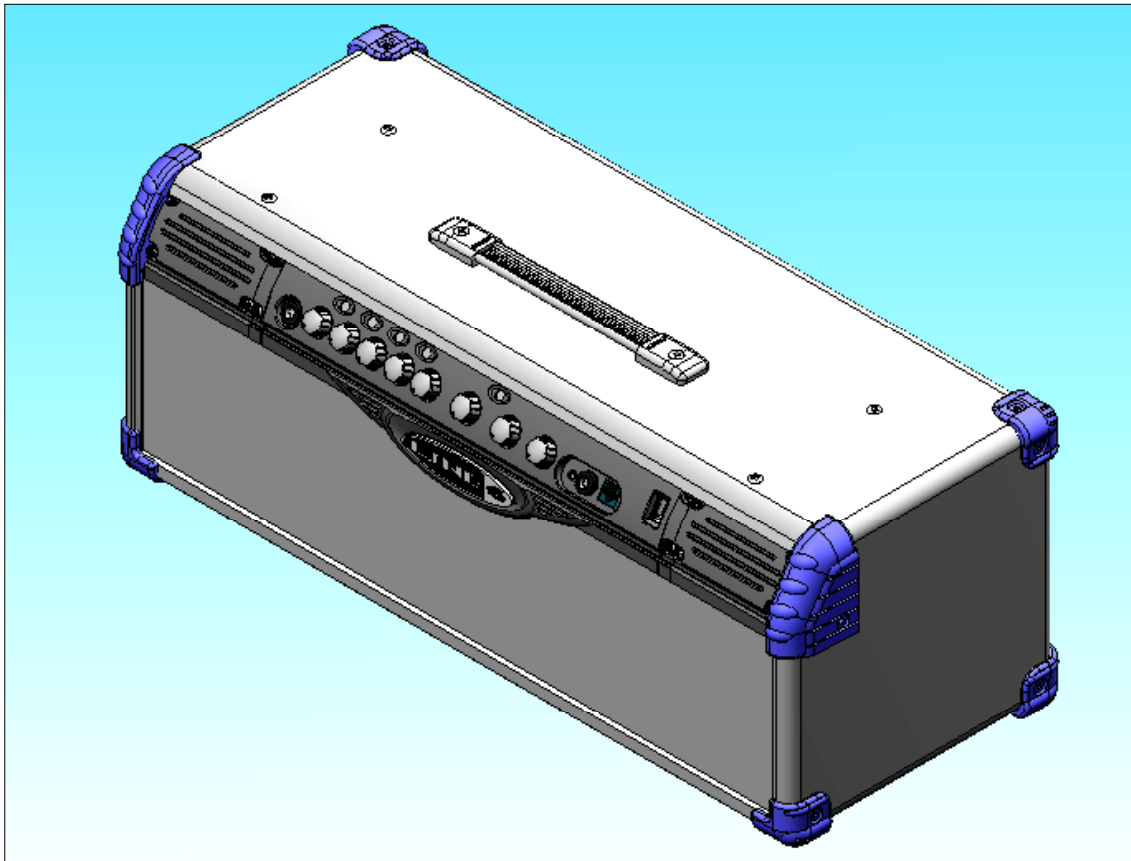

LINE 6

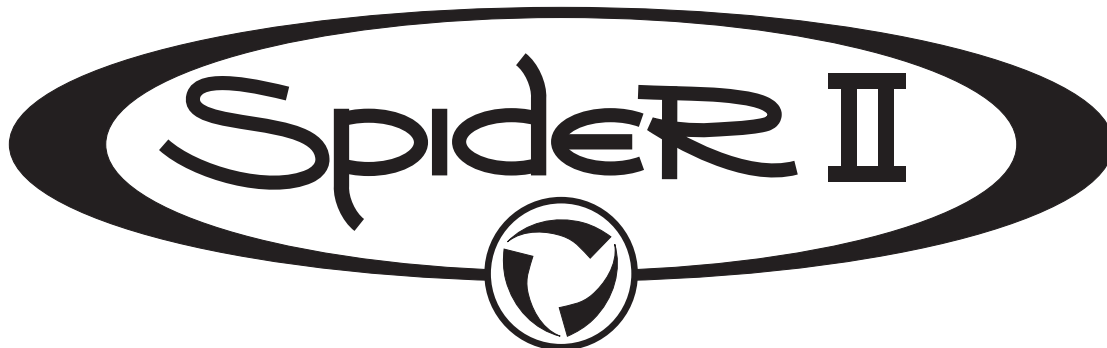

Pilot's Guide for Spider II 15, 30 & HD75
Manuel de pilotage pour le Spider II 15, 30 & HD75
Spider II 15, 30 & HD75 Pilotenhandbuch
Pilotenhandboek voor de Spider II 15, 30 & HD75

All product names referred to in this manual are trademarks of their respective owners, which are in no way associated or affiliated with Line 6. These trademarks of other manufacturers are used solely to identify the products of those manufacturers whose tones and sounds were studied during Line 6's sound model development.

Line 6, Spider II, FBV, FBV Shortboard, FBV4, FBV2, Floor Board, FB4 and Vetta are trademarks of Line 6, Inc. All other product names, trademarks, and artists' names are the property of their respective owners, which are in no way associated or affiliated with Line 6. Product names, images, song names and artists' names are used solely to identify the products whose tones and sounds were studied during Line 6's sound model development for this product. The use of these products, trademarks, images, and artists' names does not imply any cooperation or endorsement.

CAUTION: This equipment has been tested and found to comply with the limits for a Class B digital device pursuant to Part 15 of FCC Rules. Operation is subject to the following two conditions: (1) This device may not cause harmful interference, and (2) this device must accept any interference received, including interference that may cause undesired operation.

WARNING: To reduce the risk of fire or electric shock, do not expose this appliance to rain or moisture.



The exclamation point within a triangle means, "Caution!" Please read the information next to all caution signs.

CAUTION: To reduce the risk of fire or electric shock, do not remove screws. No user-serviceable parts inside. Refer servicing to qualified service personnel.



The lightning symbol within a triangle means, "Electrical caution!" It indicates the presence of information about operating voltage and potential risks of electrical shock.



This symbol within a triangle means, "Caution! Hot surface!" It is shown in areas that may become too hot to touch when the device is in operation.



**You should read these Important Safety Instructions.
Keep these instructions in a safe place.**



Before using your Spider II, carefully read the applicable items of these operating instructions and the safety suggestions.

1. Obey all warnings on the amp and in the Spider II Manual.
2. Connect only to AC power outlets rated 100-120V or 200-240V 47-63Hz (depending on voltage range of the unit; refer to back panel).
3. Do not perform service operations beyond those described in the Spider II Manual. Service is required when the apparatus has been damaged in any way, such as:
 - power-supply cord or plug is damaged
 - liquid has been spilled or objects have fallen into the apparatus
 - the unit has been exposed to rain or moisture
 - the unit does not operate normally or changes in performance in a significant way
 - the unit is dropped or the enclosure is damaged.
4. The bottom of the metal chassis can get hot during operation. Do not touch during operation or shortly after.
5. Do not place near heat sources, such as radiators, heat registers, or appliances which produce heat. Keep the rear of the unit at least three inches from walls or other items that might block heat radiation.
6. Do not block any of the ventilation openings or use in an enclosed space.
7. Guard against objects or liquids entering the enclosure. Do not use or place unit near water.
8. Do not step on power cords. Do not place items on top of power cords so that they are pinched or leaned on. Pay particular attention to the cord at the plug end and the point where it connects to the amp.
9. Unplug the amp when not in use for extended periods of time. Unplug the amp during lightning storms.
10. Clean only with a damp cloth.
11. Do not defeat the safety purpose of the grounding type plug. A grounding type plug has two blades and a third grounding prong. The third prong is provided for your safety. When the provided plug does not fit into your outlet, consult an electrician for replacement of the obsolete outlet.
12. Only use attachments/accessories specified by the manufacturer.
13. Prolonged listening at high volume levels may cause irreparable hearing loss and/or damage. Always be sure to practice “safe listening.”

1 Plug In Here

2 Channel Memories / Amp Models

The four channels each use a different Amp Model, and all come pre-loaded with a factory preset dialed in to nail a great tone. Press one of these buttons to hear the presets. To replace any preset with your own “snapshot” of all tone and effect knob positions (except Master Volume), press and hold one of these four buttons for two seconds. The light flashes when the save is complete.

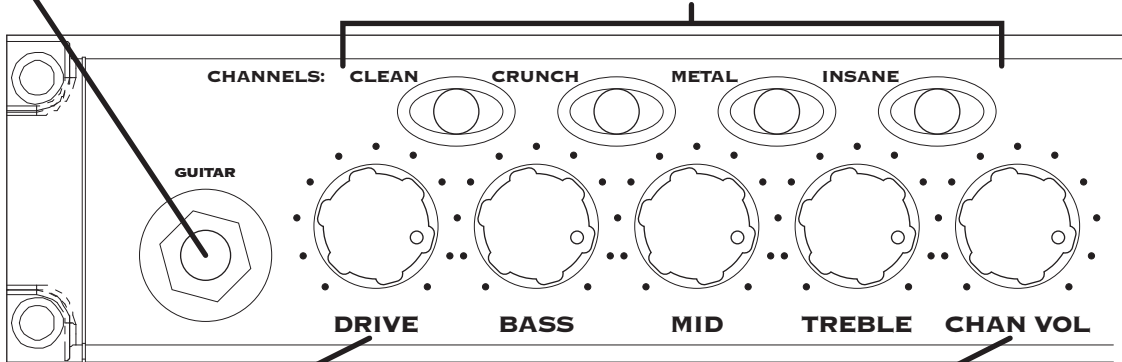

3 Tone Controls

Drive is like the volume or gain knob on other amps; controls how much “dirt” you get in your sound. Bass, Mid, and Treble controls are customized for each Channel to give you optimal tonal control.

4 Channel Volume

This control helps you balance the volumes of the amp-and-effect setups that you store in your Spider II’s channels. See (2) above for the low-down on channels.

6**Tap Delay Time**

Tap the Tap Delay Time button at least two times to set the delay time when either Tape Echo or Sweep Echo is active. The light will be lit solid when Reverb is active, and will be off when no echo or reverb effect is active. (Also see "Tap Button Extra Functions").

9**Headphone/Record Out**

Listen with headphones, or use this as a direct out for recording! (*The speaker is muted when this jack is in use.*)

10**FBV Pedal (not on Spider II 15)**

See "Footwork" section below for details.

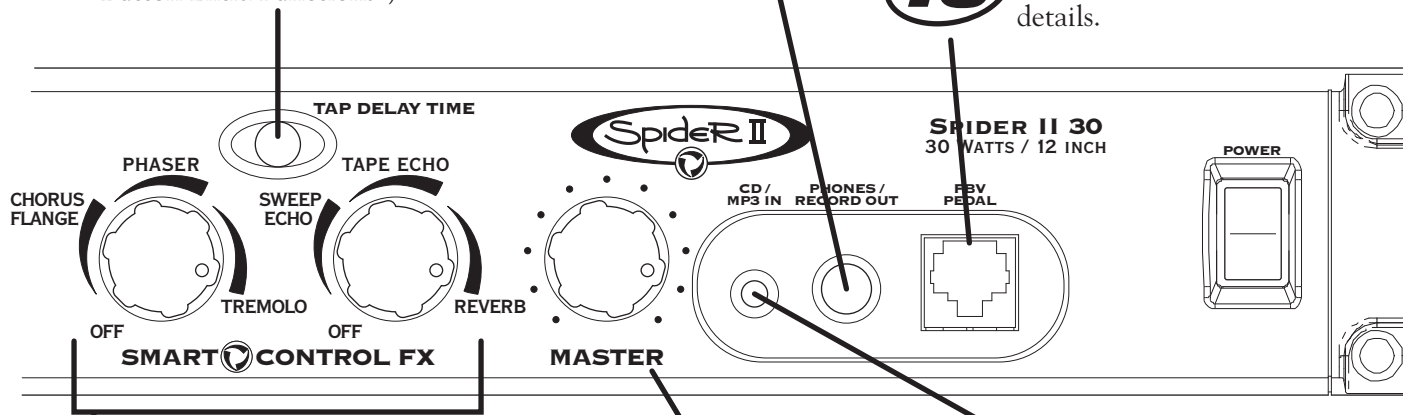
**5****Smart Control FX**

Spin one of these knobs to get great FX, fast and easy:

The first knob picks chorus/flange, phaser or tremolo, with a range of settings—from subtle to overpowering—for each effect.

The second knob picks tape echo, sweep echo or reverb with a range of mix settings from low to high. When you select an echo effect the Tap Delay Time light flashes the delay time; tap it to change the time.

7**Master Volume**

You can choose the overall volume of the amplifier, without affecting your tone.

8**CD/MP3 In**

Listen and play along with CD or MP3 tracks by connecting to this 1/8-inch input.

Welcome The Spider II...

Thank you for inviting Spider II home with you. This amp mines the tonal heritage of the past forty years of guitar amplifier design and matches it up with the kind of digital signal processing magic that will still be ahead of its time ten years from now.

Each of the four programmable channels is built on a different Amp Model with its own unique tone:

Clean

Select this Amp Model and adjust the tone controls to get crisp, amazing clean tones, great warm jazz tones, and all the high-end shimmer you'll need with a generous amount of bottom end to boot. Then dial up a little chorus and delay to get the ultimate clean sound!

Crunch

Plexi On Fire! This Amp Model is based on a '68 Marshall Plexi 100 watt with a few added extras; The combination of a Variac and the jumpered input channels creates that infamous brown sound that will feel like flames are shooting out the input jack! "Come on Dave... Give me a break!"

Metal

This Amp Model is based on the Mesa Dual Rectifier. For Spider II, we made careful enhancements to this classic tone. The resulting Amp Model has a definite modern flavor. This monster truck of tone delivers a tight bottom end that's big, powerful, tight and fast. Use this Amp Model to get a tight and punchy, high gain Metal sound.

Insane

Our goal with Insane was to provide you with as much input gain distortion as possible short of complete meltdown. You get an obscene helping of distortion, while still retaining tonal definition and character. As a result, you get way more bottom end and cabinet character than other small amps. Crank up the Drive control and prepare to dominate!

Tap Button Extra Functions

The Tap Delay Time button, in addition to setting the time of your echo effects, also lets you access a Distortion Boost and a built-in Noise Gate.

Distortion Boost

Press and hold the Tap Delay Time button as you turn the Drive knob up past twelve o'clock. As you do this, Spider II's CLEAN Channel light comes on to indicate that the Distortion Boost is on. This gives the kind of extra 'dirt' that you'd expect from a Distortion pedal with the distortion control set low and the output control set high. It boosts your guitar signal before it reaches the Amp Model, so that you hit the model harder and get a more distorted sound.

Noise Gate

Press and hold the Tap Delay Time button as you turn the echo/reverb FX knob up past twelve o'clock, and you'll turn on a built-in Noise Gate to help cut down on hiss and noise. As you do this, the INSANE Channel light comes on to indicate the Gate is on.

Special Hidden Functions

When you select an Amp Model, Spider II automatically sets its tone controls and effects to match that Amp Model. You can disable the auto-FX selection (but not tone control auto-selection) by powering up Spider II with the INSANE Channel button held. The auto-selection will be re-enabled next time you power up.

You can also reset your Spider II's programmable channels to their factory-programmed states by holding down the CLEAN Channel button as you turn on the power. **Warning:** This will erase ALL custom sounds you might have saved. Ask yourself, "Do I really want to do this?" If your answer is yes, then go for it!

Note for Spider II HD75 Users

The Spider II HD75's speaker outputs are set up for 4 ohm cabinets only. Cabinets of other impedances may cause the HD75 to overheat and shutdown to prevent damage.

Footwork (Spider II 30 & HD75 only)

Two optional foot controllers can be used with the Spider II 30 and HD75: the FBV Express for channel switching and delay time tap, or the FBV2 for channel scroll. Note that the FBV, FBV Shortboard, Floor Board and FB4 foot controllers will not work with Spider II 30 and HD75.

FBV foot controllers come with a RJ-45 cable. Connect it between the front panel of the Spider II and the side of the FBV. If you ever need a replacement cable, look for a Category 5 (or higher), “10 Base-T” or “RJ-45” cable with male connectors on both ends. These can be found at almost any computer supply retailer.

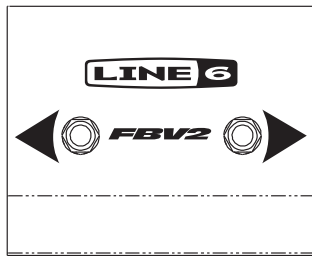

FBV2

The FBV2 functions as a two button channel scroll foot switch. Step on its switches to scroll through the four channels (Clean, Crunch, Metal, and Insane) of your Spider II 30 or HD75.

FBV Express

Step on a switch to choose from your Spider II's four channels. Want to change your Delay Time? Just tap the lit footswitch two or more times to the drummer's beat and presto—you're locked in! Press down the toe of the pedal to switch between wah and volume control.

NOTE: The tuner on the FBV Express is not supported by the Spider II 30 and HD75.

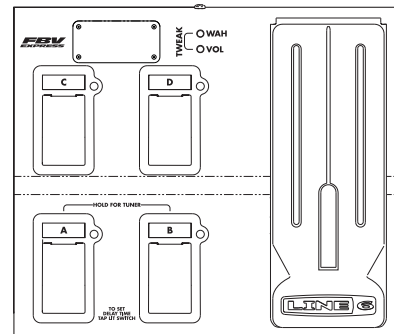

Pilot's Log

Get tone settings for a collection of great guitar songs from our web site, www.line6.com. Make a note of your favorite settings here by marking which channel is selected, the positions of the knobs, and the Tap Delay Time.

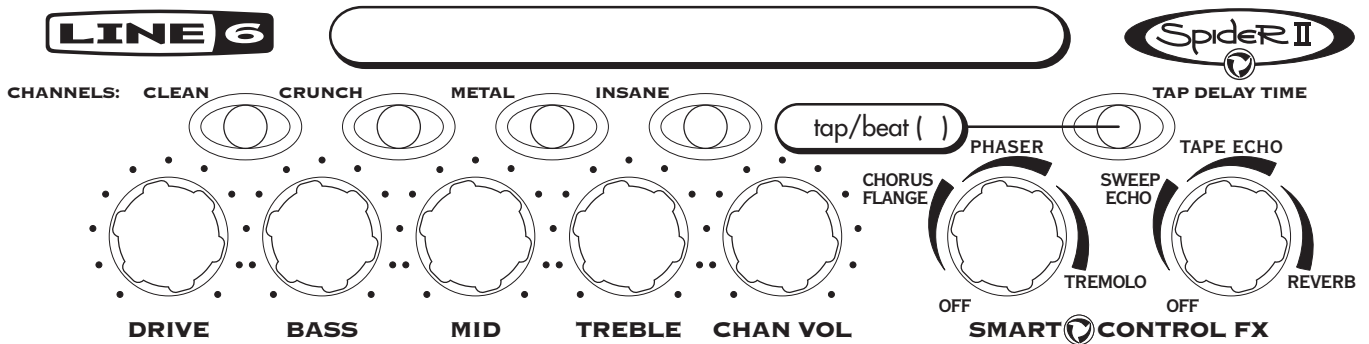
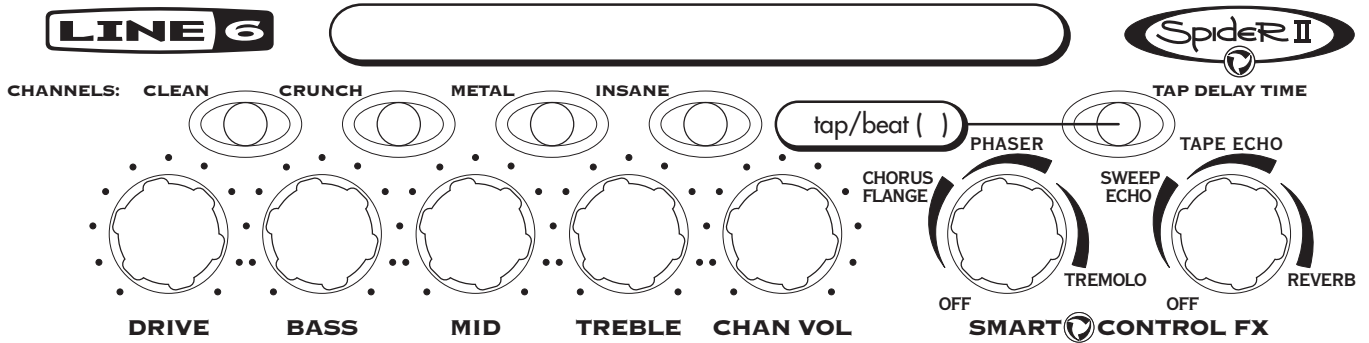

LINE 6



Spider II

CHANNELS: CLEAN

CRUNCH

METAL

INSANE

tap/beat ()

TAP DELAY TIME

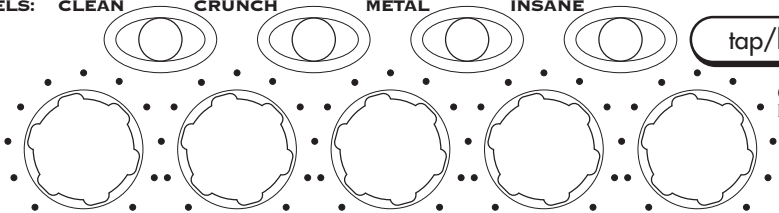

DRIVE

BASS

MID

TREBLE

CHAN VOL

CHORUS
FLANGE

PHASER

SWEEP
ECHO

TAPE ECHO

OFF

TREMOLO

OFF

REVERB

SMART CONTROL FX

LINE 6



Spider II

CHANNELS: CLEAN

CRUNCH

METAL

INSANE

tap/beat ()

TAP DELAY TIME

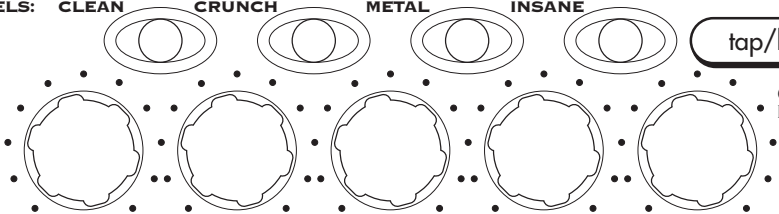

DRIVE

BASS

MID

TREBLE

CHAN VOL

CHORUS
FLANGE

PHASER

SWEEP
ECHO

TAPE ECHO

OFF

TREMOLO

OFF

REVERB

SMART CONTROL FX

LINE 6



CHANNELS: CLEAN

CRUNCH

METAL

INSANE

tap/beat ()

TAP DELAY TIME

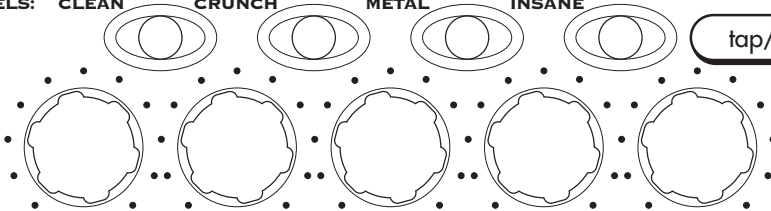

DRIVE

BASS

MID

TREBLE

CHAN VOL

CHORUS
FLANGE

PHASER

SWEEP
ECHO

TAPE ECHO

OFF

TREMOLO

OFF

REVERB

SMART CONTROL FX

LINE 6



CHANNELS: CLEAN

CRUNCH

METAL

INSANE

tap/beat ()

TAP DELAY TIME

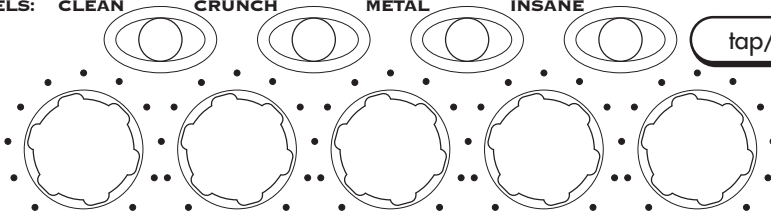

DRIVE

BASS

MID

TREBLE

CHAN VOL

CHORUS
FLANGE

PHASER

SWEEP
ECHO

TAPE ECHO

OFF

TREMOLO

OFF

REVERB

SMART CONTROL FX

LINE 6



Spider II

CHANNELS: CLEAN

CRUNCH

METAL

INSANE

tap/beat ()

TAP DELAY TIME

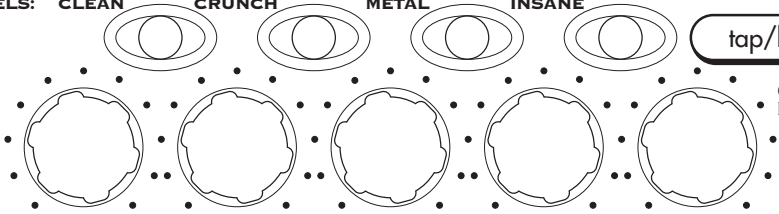

DRIVE

BASS

MID

TREBLE

CHAN VOL

CHORUS
FLANGE

PHASER

SWEEP
ECHO

TAPE ECHO

OFF

TREMOLO

OFF

REVERB

SMART CONTROL FX

LINE 6



Spider II

CHANNELS: CLEAN

CRUNCH

METAL

INSANE

tap/beat ()

TAP DELAY TIME

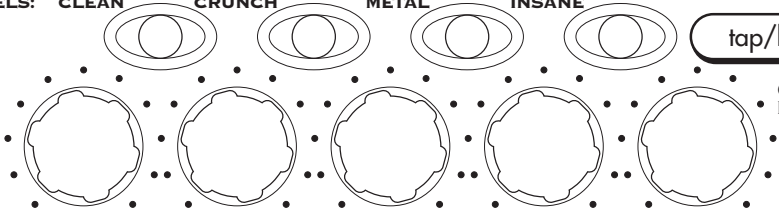

DRIVE

BASS

MID

TREBLE

CHAN VOL

CHORUS
FLANGE

PHASER

SWEEP
ECHO

TAPE ECHO

OFF

TREMOLO

OFF

REVERB

SMART CONTROL FX

LINE 6



CHANNELS: CLEAN

CRUNCH

METAL

INSANE

tap/beat ()

TAP DELAY TIME

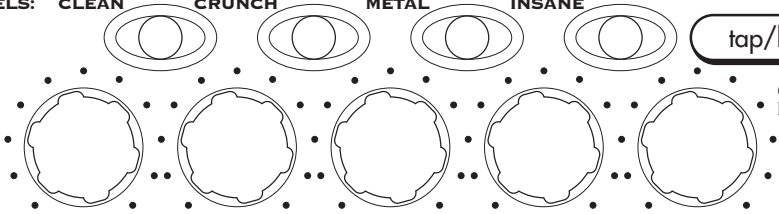

DRIVE

BASS

MID

TREBLE

CHAN VOL

CHORUS
FLANGE

PHASER

SWEEP
ECHO

TAPE ECHO

OFF

TREMOLO

OFF

REVERB

SMART CONTROL FX

LINE 6



CHANNELS: CLEAN

CRUNCH

METAL

INSANE

tap/beat ()

TAP DELAY TIME

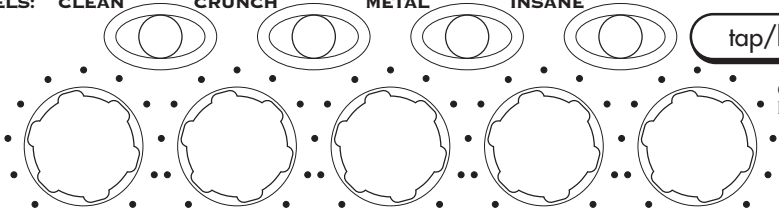

DRIVE

BASS

MID

TREBLE

CHAN VOL

CHORUS
FLANGE

PHASER

SWEEP
ECHO

TAPE ECHO

OFF

TREMOLO

OFF

REVERB

SMART CONTROL FX

Line 6, Spider II, FBV, FBV Shortboard, FBV4, FBV2, Floor Board, FB4 et Vetta sont des marques commerciales de Line 6, Inc. Tous les autres noms de produits, marques déposées et noms d'artistes sont la propriété de leurs détenteurs respectifs et ne sont nullement associés ou affiliés à Line 6. Ces noms, images et références aux artistes servent exclusivement à décrire certaines sonorités modélisées d'après les sons célèbres de ces produits ou artistes. L'utilisation de ces noms de produits, images, marques déposées et noms d'artistes n'implique aucune coopération ni sponsorship.

PRUDENCE: Ce produit a fait l'objet de tests et a été déclaré conforme aux normes des appareils numériques de classe B, conformément à la partie 15 des réglementations FCC. Le fonctionnement est soumis aux deux conditions suivantes: (1) Le produit ne peut pas causer d'interférences nocives et (2) il doit accepter toute interférence reçue, même des interférences susceptibles d'entraîner un fonctionnement indésirable.

AVERTISSEMENT: Pour éviter tout risque d'incendie ou d'électrocution, n'exposez jamais ce produit à la pluie ni à l'humidité.



Le point d'exclamation dans un triangle signifie "Prudence". Lisez toujours les informations précédées de ce symbole.

PRUDENCE: Pour réduire les risques d'incendie et d'électrocution, ne desserrez jamais aucune vis. Ce produit ne contient aucune pièce pouvant être réparée par l'utilisateur. Confiez toute réparation à un technicien qualifié.



L'éclair dans un triangle représente "un avertissement électrique". Il attire votre attention sur des informations relatives à la tension de fonctionnement et aux risques d'électrocution.



Ce symbole inscrit dans un triangle signifie "Attention! Surface chaude!" Il est présent aux endroits susceptibles de chauffer fortement pendant l'utilisation et qu'il faut donc éviter de toucher.



**Lisez attentivement ces informations importantes liées à la sécurité.
Conservez ce manuel en lieu sûr pour toute référence ultérieure.**



Avant d'utiliser votre Spider II, lisez attentivement les consignes d'utilisation et de sécurité ci-dessous.

1. Respectez tous les avertissements imprimés sur l'ampli et dans le manuel du Spider II.
2. Branchez ce produit uniquement à une prise de courant de 100~120V ou de 200~240V, 47~63Hz (selon la tension d'utilisation du produit – voyez son panneau arrière).
3. N'effectuez aucune opération d'entretien autre que celles préconisées dans le manuel du Spider II. Faites réparer ce produit s'il a subi tout dommage, notamment:
 - si le cordon d'alimentation ou sa fiche est endommagé;
 - si du liquide ou des objets ont pénétré dans l'appareil;
 - si ce produit a été exposé à la pluie ou à de l'humidité;
 - si ce produit ne fonctionne pas normalement ou si ses performances baissent de manière significative;
 - si ce produit est tombé ou son boîtier est endommagé.
4. La partie inférieure du châssis métallique peut chauffer pendant l'utilisation. Ne touchez pas cette partie pendant ou peu après l'utilisation.
5. Ne placez jamais le produit à proximité de sources de chaleur comme des radiateurs, des poêles ou tout autre appareil produisant de la chaleur. Conservez un espace d'au moins 10cm entre le dos de ce produit et le mur ou tout autre objet susceptible de bloquer la chaleur se dégageant de l'appareil.
6. Ne bloquez aucun orifice de ventilation et n'utilisez pas l'appareil dans un espace fermé.
7. Veillez à ne jamais laisser d'objet ni de liquide pénétrer dans le boîtier de ce produit. Ne placez et n'utilisez jamais ce produit à proximité d'eau.
8. Ne marchez pas sur le cordon d'alimentation. Évitez de le coincer sous des objets lourds. Prenez particulièrement soin du cordon au niveau de la fiche secteur et du point de connexion à l'ampli.
9. Débranchez l'amplificateur du secteur si vous ne comptez pas l'utiliser pendant une période prolongée. Débranchez aussi l'amplificateur en cas d'orage.
10. Nettoyez ce produit avec un chiffon humide.
11. Ne modifiez jamais la mise à la terre prévue pour votre sécurité. Une fiche avec mise à la terre comporte un orifice pour la prise de terre en plus des deux broches. Cet orifice sert à assurer votre sécurité. Si la fiche du cordon fourni est incompatible avec vos prises de courant, faites-la remplacer par un électricien qualifié.
12. Utilisez uniquement les fixations/accessoires préconisés par le fabricant.
13. Une écoute prolongée à haut volume peut provoquer une perte d'audition et/ou des dommages irréversibles de l'ouïe. Consommez toujours le volume d'écoute avec modération.

1 Branchez votre guitare ici

2 Mémoires/modèles d'amplis
Chacune des quatre mémoires utilise un autre modèle d'ampli ainsi que les réglages qui, à notre sens, exploitent bien le son en question. Pour mémoriser un "cliché" personnel de tous les réglages des commandes (sauf MASTER), maintenez un de ces boutons enfoncé pendant au moins deux secondes. Ce faisant, vous remplacez le son d'usine en question. Une fois les réglages sauvegardés, le témoin clignote brièvement.

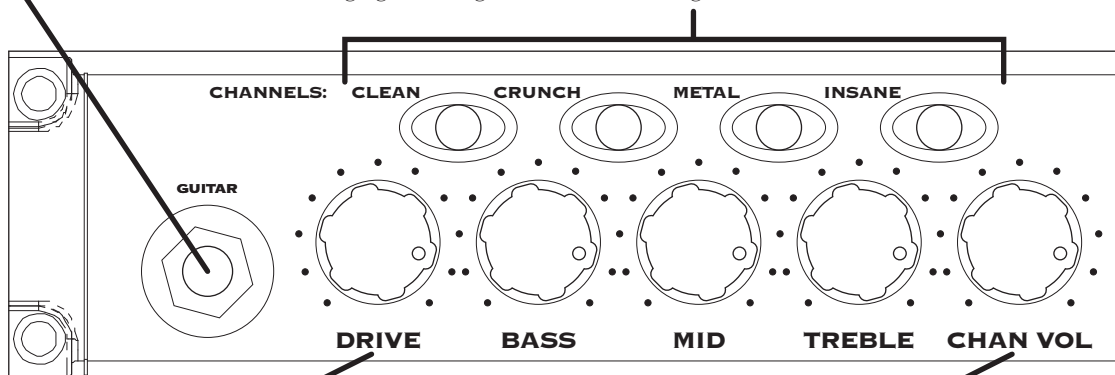

3 Commandes de tonalité
DRIVE correspond à la commande de volume ou de gain d'autres amplificateurs: servez-vous en pour régler le degré "d'encrassement" du son. Le comportement des commandes BASS, MID et TREBLE s'adapte au modèle d'amplificateur de la mémoire choisie.

4 Channel Vol
Cette commande permet de régler les sons d'amplis et effets mémorisés dans le Spider II approximativement au même volume. Voyez (2) pour en savoir plus sur les mémoires.

6 Temps de retard (Tap)

Appuyez plusieurs fois sur le bouton TAP DELAY TIME pour régler le temps de retard pour l'effet "Tape Echo" ou "Sweep Echo" (pour autant qu'il soit sélectionné). Le témoin reste allumé (cesse de clignoter) lorsque l'effet de réverb est actif et s'éteint lorsque vous n'utilisez ni de l'écho ni de la réverb. (Voyez aussi "Fonctions "bonus" du bouton TAP".)

9 Sortie casque/directe

Branchez-y un casque d'écoute ou utilisez cette prise comme sortie directe pour des enregistrements. (*Le haut-parleur interne est coupé lorsque vous branchez une fiche à cette prise.*)

10 Pédale FBV (pas sur le Spider II 15)

Voyez aussi "Pédaliers".

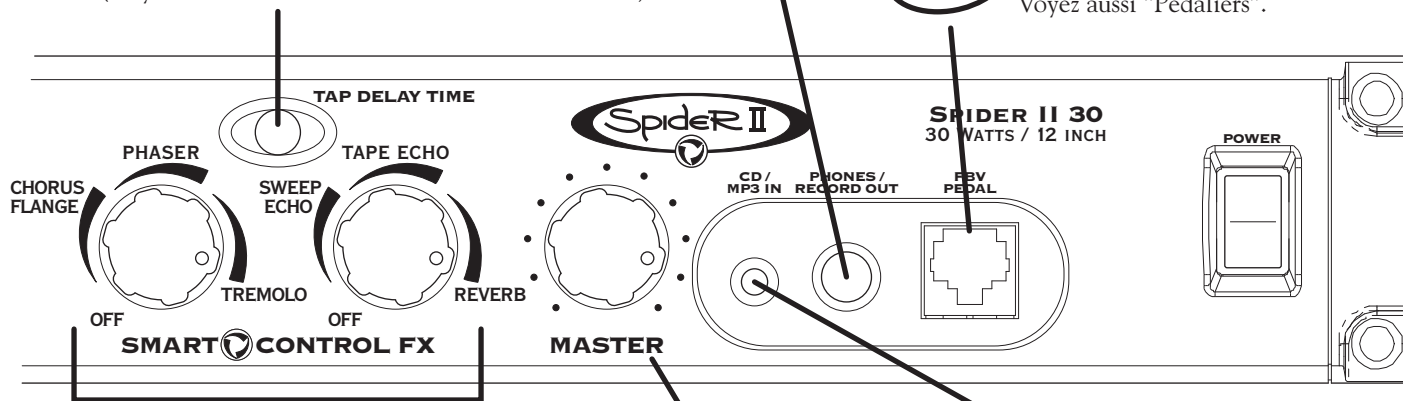

5

Smart Control FX

Ces commandes permettent de régler instantanément l'effet voulu: La première sert à choisir l'effet chorus/flanger, phaser ou tremolo. L'intensité s'échelonne pour chaque effet du "décent" au "renversant". La deuxième commande propose des effets delay, écho à bande, "Sweep Echo" et réverb. De plus, vous pouvez régler la balance entre l'effet et le signal original. Lorsque vous choisissez un effet d'écho, le témoin du bouton TAP clignote au rythme du temps de retard. Vous pouvez modifier ce dernier en appuyant plusieurs fois sur le bouton.

7

Master Volume

Le volume général n'a aucune influence sur votre son et peut donc être réglé en toute liberté.

8

Entrée CD/MP3

Branchez un lecteur de CD ou MP3 à cette prise 1/8" (mini-jack) pour pouvoir accompagner vos morceaux favoris.

Bienvenue au Spider II...

Nous vous remercions d'accueillir un Spider II chez vous. Cet amplificateur est, en quelque sorte, la synthèse experte des amplificateurs les plus prisés des 40 dernières années. Il allie à ce trésor des possibilités que seul le traitement de signal numérique peut offrir et qui seront toujours à la page dans 10 ans.

Chaque mémoire ("canal") repose sur un autre modèle d'ampli et se comporte donc différemment des autres.

Clean

Choisissez ce modèle et tournez les commandes d'égalisation pour produire des sons "clean" d'une clarté surprenante, notamment des sons jazz chaleureux, qui se distinguent par leur brillance et leur générosité dans les graves. Il ne vous reste plus qu'à ajouter une pincée de chorus et un soupçon de delay pour relever le tout!

Crunch

Un Plexi flambé! Ce modèle est basé sur un Marshall Plexi 100W de '68 et propose plusieurs atouts. La combinaison d'un Variac et du pontage des canaux d'entrée produit le fameux "Brown Sound", donnant l'impression que l'amplificateur crache des flammes! "Allez, Dave... Ne te fâche pas!"

Metal

Ce modèle est basé sur le Mesa Boogie Dual Rectifier. Le Spider II apporte quelques améliorations à ce son classique, ce qui lui confère une touche nettement plus moderne. Ce monstre sonore produit des graves puissants, "compacts" et pleins de pêche. C'est le modèle parfait pour obtenir un son de Metal cinglant.

Insane

Avec ce modèle, nous voulions augmenter le niveau à un point tel que la saturation frôle l'implosion de l'ampli. La distorsion est spectaculaire mais ne change rien à la définition ni au caractère du son. Par conséquent, les graves sont nettement plus puissants et ont plus de "grain d'enceinte" que sur d'autres petits amplis. Tournez la commande DRIVE et préparez-vous à conquérir le monde!

Fonctions “bonus” du bouton TAP

Le bouton TAP ne sert pas uniquement au réglage du temps de retard du delay. Il permet aussi de régler le booster de distorsion et le seuil du noise gate.

Booster de distorsion

Maintenez le bouton TAP enfoncé et réglez la commande DRIVE sur une valeur au-delà de la position “midi”. Le témoin de la mémoire CLEAN s’allume pour indiquer que le Spider II vient d’activer le booster. Le son est alors plus “crasseux” – un peu comme sur une pédale de distorsion dont on règle la distorsion sur une valeur modeste et le niveau de sortie sur une valeur élevée. Cette distorsion est produite avant le modèle d’amplificateur. Comme ce dernier reçoit un niveau plus élevé, la saturation sera d’autant plus intense.

Noise gate

Maintenez enfoncé le bouton TAP tout en réglant la commande FX ECHO/REVERB sur une valeur au-delà de “midi” pour activer le noise gate. Ce circuit réduit le bourdonnement et le bruit quand vous ne jouez pas. Quand le gate est actif, le témoin de la mémoire INSANE s’allume.

Fonctions spéciales cachées

Quand vous choisissez un modèle d’ampli, le Spider II règle automatiquement l’égalisation et les effets en fonction du choisi. Vous pouvez désactiver la sélection automatique des effets (mais pas les changements d’égalisation) en maintenant le bouton INSANE enfoncé et en mettant le Spider II sous tension. La sélection automatique des effets est toutefois réactivée à la prochaine mise sous tension.

En cas de besoin, vous pouvez rappeler les sons d’usine en maintenant le bouton CLEAN enfoncé tout en mettant le Spider II sous tension. **Avertissement:** Cette opération efface TOUS vos sons personnels. Demandez-vous donc “Est-ce vraiment ce que je voulais faire?” Si la réponse est affirmative, allez-y!

Remarque pour les utilisateurs du Spider II HD75

Les sorties de la tête Spider II HD75 sont exclusivement conçues pour des enceintes de 4Ω. Des enceintes d’autres impédances risquent d’entraîner une surchauffe et une coupure de la HD75 pour éviter tout dommage.

Pédaliers (Spider II 30 & HD75 uniquement)

Vous pouvez brancher l'un des deux pédaliers au Spider II 30 et à la HD75: un FBV Express pour changer de mémoire et "taper" le temps de retard (Delay) ou un FBV2 pour parcourir les mémoires. Notez toutefois que les pédaliers FBV, FBV Shortboard, Floor Board et FB4 ne fonctionnent pas avec le Spider II 30 et la HD75.

Les pédaliers FBV sont livrés avec un câble RJ-45. Branchez ce câble en face avant du Spider II et à la prise latérale du FBV. Si vous devez remplacer le câble, choisissez un câble de Catégorie 5 (ou plus), "10 Base-T" ou "RJ-45", doté de fiches mâles des deux côtés. Vous trouverez ces câbles chez pratiquement tous les revendeurs de matériel informatique.

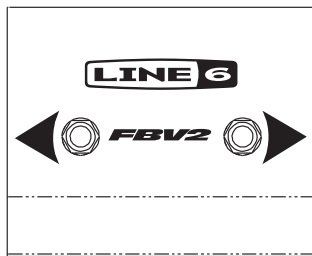

FBV2

Les deux boutons du commutateur au pied FBV2 servent à parcourir les mémoires. Appuyez sur ces commutateurs pour sélectionner tour à tour les quatre mémoires (Clean, Crunch, Metal et Insane) de votre Spider II 30 ou HD75.

FBV Express

Appuyez sur un commutateur pour sélectionner une des quatre mémoires du Spider II. Vous voulez changer le temps de retard (Delay)? "Tapez" simplement deux fois sur le commutateur allumé (de la mémoire sélectionnée) en suivant le rythme de votre batteur – et le tour est joué! Enfoncez le côté "orteils" de la pédale pour alterner entre le contrôle du wah et du volume.

REMARQUE: L'accordeur du FBV Express n'est pas compatible avec le Spider II 30 et la HD75.

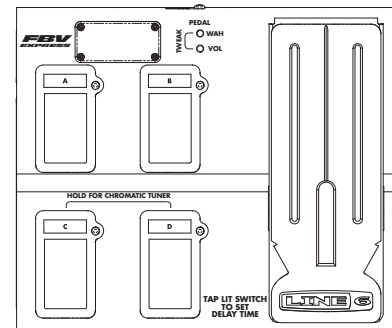

Album de vos meilleurs sons

Sachez que notre site, www.line6.com, regorge d'idées pour de nouvelles sonorités couvrant un large éventail de styles musicaux. D'autre part, vous pouvez immortaliser vos propres créations en indiquant les positions des commandes et en notant la valeur Tap dans les illustrations suivantes.

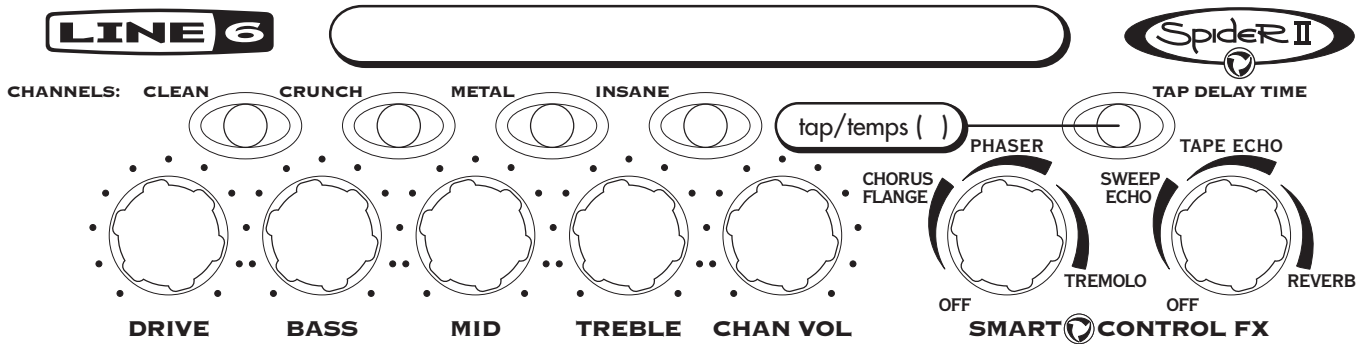
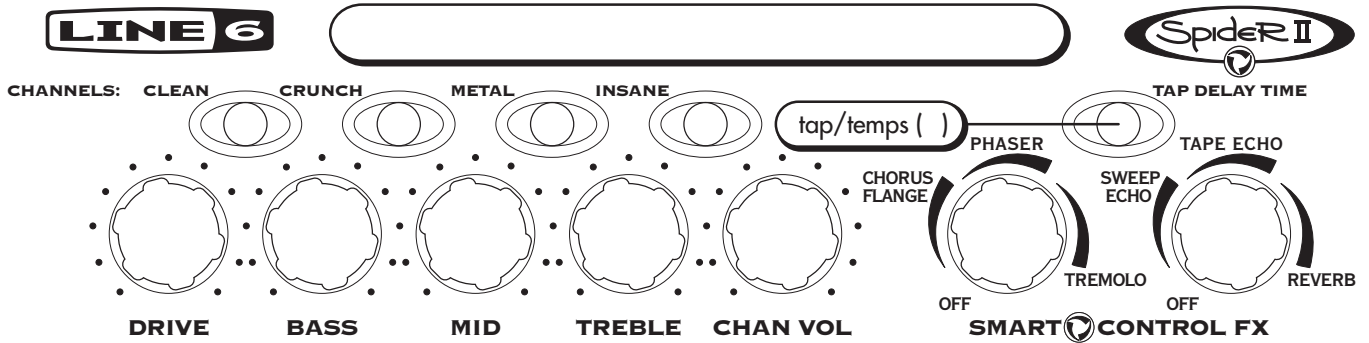

LINE 6



CHANNELS: CLEAN

CRUNCH

METAL

INSANE

tap/temps ()

TAP DELAY TIME

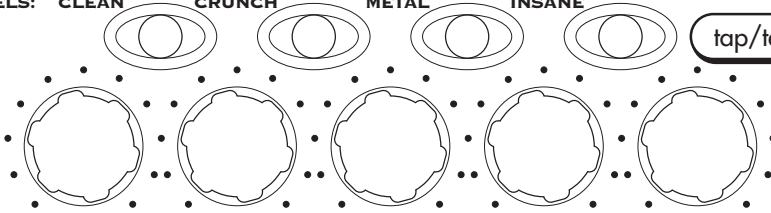

DRIVE

BASS

MID

TREBLE

CHAN VOL

CHORUS
FLANGE

PHASER

SWEEP
ECHO

TAPE ECHO

OFF

TREMOLO

OFF

REVERB

SMART CONTROL FX

LINE 6



CHANNELS: CLEAN

CRUNCH

METAL

INSANE

tap/temps ()

TAP DELAY TIME

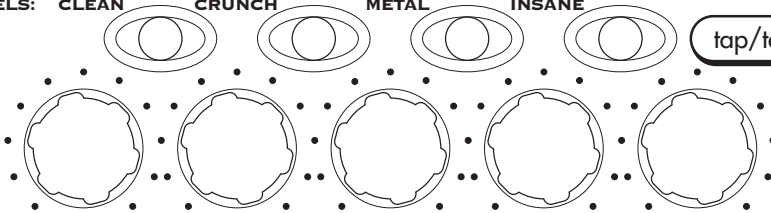

DRIVE

BASS

MID

TREBLE

CHAN VOL

CHORUS
FLANGE

PHASER

SWEEP
ECHO

TAPE ECHO

OFF

TREMOLO

OFF

REVERB

SMART CONTROL FX

LINE 6



CHANNELS: CLEAN

CRUNCH

METAL

INSANE

tap/temps ()

TAP DELAY TIME

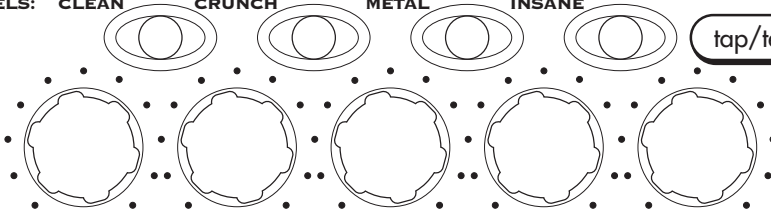

DRIVE

BASS

MID

TREBLE

CHAN VOL

CHORUS
FLANGE

PHASER

SWEEP
ECHO

TAPE ECHO

OFF

TREMOLO

OFF

REVERB

SMART CONTROL FX

LINE 6



CHANNELS: CLEAN

CRUNCH

METAL

INSANE

tap/temps ()

TAP DELAY TIME

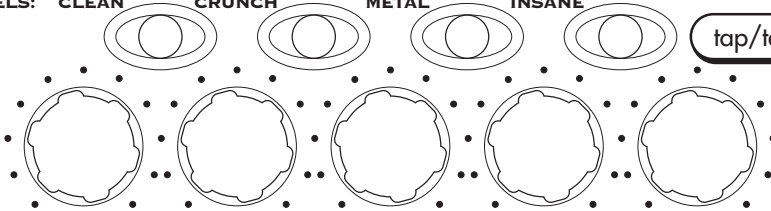

DRIVE

BASS

MID

TREBLE

CHAN VOL

CHORUS
FLANGE

PHASER

SWEEP
ECHO

TAPE ECHO

OFF

TREMOLO

OFF

REVERB

SMART CONTROL FX

Line 6, Spider II, FBV, FBV Shortboard, FBV4, FBV2, Floor Board, FB4 und Vetta sind Warenzeichen der Line 6, Inc. Alle erwähnten Produktnamen, Warenzeichen und Künstlernamen sind Eigentum der betreffenden Hersteller oder Rechtspersonen, die in keiner Weise mit Line 6 verbunden sind. Diese Namen und Bezeichnungen werden nur zur Veranschaulichung bestimmter Modelle verwendet, damit man weiß, welches Gerät oder welcher Künstler dafür Pate gestanden hat. Die Erwähnung dieser Produkt- und Künstlernamen bzw. Warenzeichen weist nicht auf eine Zusammenarbeit oder gar Empfehlung der jeweiligen Eigentümer hin.

VORSICHT: Dieses Produkt entspricht den Grenzwerten von "Part 15" der FCC-Bestimmungen für Digital-Geräte der Klasse B. Die Bedienung unterliegt folgenden beiden Bedingungen: (1) Das Gerät darf keine schädlichen Interferenzen verursachen; (2) es muss alle empfangenen Interferenzen akzeptieren, darunter auch Interferenzen, die Funktionsstörungen verursachen könnten.

WARNUNG: Um Brand- und Stromschlaggefahr zu vermeiden, dieses Produkt niemals Regen oder Feuchtigkeit aussetzen.



Das Ausrufezeichen in einem Dreieck bedeutet "Vorsicht!" Lies dir alle Informationen neben solchen Symbolen sorgfältig durch.

VORSICHT: Um Brand- und Stromschlaggefahr zu vermeiden, niemals die Schrauben entfernen. Das Produkt niemals selbst warten. Überlasse das einem qualifizierten Wartungstechniker.



Der Blitz in einem Dreieck stellt eine "elektrische Warnung" bezüglich der benötigten Stromspannung bzw. einer denkbaren Stromschlaggefahr dar.



Dieses Symbol in einem Warndreieck verweist auf eine heiße Oberfläche. Solche Symbole finden sich an und auf Komponenten, die man während des Betriebs nicht berühren darf.



**Bitte die folgenden wichtigen Sicherheitshinweise durchlesen.
Bewahre diese Anleitung an einem sicheren Ort auf.**



Vor dem Einsatz des Spider II musst du dir alle zutreffenden Punkte und Sicherheitshinweise durchlesen.

1. Beachte alle auf dem Spider II selbst und im Pilotenhandbuch aufgeführten Warnungen.
2. Verbinde das Gerät nur mit einer 100~120V- bzw. 200~240V/47~63Hz-Steckdose (je nachdem, welche Spannung dein Modell benötigt; siehe das Typenschild auf der Rückseite).
3. Führe nur die im Spider II-Pilotenhandbuch erwähnten Bedienvorgänge aus. In folgenden Fällen muss das Produkt zur Reparatur eingereicht werden:
 - wenn das Netzkabel oder der Stecker beschädigt ist
 - wenn Flüssigkeiten oder Fremdkörper in das Geräteinnere gelangt sind
 - wenn das Produkt Regen oder Feuchtigkeit ausgesetzt war
 - wenn sich das Produkt abnormal oder nicht mehr in vollem Umfang erwartungsgemäß verhält
 - wenn das Produkt hingefallen ist und das Gehäuse Schäden aufweist
4. Die Unterseite des Metallchassis' wird während des Betriebs heiß. Berühre es niemals, solange das Gerät eingeschaltet ist bzw. unmittelbar danach.
5. Stelle das Produkt niemals in die Nähe von Wärmequellen, z.B. Heizkörpern, Öfen oder anderen Geräten, die starke Hitze erzeugen. Zwischen der Rückseite des Gerätes und einer Wand bzw. anderen Gegenständen, welche die Lüftung beeinträchtigen könnten, muss ein Freiraum von mindestens 10cm gelassen werden.
6. Versperre niemals die Lüftungsschlitze und stelle das Produkt während des Betriebs nie in einen geschlossenen Behälter.
7. Sorge dafür, dass weder Fremdkörper noch Flüssigkeiten in das Geräteinnere gelangen. Verwende dieses Produkt niemals in der Nähe von Wasser.
8. Laufe niemals auf dem Netzkabel. Stelle keine schweren Gegenstände darauf, damit es nicht gequetscht oder anderweitig beschädigt wird. Besonders in der Nähe der Steckdose und der Anschlussbuchse am Verstärker muss das Kabel mit äußerster Vorsicht behandelt werden.
9. Löse den Netzanschluss, wenn du das Gerät längere Zeit nicht verwenden möchtest. Im Falle eines Gewitters muss der Netzanschluss gelöst werden.
10. Reinige diese Produkt nur mit einem feuchten Tuch.
11. Versuche niemals, das Erdungssystem des Netzsteckers zu umgehen. Ein geerdeter Stecker weist zwei Stifte und eine Erdungsöffnung auf. Die Erdung dient deiner Sicherheit. Wenn der beiliegende Stecker nicht in die Netzsteckdose passt, musst du einen Elektriker bitten, die Steckdose auszuwechseln.
12. Verwende nur Halterungen/Zubehörteile, die vom Hersteller ausdrücklich empfohlen werden.
13. Setze dich niemals über längere Zeiträume hohen Schallpegeln aus, weil das zu Hörschäden führen kann. Achte immer auf einen auch aus medizinischer Warte "vernünftigen" Pegel.

1 Hier die Gitarre anschließen

2 Speicher/Amp-Modelle

Jedem der vier Speicher ist ein anderes Verstärkermodell zugeordnet. Wir haben dir auch gleich "den" Sound für diese Modelle eingestellt. Drücke diese Taster der Reihe nach, um die Sounds anzuspielen. Um eigene "Schnappschüsse" aller Reglerpositionen (außer MASTER) zu speichern, musst du einen dieser Taster mindestens zwei Sekunden gedrückt halten. Damit löschst du dann aber die betreffenden Werkseinstellungen. Wenn die Einstellungen gespeichert sind, blinkt die Diode kurz.

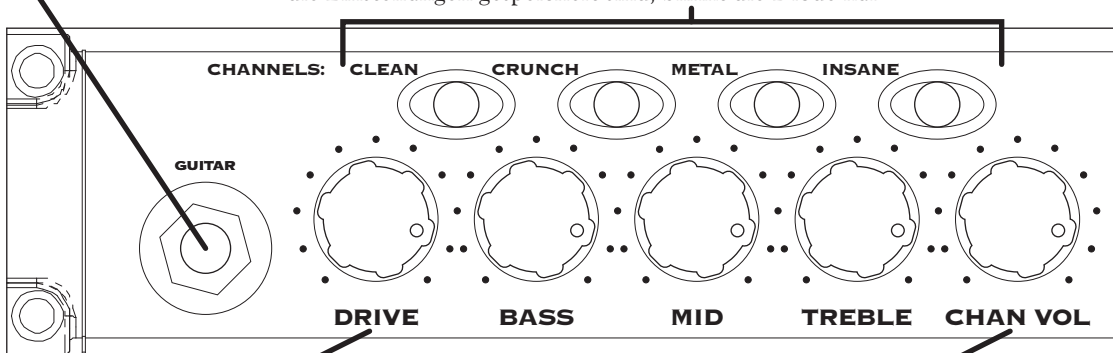

3 Klangregler
DRIVE entspricht dem Lautstärke- oder Gain-Regler anderer Verstärker: Hiermit stellst du den "Bratgehalt" des Sounds ein. Das genaue Verhalten von BASS, MID und TREBLE richtet sich nach dem momentan gewählten Speicher und folglich nach dem betreffenden Verstärkermodell.

4 Channel Vol
Mit diesem Regler sorgst du dafür, dass alle im Spider II gespeicherten Sounds ungefähr die gleiche Lautstärke haben. Weitere Hinweise zu den Speichern findest du unter (2).

6

Verzögerungszeit

Drücke den TAP-Taster mindestens zwei Mal im gewünschten Tempo, um die Verzögerungszeit des "Tape Echo"- oder "Sweep Echo"-Effekts einzustellen (sofern er aktiv ist). Die Diode leuchtet konstant, wenn der Halleffekt (Reverb) eingeschaltet ist und erlischt, wenn weder Echo, noch Hall verwendet wird. (Siehe außerdem "Extrafunktionen" des TAP-Tasters".)

9

Kopfhöreranschluss/Direktausgang

Schließe hier einen Kopfhörer an oder nutze diese Buchse als Direktausgang für Aufnahmezwecke. (Bei Anschließen einer Klinke an diese Buchse wird der interne Lautsprecher ausgeschaltet.)

10

FBV-Fußstereinheit (nicht beim Spider II 15)

Alles Weitere hierzu findest du unter "Arbeit für die Füße".

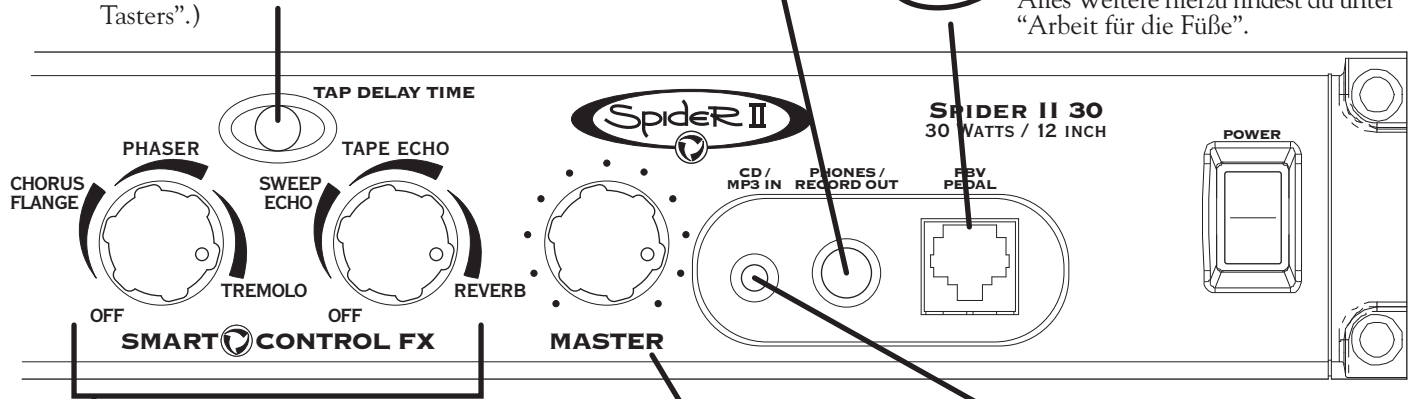
**5**

Smart Control FX

Mit diesen Reglern kann man sofort den gewünschten Effekt-Sound einstellen: Mit dem ersten Regler wählst du den Chorus/Flanger-, Phaser- oder Tremolo-Effekt. Die ebenfalls einstellbare Intensität reicht von "dezent" bis "umwerfend" – für jeden Effekt. Mit dem zweiten Regler wählst du Delay, Tape Echo, Sweep Echo oder Reverb. Außerdem kann die Balance zwischen dem Effekt und dem Originalsignal eingestellt werden. Wenn du einen Echoeffekt wählst, blinkt die TAP-Diode im Tempo der momentan verwendeten Verzögerungszeit. Drücke den Taster ein paar Mal, um einen anderen Wert einzustellen.

7

Master Volume

Die Wiedergabelautstärke hat keinerlei Einfluss auf den Sound und kann also frei gewählt werden.

8

CD/MP3-Eingang

An diese 1/8"-Buchse (Miniklinke) kann ein CD- oder MP3-Spieler angeschlossen werden, so dass du jederzeit mit deinen Helden spielen kannst.

Willkommen zum Spider II...

Vielen Dank, dass du einen Spider II abgeschleppt hast. Dieser Verstärker stellt so etwas wie die Synthese der beliebtesten Verstärker der vergangenen 40 Jahre dar, ergänzt diesen Schatz allerdings mit Möglichkeiten, die nur die digitale Signalverarbeitung bieten kann und die auch in 10 Jahren noch aktuell sein werden.

Jeder programmierbare Speicher beruht auf einem anderen Verstärkermodell:

Clean

Wähle dieses Modell und schraube an den Klangreglern, um "cleane" Sounds, darunter warme Jazz-Klänge, zu erzielen die nicht nur brillant daherkommen, sondern auch gehörig viel Druck im Bass machen. Dann fehlen eigentlich nur noch eine Prise Chorus und eine Idee Delay, um abzuheben!

Crunch

Ein sengender Plexi! Dieses Modell beruht auf einem aufgewerteten '68er 100W Marshall Plexi. Die Kombination eines Variac mit den gebrückten Eingangskanälen sorgt für jenen "Brown Sound", bei dem man fast den Eindruck hat, dass der Verstärker gleich verglüht! "Nichts für ungut, lieber Dave..."

Metal

Dieses Modell beruht auf dem Mesa Boogie Dual Rectifier. Dein Spider II wartet jedoch mit einigen Verschönerungen dieses klassischen Sounds auf. Daher klingt dieses Modell auch entsprechend moderner. Dieses Sound-Monster bietet einen gewaltigen, "tighten" und druckvollen Bassbereich. Wenn deine Metal-Songs richtig peitschen sollen, ist dies das passende Modell.

Insane

Hier war unser Ziel, den Pegel so stark anzuheben, dass die Verzerrung gerade an der Implosion des Amps vorbeischliddert. Die Verzerrung ist schon fast obszön, was jedoch niemals auf Kosten der Definition bzw. des Charakters geht. Daher ist der Bass entsprechend druckvoller und "boxiger" als bei anderen kleinen Amps. Drehe DRIVE auf und fahre Ohren und Haare ein – es pustet!

“Extrafunktionen” des TAP-Tasters

Der TAP-Taster dient nicht nur für die Einstellung der Delay-Verzögerungszeit. Hiermit kann man außerdem den Booster und das Noise Gate einstellen.

Booster für die Verzerrung

Halte den TAP-Taster gedrückt, während du den DRIVE-Regler auf einen Wert rechts der “12 Uhr”-Position stellst. Wenn die Verzerrung aktiv ist, leuchtet die CLEAN-Diode des Spider II. Der Sound wird entsprechend “dreckiger” – etwa wie bei einem Verzerrerpedal, dessen Distortion-Wert ganz klein und dessen Ausgangspegel ganz hoch eingestellt wird. Diese Pegelanhebung der Gitarre findet vor Erreichen des Verstärkermodells statt. Das Modell wird entsprechend höher ausgesteuert und zerrt also mehr als sonst.

Noise Gate

Halte den TAP-Taster gedrückt, während du den ECHO/REVERB-Regler auf einen Wert rechts der “12 Uhr”-Position stellst. Damit aktivierst du das Noise Gate, d.h. eine Schaltung, die Brummen und Rauschen unterdrückt, wenn man nicht spielt. Wenn das Gate aktiv ist, leuchtet die INSANE-Diode.

Spezielle verborgene Funktionen

Bei Anwahl eines Amp-Modells stellt der Spider II die Klangregelung und Effekte automatisch passend zu jenem Sound ein. Die automatische Effektanwahl (nicht aber die Änderungen der Klangregelung) kann man deaktivieren, indem man den INSANE-Taster gedrückt hält, während man den Spider II einschaltet. Beim nächsten Einschalten des Amps wird die Effektautomatik aber wieder aktiviert.

Bei Bedarf kannst du auch wieder die Werks-Sounds aufrufen, indem du CLEAN gedrückt hältst, während du den Spider II einschaltetest. **Warnung:** Hiermit ruinierst du ALLE Sounds, die du bis dahin gespeichert hast. Frage dich jetzt also: “Willst du das wirklich?” Wenn das “Ja” wie aus der Pistole geschossen kommt, darfst du.

Hinweis für Spider II HD75-Anwender

Die SPEAKER-Ausgänge des Spider II HD75 sind nur für 4Ω-Boxen ausgelegt. Boxen mit einer anderen Impedanz können eine Überhitzung des HD75 nach sich ziehen, wobei letzterer sich dann automatisch abschaltet.

Arbeit für die Füße (nur beim Spider II 30 & HD75)

Der Spider II 30 und HD75 erlauben die Verwendung einer von zwei Fußtastereinheiten: mit der FBV Express können Speicher direkt angewählt und das Tempo "getappt" werden. Mit einer FBV2 lassen sich die Speicher der Reihe nach anwählen. Und noch etwas: Die Pedaleinheiten FBV, FBV Shortboard, Floor Board und FB4 eignen sich nicht für den Spider II 30 bzw. HD75.

Die Bodentreter der FBV-Serie werden mit einem RJ-45-Kabel geliefert. Verbinde es mit dem passenden Anschluss auf der Frontplatte des Spider II und an der Seite der FBV. Falls du jemals ein Ersatzkabel brauchst: Verwende ein Cat-5-Kabel (oder besser) des Typs "10 Base-T" (alias RJ-45) mit männlichen Steckern an beiden Enden. Solche Kabel bekommt man übrigens in einem Computerfachgeschäft.

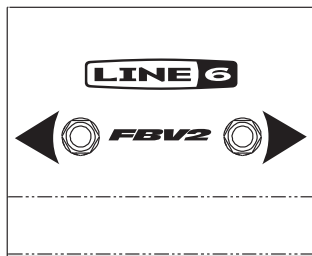

FBV2

Mit einer FBV2 kann man die Speicher vorwärts oder rückwärts anwählen. Betätige einen der beiden Fußtaster, um die vier Speicher des Spider II 30 bzw. HD75 ("Clean", "Crunch", "Metal" und "Insane") der Reihe nach aufzurufen.

FBV Express

Direktanwahl der vier Spider II-Speicher. Zum Einstellen einer Delay-Zeit brauchst du den leuchtenden Fußtaster nur zweimal im gewünschten Tempo zu drücken, um dich in den Groove des Drummers einzuklinken! Mit dem Zehenschalter des Pedals kannst du zwischen WahWah- und Volumenfunktion hin- und herschalten.

ACHTUNG: Die Stimmfunktion der FBV Express wird vom Spider II 30 und HD75 nicht unterstützt.

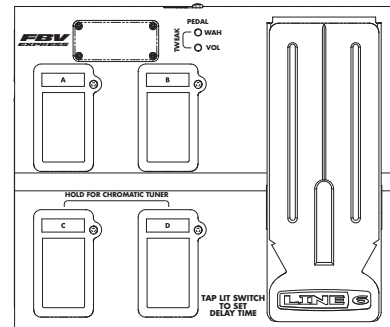

Deine schönsten Sounds

Zuerst einmal wollen wir dich darauf hinweisen, dass du unter www.line6.com tonnenweise neue Sound-Einstellungen findest. Außerdem kannst du auch deine Eigenkreationen verewigen, indem du angibst, welcher Speicher verwendet wurde und wie die einzelnen Regler eingestellt waren. Sogar das TAP-Tempo kannst du dir notieren.

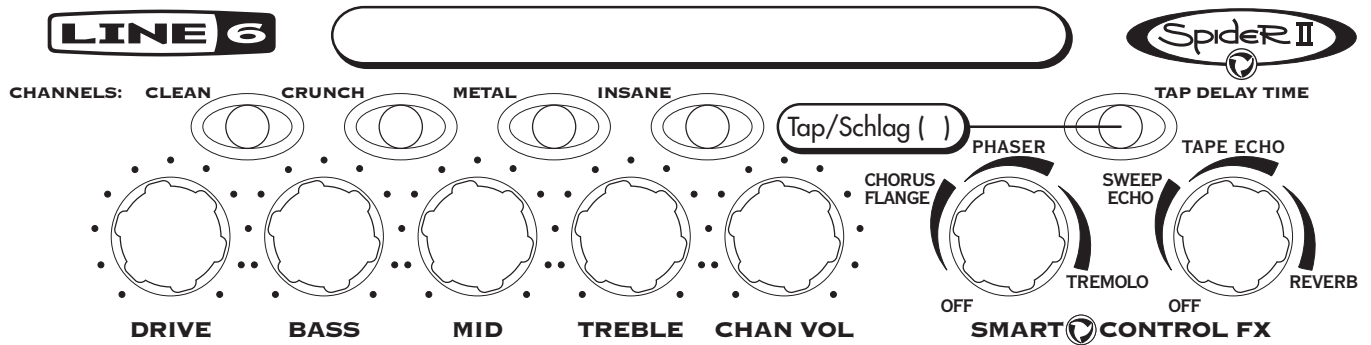
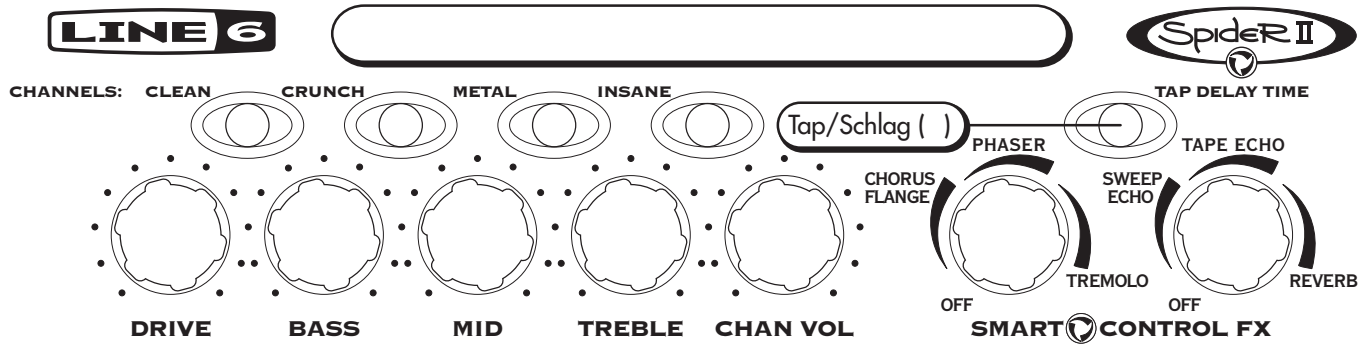

LINE 6



Spider II

CHANNELS: CLEAN

CRUNCH

METAL

INSANE

Tap/Schlag ()

TAP DELAY TIME

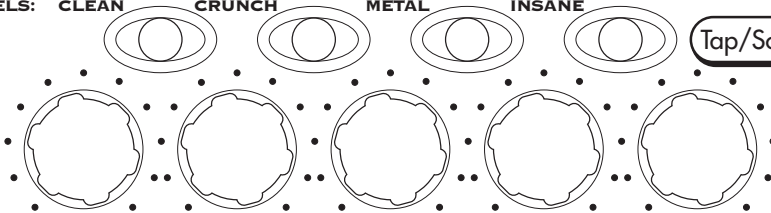

DRIVE

BASS

MID

TREBLE

CHAN VOL

CHORUS
FLANGE

PHASER

SWEEP
ECHO

TAPE ECHO

OFF

TREMOLO

OFF

REVERB

SMART CONTROL FX

LINE 6



Spider II

CHANNELS: CLEAN

CRUNCH

METAL

INSANE

Tap/Schlag ()

TAP DELAY TIME

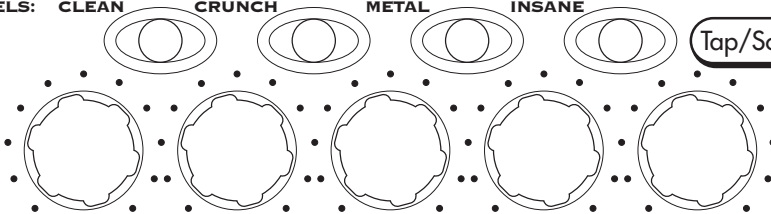

DRIVE

BASS

MID

TREBLE

CHAN VOL

CHORUS
FLANGE

PHASER

SWEEP
ECHO

TAPE ECHO

OFF

TREMOLO

OFF

REVERB

SMART CONTROL FX

LINE 6



CHANNELS: CLEAN

CRUNCH

METAL

INSANE

Tap/Schlag ()

TAP DELAY TIME

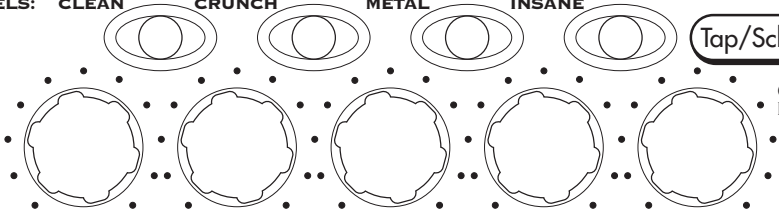

DRIVE

BASS

MID

TREBLE

CHAN VOL

CHORUS
FLANGE

PHASER

SWEEP
ECHO

TAPE ECHO

OFF

TREMOLO

OFF

REVERB

SMART CONTROL FX

LINE 6



CHANNELS: CLEAN

CRUNCH

METAL

INSANE

Tap/Schlag ()

TAP DELAY TIME

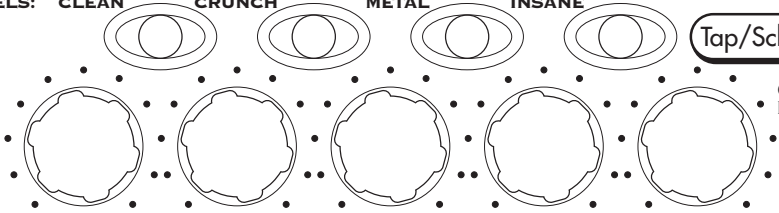

DRIVE

BASS

MID

TREBLE

CHAN VOL

CHORUS
FLANGE

PHASER

SWEEP
ECHO

TAPE ECHO

OFF

TREMOLO

OFF

REVERB

SMART CONTROL FX

Line 6, Spider II, FBV, FBV Shortboard, FBV4, FBV2, Floor Board, FB4 en Vetta zijn handelsmerken van Line 6, Inc. Alle andere productnamen, handelsmerken en namen van artiesten zijn eigendom van de betreffende bedrijven en personen, die op geen enkele manier aan Line 6 verbonden zijn. De productnamen, afbeeldingen, songtitels en namen van artiesten worden enkel gehanteerd als verwijzing naar de producten wier geluiden Line 6 tijdens de ontwikkeling van de modellen in dit product bestudeerd heeft. Het gebruik van productnamen, handelsmerken, afbeeldingen en namen van artiesten impliceert geen medewerking of ondersteuning.

VOORZICHTIG: Dit product werd uitvoerig getest. Daarbij is gebleken dat het, volgens “Part 15” van de Amerikaanse FCC Rules, beantwoordt aan de vereisten voor digitale “Class B”-apparaten. Meer bepaald moet het product aan de volgende eisen voldoen: (1) Het mag geen schadelijke interferenties veroorzaken en (2) het moet bestand zijn tegen eventueel ontvangen interferenties, die de werking op een onvoorspelbare manier zouden kunnen beïnvloeden.

WAARSCHUWING: Om het risico op brand en elektrocutie te beperken mag je dit product niet blootstellen aan regen of vochtigheid.



Het uitroepteken in een driehoek betekent “voorzichtig”. Lees altijd alle dingen door die met dit symbool zijn aangeduid.

VOORZICHTIG: Om het risico op brand en elektrocutie te beperken mag je nooit de schroeven verwijderen. Dit product bevat geen onderdelen die door de gebruiker hersteld mogen worden. Laat dit werk over aan een erkende technische dienst.



De bliksemschicht in een driehoek slaat op “elektrische waarschuwingen”. Meer bepaald maakt het symbool je attent op de aanwezigheid van instructies i.v.m. het voltage en mogelijke elektrocutie.



Dit symbool in een driehoek wijst op hete oppervlakken. Het bevindt zich meestal in de buurt van onderdelen die je tijdens het gebruik van dit product niet mag aanraken.



**Lees de volgende belangrijke veiligheidsinstructies door.
Bewaar deze instructies op een veilige plaats.**



Alvorens met de Spider II aan de slag te gaan moet je het volgende doornemen en alle punten en suggesties behartigen:

1. Volg alle waarschuwingen op de Spider II zelf en in dit Pilotenhandboek.
2. Sluit dit product enkel aan op een stopcontact met een netspanning van 100~120V of 200~240V/47~63Hz (zie het merkplaatje op het achterpaneel).
3. Voer alleen de in het Spider II-Pilotenhandboek uitdrukkelijk vermelde handelingen uit. In de volgende gevallen moet het product door een erkende herstellingsdienst nagekeken worden:
 - als het netsnoer of de stekker beschadigd is
 - als er vloeistoffen of andere voorwerpen in het inwendige terechtgekomen zijn
 - als dit product in de regen gestaan heeft of nat is geworden
 - als dit product niet meer naar behoren lijkt te werken
 - als het product gevallen of de ombouw beschadigd is.
4. Tijdens het gebruik wordt de onderkant van het chassis heet. Raak hem dus nooit tijdens of onmiddellijk na het gebruik aan.
5. Plaats het product nooit in de buurt van warmtebronnen, zoals radiatoren, stoven of andere apparaten die tijdens het gebruik heet worden. Laat een afstand van minstens 10cm tussen de achterkant van het product en de muur of andere voorwerpen die de verluchting versperren.
6. Blokkeer nooit de ventilatieopeningen en plaats het product nooit in een hermetisch afgesloten behuizing.
7. Zorg dat er geen vloeistoffen of kleine voorwerpen in dit product terechtkomen. Zet het nooit in de buurt van water.
8. Ga nooit op het netsnoer staan. Zet geen zware voorwerpen op het netsnoer om te voorkomen dat het gekneusd of beschadigd wordt. Wees met name voorzichtig in de buurt van de aansluiting op de versterker.
9. Verbreek de aansluiting op het lichtnet, als je dit product langere tijd niet wilt gebruiken. Tijdens een onweer moet je de aansluiting op het lichtnet verbreken.
10. Maak het apparaat met een vochtige doek schoon.
11. Probeer nooit de aarding van de netstekker te omzeilen. Een geaarde stekker heeft twee pinnen en een opening. De derde opening is er voor je veiligheid. Als de bijgeleverde stekker niet in het stopcontact past, moet je aan een elektricien vragen het contact te vervangen.
12. Gebruik uitsluitend houders/accessoires die door de fabrikant uitdrukkelijk worden aanbevolen.
13. Het luisteren op een pittig volume kan leiden tot gehoorverlies – en zoets is onomkeerbaar. Zet het volume dus nooit overdreven hard.

1 Sluit hier de gitaar aan

2 **Geheugens/versterkermodellen**

De vier geheugens berusten telkens op een ander versterkermodel. Bij levering bevatten ze bovendien al geschikte instellingen voor de betreffende sound. Druk deze knoppen achtereenvolgens in om de geluiden te beluisteren. Eigen "snapshots" van alle regelaars (met uitzondering van MASTER) kun je opslaan door de knop van het gewenste geheugen minstens twee seconden ingedrukt te houden. Zodra de instellingen opgeslagen zijn, knippert de indicator even.

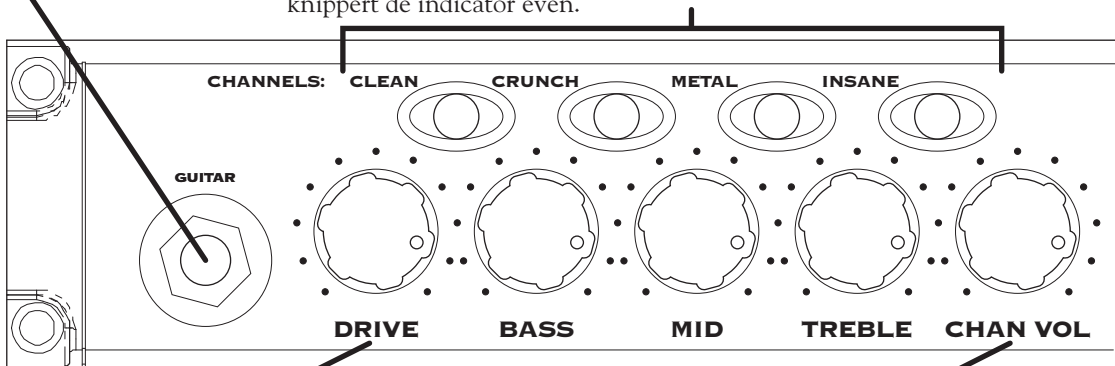

3 **Toonregelaars**
DRIVE komt overeen met de volume- of gainregelaar op andere versterkers: hiermee bepaal je namelijk de hoeveelheid "scheur". De precieze werking van BASS, MID en TREBLE verschilt naar gelang het gekozen geheugen (en dus versterkermodel).

4 **Channel Vol**
Met deze regelaar zorg je dat de in de Spider II opgeslagen sounds (versterker + effecten) ongeveer hetzelfde volume hebben. Meer details over de geheugens vind je onder (2).

6 Vertragingstijd

Druk de TAP-knop minstens twee keer in om de vertragingstijd voor het "Tape Echo"- of "Sweep Echo"-effect in te stellen (als het actief is). De indicator licht op (en stopt met knipperen), wanneer je het reverbeffect activeert; hij dooft, als je noch echo, noch reverb gebruikt. (Zie ook "Extrafuncties" van de TAP-knop".)

9 Hoofdtelefoon-/directuitgang

Je kunt een hoofdtelefoon op deze connector aansluiten of hem als directe uitgang voor opnametoepassingen gebruiken! (Zodra je hier iets aansluit, wordt de interne luidspreker uitgeschakeld.)

10 FBV-pedaaleenheid (niet op de Spider II 15)

Meer details hierover vind je onder "Werk voor de voeten".

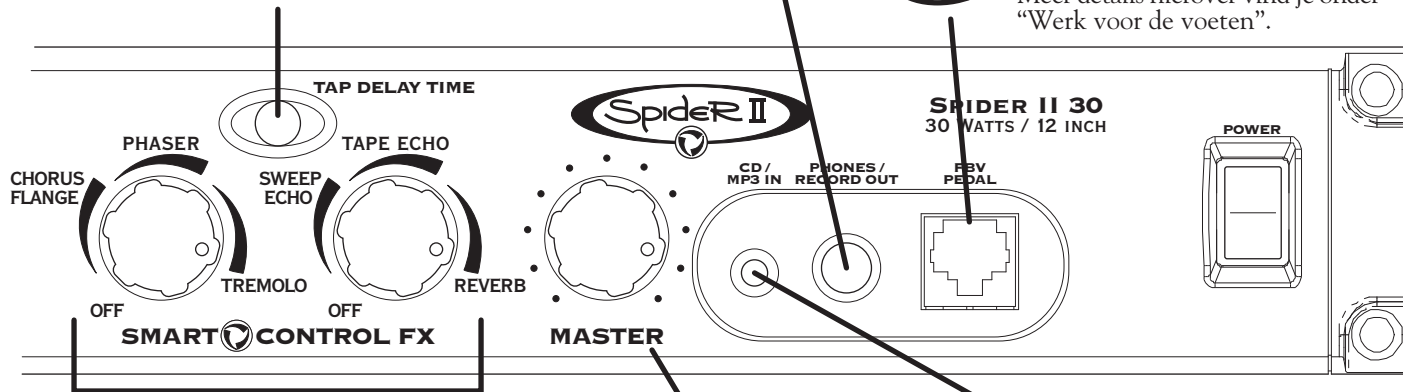

5

Smart Control FX

Met deze regelaars kun je in een mum van tijd het gewenste effectgeluid instellen: Met de eerste regelaar kies je het chorus/flanger-, phaser- of tremolo-effect. De hoeveelheid effect kan ergens tussen een "vleugje" en "pakken effect" liggen. Via de tweede regelaar kies je Delay, Tape Echo, Sweep Echo of reverb. Bovendien kun je er de balans tussen het ingangs- en het effectsignaal mee instellen. Als je een echo-effect kiest, knippert de indicator van de TAP-knop in de maat. Druk verschillende keren op de knop om een andere vertragingstijd in te stellen.

7

Algemeen volume

Het weergavevolume heeft geen enkele invloed op het geluid als dusdanig en kan dus naar keuze worden ingesteld.

8

CD/MP3-ingang

Sluit een CD- of MP3-speler op deze 1/8"-ingang (mini-jack) aan om je door je favoriete bands te laten begeleiden.

Welkom bij de Spider II...

Bedankt dat je een Spider II mee naar huis genomen hebt. Deze versterker is zowat een synthese van de meest gegeerde versterkers van de afgelopen 40 jaar, maar voegt daar mogelijkheden aan toe die alleen digitale apparaten kunnen bieden en die ook binnen 10 jaar nog up-to-date zullen zijn.

Elk van de vier geheugens berust op een ander versterkermodel en levert dus een compleet andere sound op:

Clean

Kies dit model en draai wat aan de toonregelaars om verrassend “cleane” sounds, waaronder ook warme jazzklanken, te verkrijgen, die niet enkel helder zijn, maar in de bas ook behoorlijk kunnen pompen. Dan ontbreken eigenlijk alleen nog een vleugje chorus en een lepeltje delay om te kunnen zweven!

Crunch

Een gloedhete Plexi! Dit model berust op een 100W Marshall Plexi uit '68. De combinatie van een Variac met de overbrugde ingangskanalen levert de typische “Brown Sound” op die de indruk wekt dat je amp zo meteen begint te smelten! “Even goede vrienden, hé Dave...?”

Metal

Dit model berust op een Mesa Boogie Dual Rectifier. Jouw Spider II verbetert dit “klassieke” geluid echter op een aantal punten. Vandaar dat dit model iets moderner klinkt. Dit soundmonster heeft een grootse bas met veel druk, power en een snelle respons. Als je echt tot aan de Metal-pijngrens wil gaan, moet je gewoon dit model kiezen.

Insane

Met dit model wilden we het niveau zó ver opkrikken tot de versterker net niet ontploft. De vervorming is al bijna onmenselijk, hoewel dit nooit ten koste van de definitie of het karakter gaat. Dat zorgt er meteen voor dat de bas veel meer blaast en dat het geluid “meer buik” heeft dan op andere kleine versterkers. Draai DRIVE helemaal open en klap je oren dicht – zo meteen barst namelijk de hel los!

“Extrafuncties” van de TAP-knop

De TAP-knop dient niet alleen voor het instellen van de vertragingstijd. Je kunt er tevens de booster en noisegate mee instellen.

Distortion Boost

Houd de TAP-knop ingedrukt, terwijl je de DRIVE-regelaar op een waarde voorbij “12 uur” zet. Als je dit doet, licht de indicator van de CLEAN-knop op de Spider II op. Het geluid wordt nog “smeriger” – ongeveer zoals bij een vervormingpedaaltje met een kleine vervormingswaarde en een hoog uitgangsvolume. Het gitaarniveau wordt vóór het versterkermodel opgehaald. Hierdoor wordt het model veel intenser aangestuurd en begint het dus sneller te scheuren.

Noisegate

Houd de TAP-knop ingedrukt, terwijl je de REVERB-regelaar op een waarde voorbij “12 uur” zet. Daarmee schakel je de noisegate in, d.w.z. een schakeling die brom en ruis onderdrukt, wanneer je niets speelt. Als de gate actief is, licht de INSANE-indicator op.

Speciale verborgen functies

Tijdens de keuze van een versterkermodel maakt de Spider II automatisch de bijpassende instellingen voor de effecten en de toonregeling. De automatische effectkeuze (maar niet de instellingen van de toonregeling) kun je deactiveren door de INSANE-knop ingedrukt te houden, terwijl je de Spider II inschakelt. Als je de versterker daarna opnieuw inschakelt, wordt de automatische effectkeuze echter weer geactiveerd.

Indien nodig, kun je opnieuw de voorgeprogrammeerde sounds laden door CLEAN ingedrukt te houden, terwijl je de Spider II inschakelt. **Waarschuwing:** Hiermee overschrijf je ALLE sounds die je misschien al geprogrammeerd hebt. Stel je dus de vraag: “Wil je dat echt?” Als het bevestigende antwoord meteen komt, mag je je gang gaan.

Opmerking voor Spider II HD75-gebruikers

De speakeruitgangen van de Spider II HD75 zijn uitsluitend voor 4Ω-ladingen geschikt. Speakers met een andere impedantie zorgen er eventueel voor dat de HD75 oververhit en automatisch uitgeschakeld wordt.

Werk voor de voeten (Alleen voor de Spider II 30 & HD75)

De Spider II 30 en HD75 laten het gebruik van twee voetschakelaareenheden toe: een FBV Express voor de geheugenkeuze en het “tappen” van de vertragingstijd, of een FBV2 voor het selecteren van geheugens. Onthoud wel dat je geen FBV, FBV Shortboard of FB4 met de Spider II 30 en HD75 kunt gebruiken.

Een FBV wordt met een RJ-45-aansluitkabel geleverd. Verbind die kabel met de connector op het frontpaneel van de Spider II en aan de zijkant van je FBV. Als de kabel ooit stuk gaat, kun je een Cat-5 (of beter), “10 Base-T”- of “RJ-45-kabel” met mannelijke stekkers gebruiken, die je bv. in een computerzaak vindt.

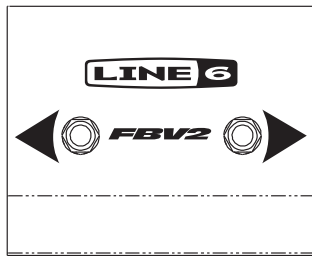

FBV2

De FBV2 biedt twee voetschakelaars voor het doorlopen van de geheugens. Trap één van beide in om de geheugens (“Clean”, “Crunch”, “Metal” en “Insane”) van de Spider II 30 of HD75 één voor één op te roepen.

FBV Express

Trap een voetschakelaar in om het gewenste geheugen van de Spider II te kiezen. Wil je de vertragingstijd veranderen? Trap de oplichtende voetschakelaar minstens twee keer in de maat van de drummer in en je bent op dreef! Trap de tip van het pedaal in om de wah- of volumefunctie te kiezen.

OPMERKING: De tuner van de FBV Express wordt door de Spider II 30 en HD75 niet ondersteund.

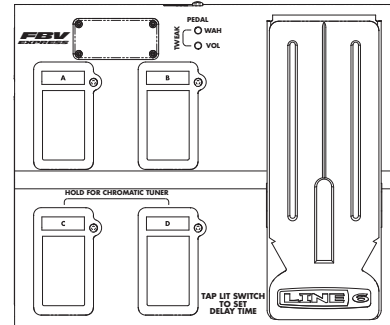

Je mooiste sounds

Als je wilt, vind je op www.line6.com tal van instellingen voor de meest uiteenlopende muziekstijlen. Bovendien kun je hier natuurlijk ook je eigen instellingen vasthouden door de standen van de regelaars –en zelfs de TAP-instelling– te noteren.

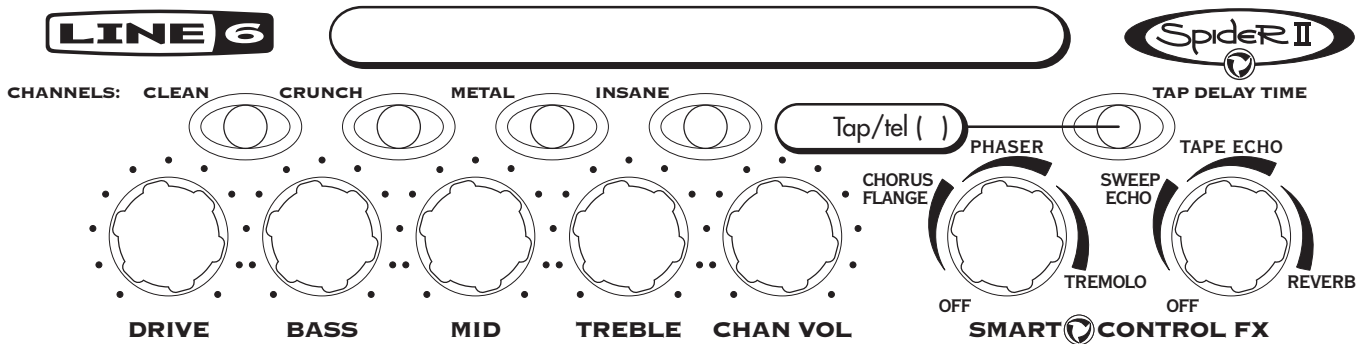
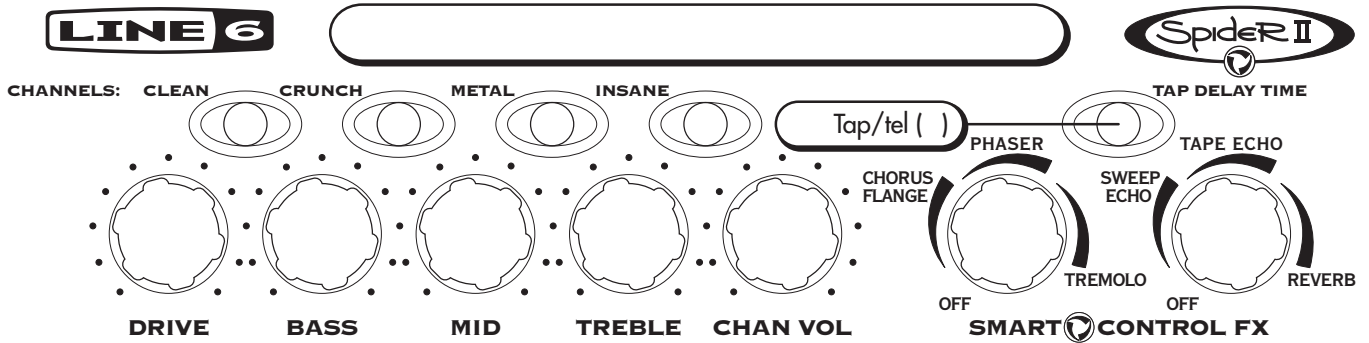

LINE 6



Spider II

CHANNELS: CLEAN

CRUNCH

METAL

INSANE

Tap/tel ()

TAP DELAY TIME

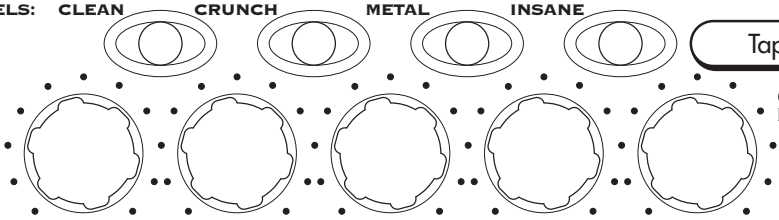

DRIVE

BASS

MID

TREBLE

CHAN VOL

CHORUS
FLANGE

PHASER

SWEEP
ECHO

TAPE ECHO

OFF

TREMOLO

REVERB

SMART CONTROL FX

LINE 6



Spider II

CHANNELS: CLEAN

CRUNCH

METAL

INSANE

Tap/tel ()

TAP DELAY TIME

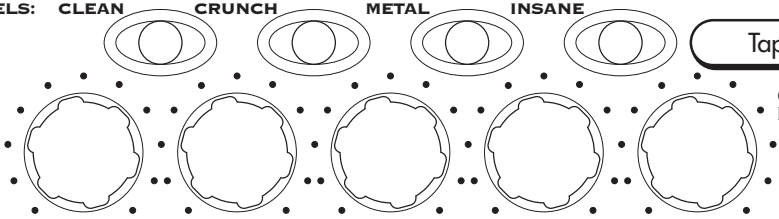

DRIVE

BASS

MID

TREBLE

CHAN VOL

CHORUS
FLANGE

PHASER

SWEEP
ECHO

TAPE ECHO

OFF

TREMOLO

REVERB

SMART CONTROL FX

LINE 6



CHANNELS: CLEAN

CRUNCH

METAL

INSANE

Tap/tel ()

TAP DELAY TIME

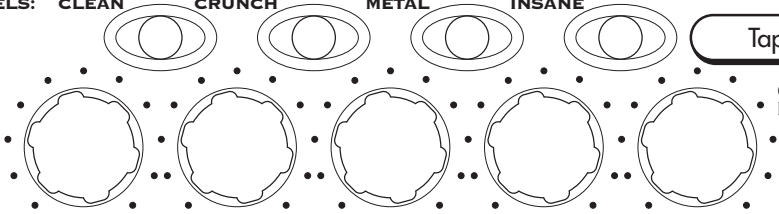

DRIVE

BASS

MID

TREBLE

CHAN VOL

CHORUS
FLANGE

PHASER

SWEEP
ECHO

TAPE ECHO

OFF

TREMOLO

OFF

REVERB

SMART CONTROL FX

LINE 6



CHANNELS: CLEAN

CRUNCH

METAL

INSANE

Tap/tel ()

TAP DELAY TIME

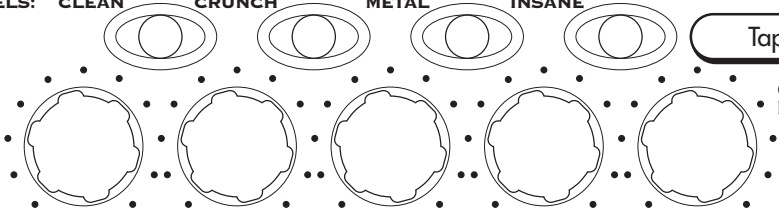

DRIVE

BASS

MID

TREBLE

CHAN VOL

CHORUS
FLANGE

PHASER

SWEEP
ECHO

TAPE ECHO

OFF

TREMOLO

OFF

REVERB

SMART CONTROL FX