

Digitech	
8760 South Sandy Parkway Sandy, Utah 84070	
Title RP-20 MAIN BOARD	
Size B	Document Number 055308A0.001
Date: Tuesday, March 28, 2000	Rev A0
Sheet 1 of 9	

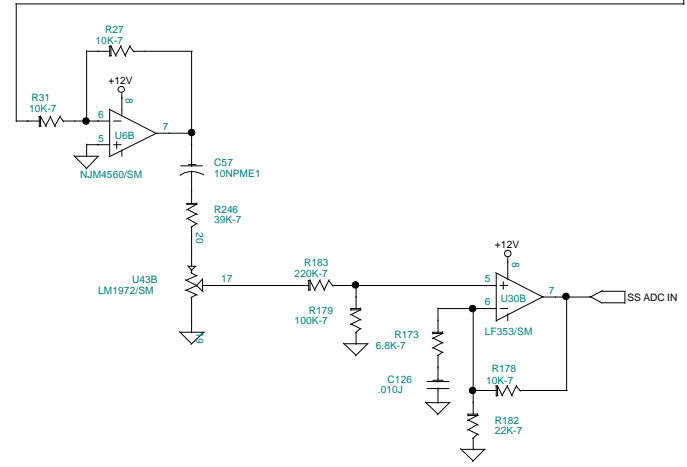

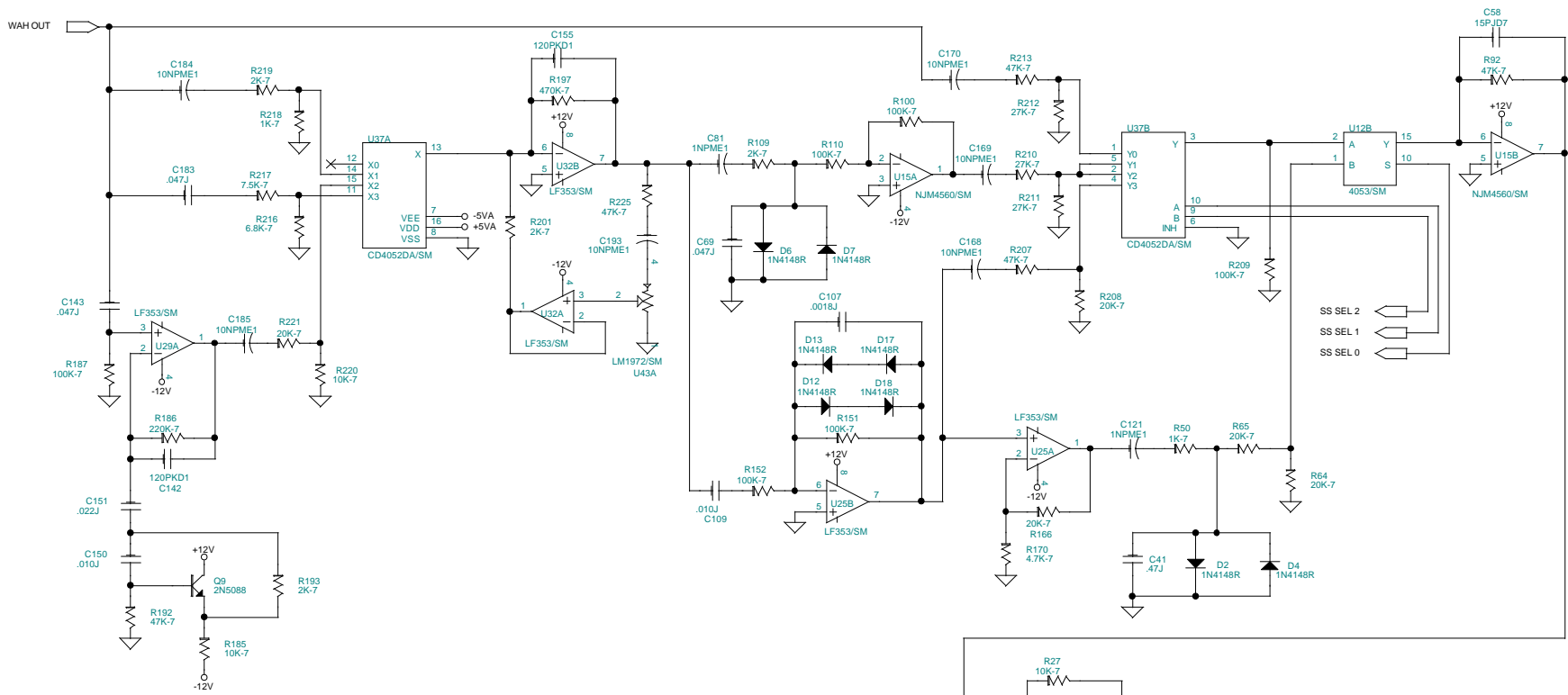

Digitech	
8760 South Sandy Parkway Sandy, Utah 84070	
Title RP-20 MAIN BOARD	
Size B	Document Number 055308A0.003
Date: Tuesday, March 28, 2000	Rev A0
Sheet 3 of 9	

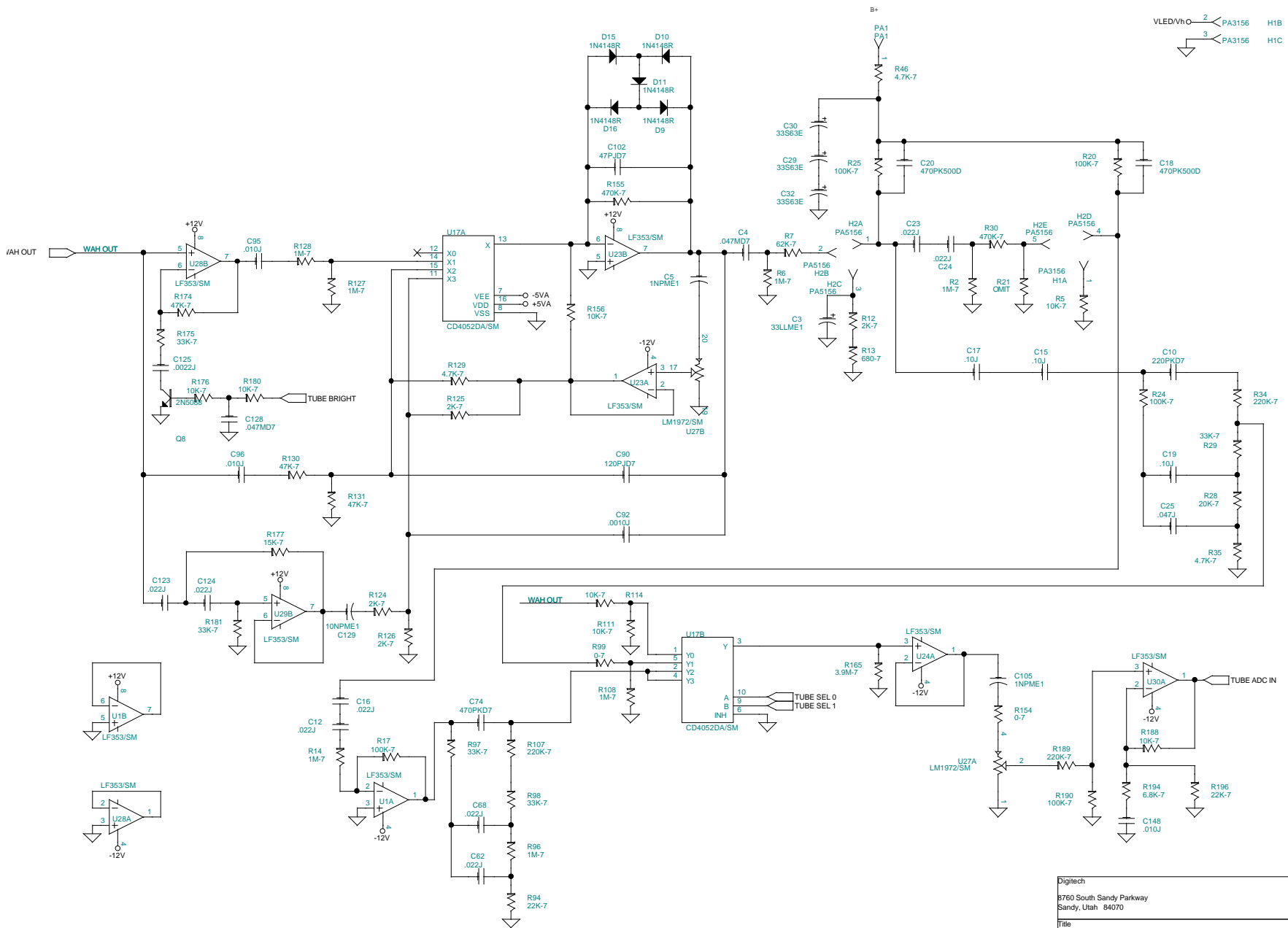
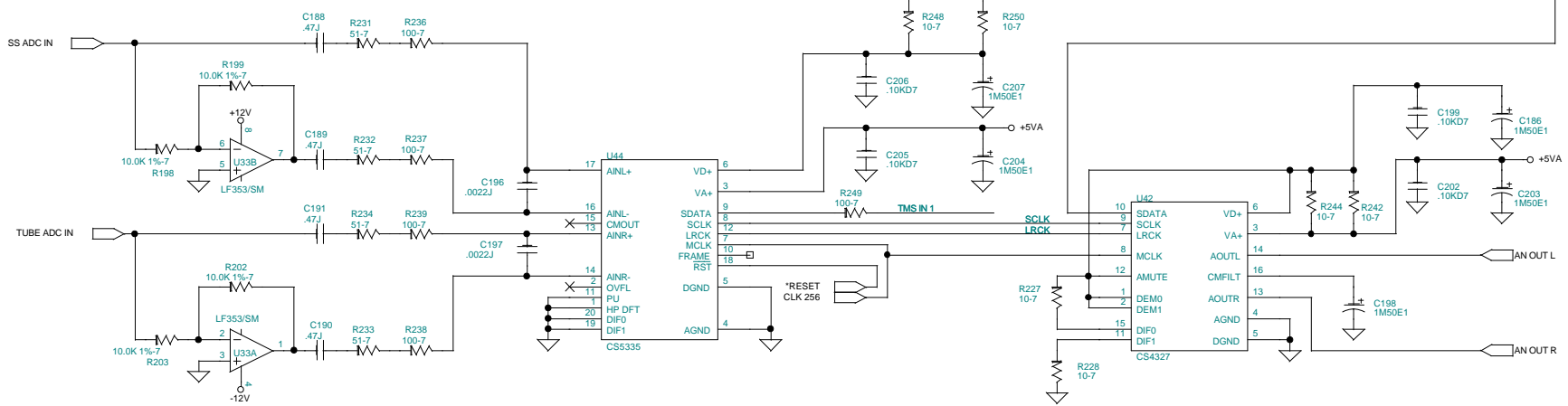
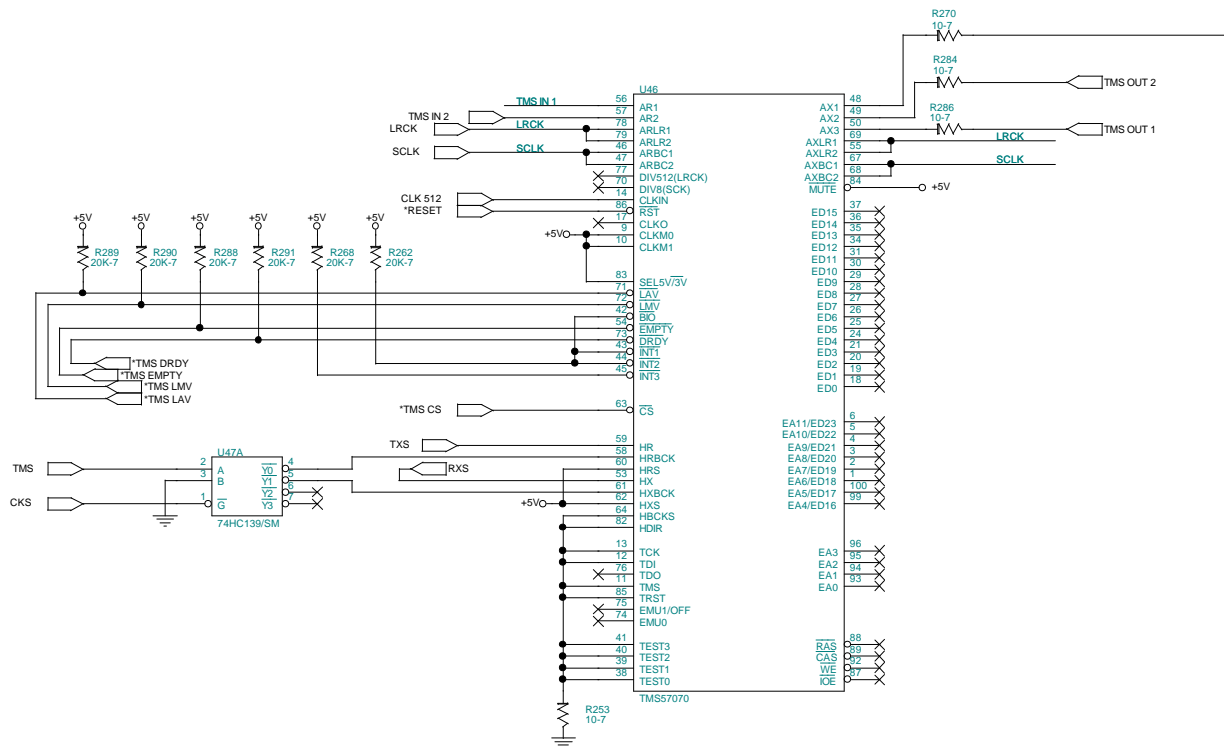

Digitech		
8760 South Sandy Parkway Sandy, Utah 84070		
Title		
RP-20 MAIN BOARD		
Size	Document Number	Rev
B	055308A0.004	A0
Date:	Tuesday, March 28, 2000	Sheet 4 of 9

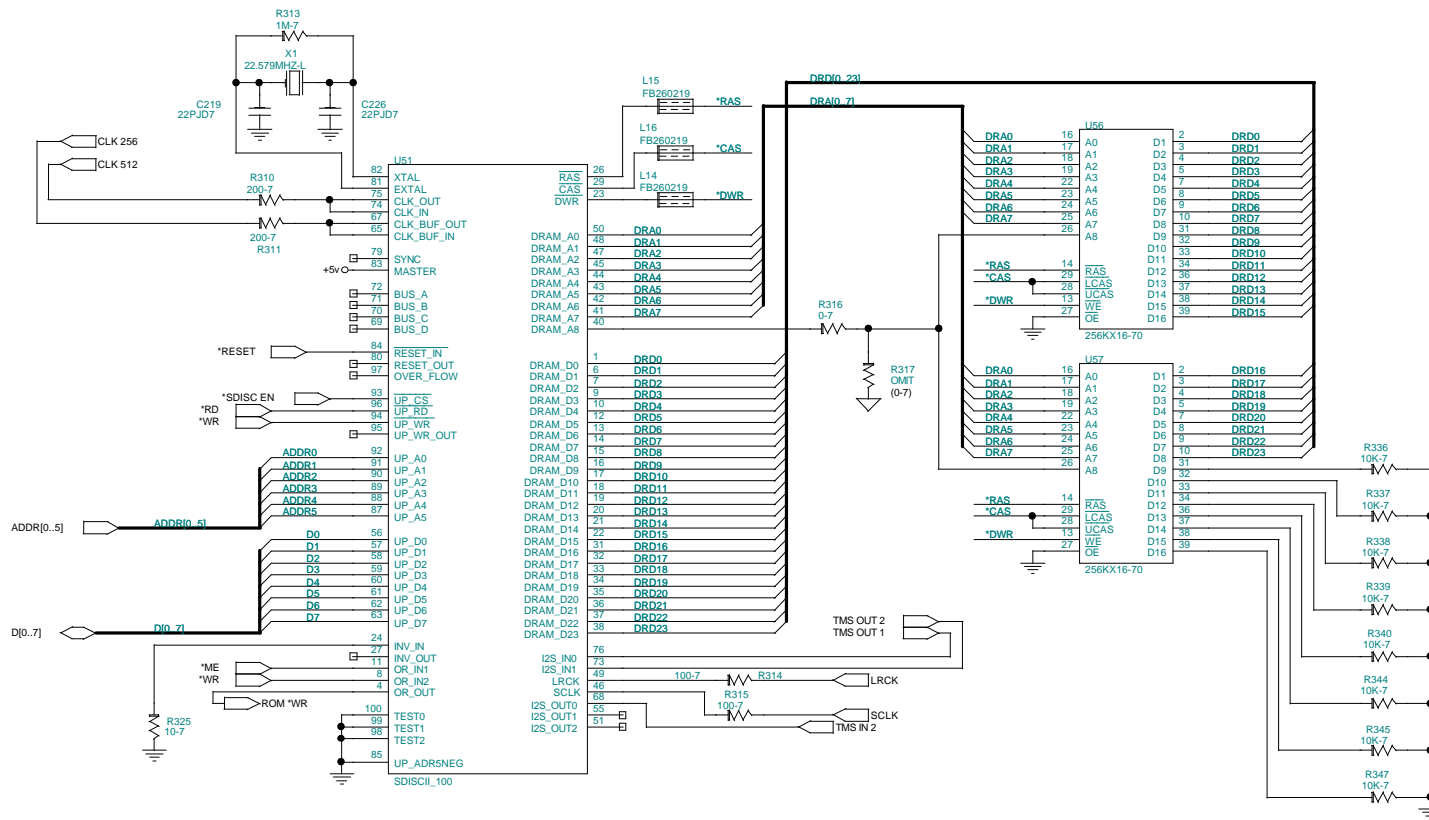

Digitech		
8760 S. Sandy Parkway Sandy, UT 84070		
Title RP-20 MAIN BOARD		
Size B	Document Number 055308A0.005	Rev A0
Date:	Tuesday, March 28, 2000	Sheet 5 of 9

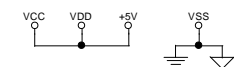
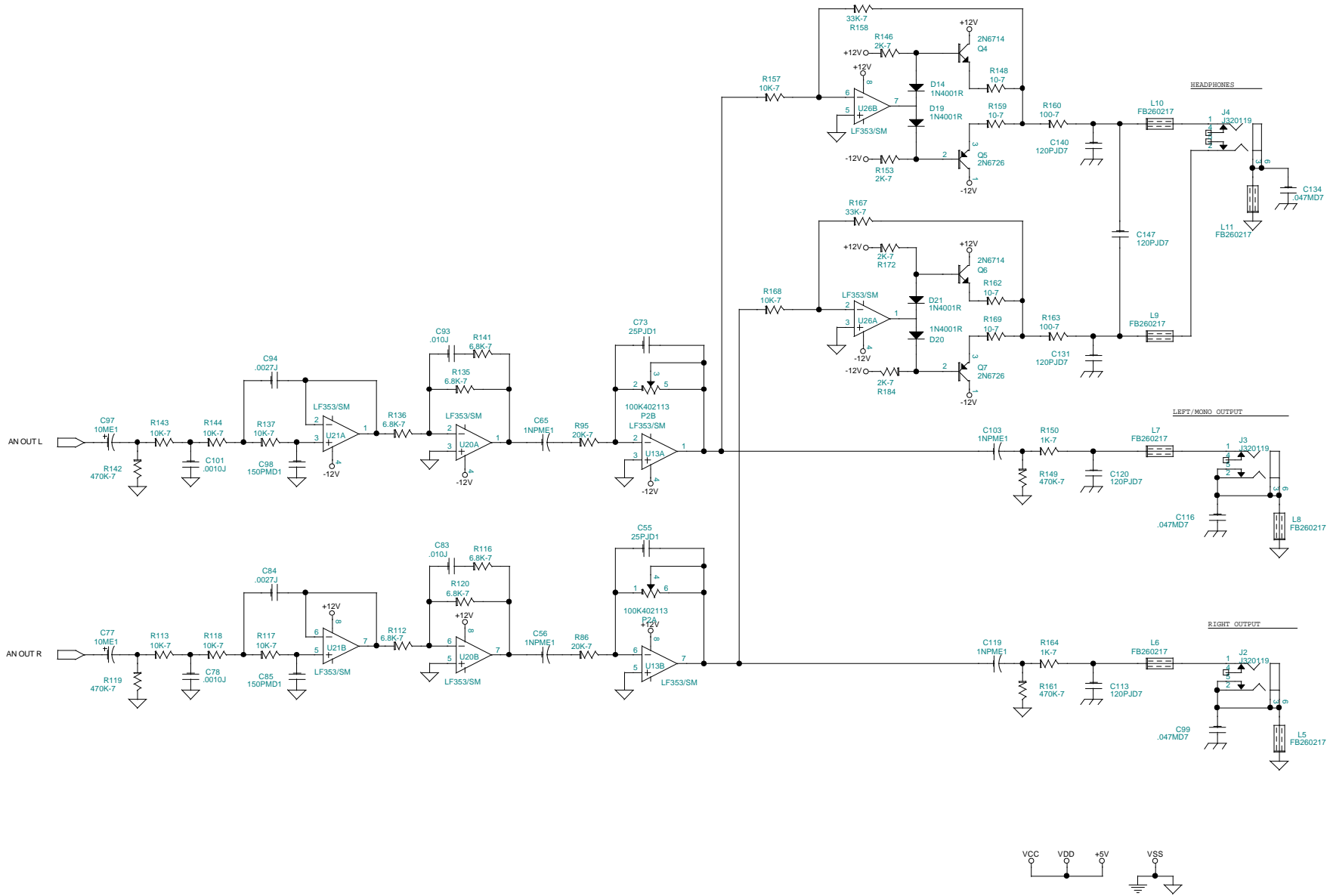

Digitech	
8760 South Sandy Parkway Sandy, Utah 84070	
Title RP-20 MAIN BOARD	
Size B	Document Number 055308A0.006
Date: Tuesday, March 28, 2000	Rev A0
Sheet 6 of 9	

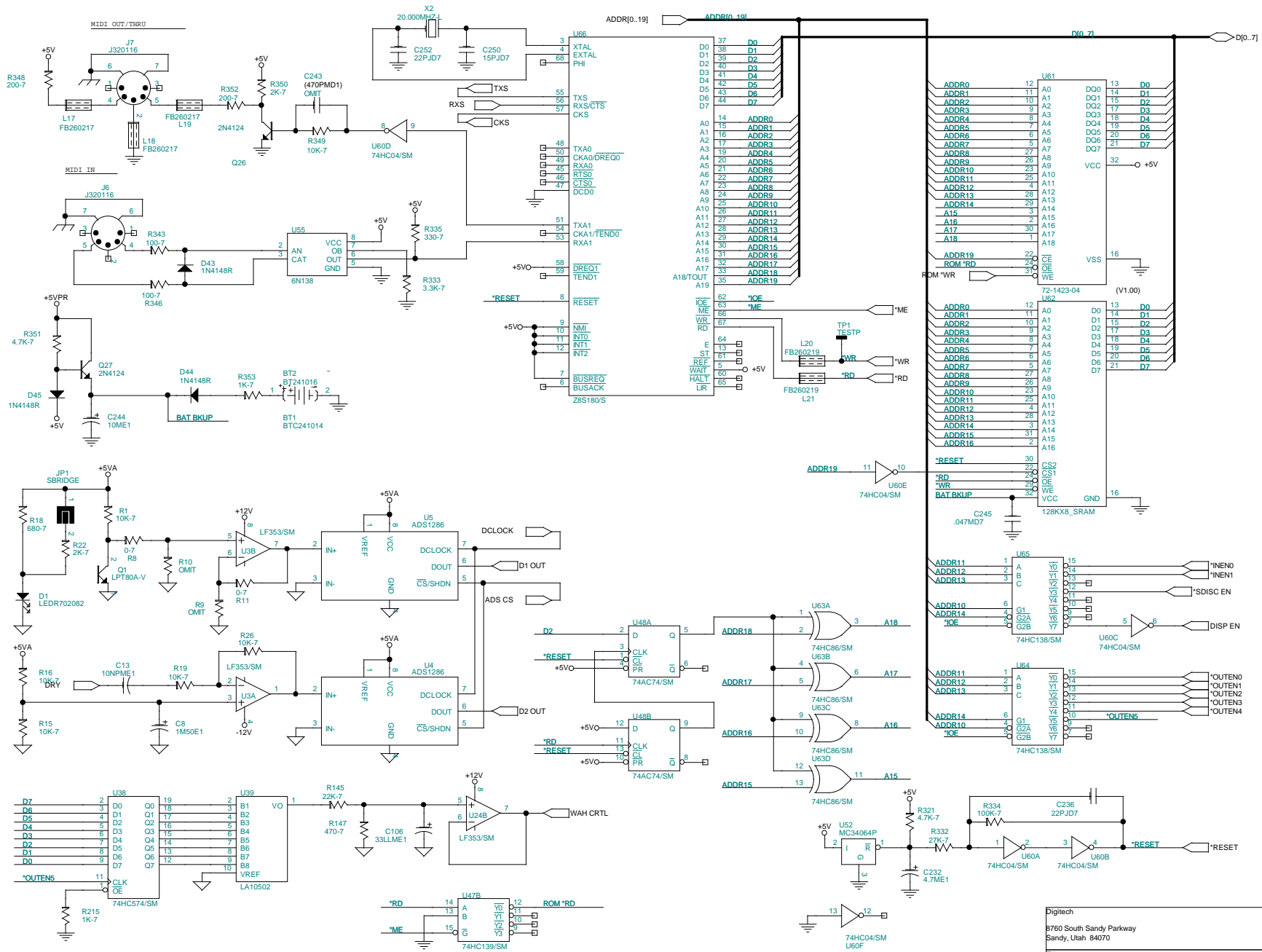

Digitech		
8760 South Sandy Parkway Sandy, Utah 84070		
Title RP-20 MAIN BOARD		
Size B	Document Number 055308A0.007	Rev A0
Date: Tuesday, March 28, 2000	Sheet 7 of 9	

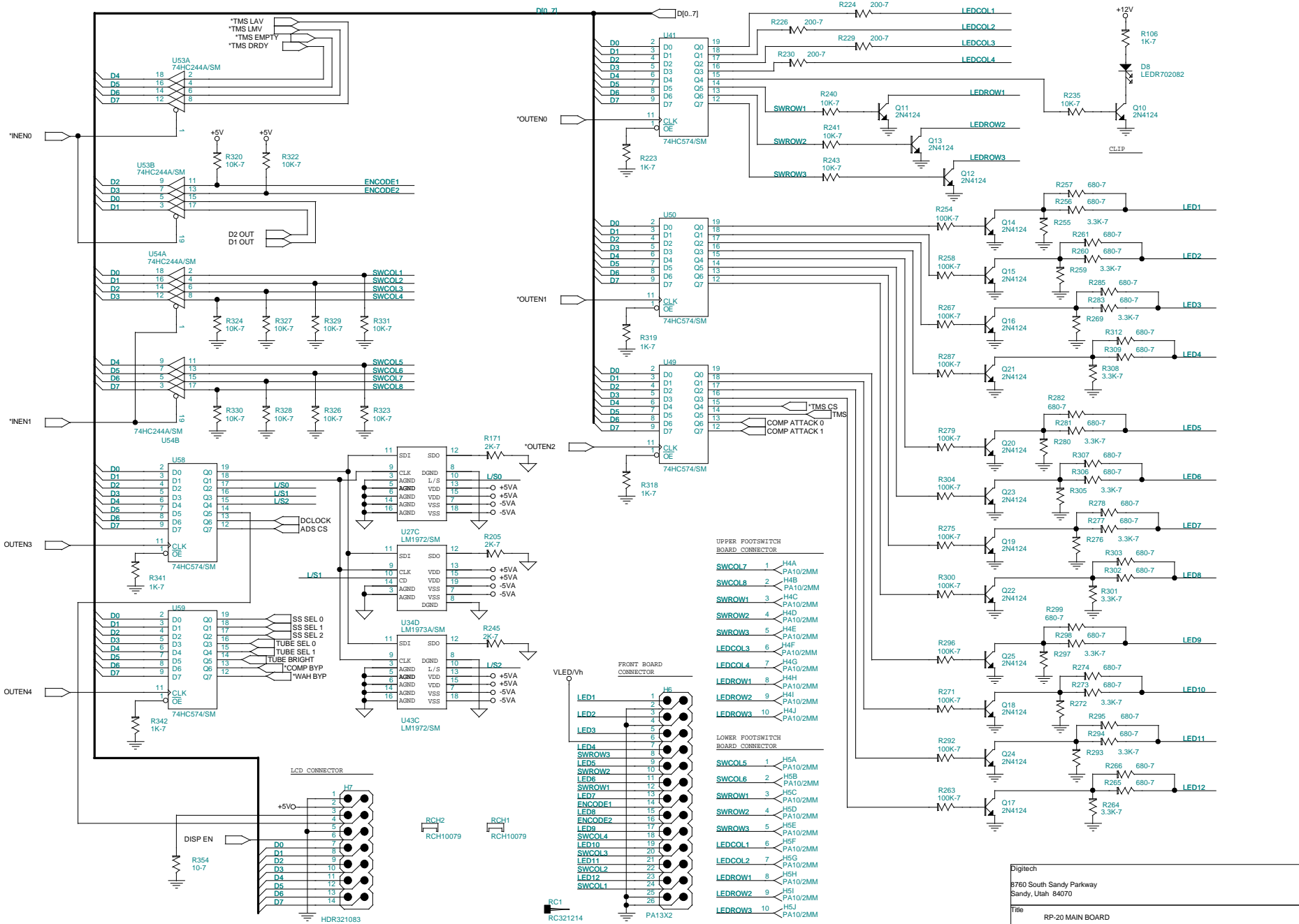

- UPPER FOOTSWITCH BOARD CONNECTOR
- SWCOL7 1 H4A PA10/2MM
 - SWCOL8 2 H4B PA10/2MM
 - SWROW1 3 H4C PA10/2MM
 - SWROW2 4 H4E PA10/2MM
 - SWROW3 5 H4F PA10/2MM
 - LEDCOL3 6 H4F PA10/2MM
 - LEDCOL4 7 H4G PA10/2MM
 - LEDROW1 8 H4H PA10/2MM
 - LEDROW2 9 H4I PA10/2MM
 - LEDROW3 10 H4J PA10/2MM
- LOWER FOOTSWITCH BOARD CONNECTOR
- SWCOL5 1 H5A PA10/2MM
 - SWCOL6 2 H5B PA10/2MM
 - SWROW1 3 H5C PA10/2MM
 - SWROW2 4 H5D PA10/2MM
 - SWROW3 5 H5E PA10/2MM
 - LEDCOL1 6 H5F PA10/2MM
 - LEDCOL2 7 H5G PA10/2MM
 - LEDROW1 8 H5H PA10/2MM
 - LEDROW2 9 H5I PA10/2MM
 - LEDROW3 10 H5J PA10/2MM

Digitech	
8760 South Sandy Parkway Sandy, Utah 84070	
Title RP-20 MAIN BOARD	
Size B	Document Number 055308A0.008
Date: Tuesday, March 28, 2000	Rev A0

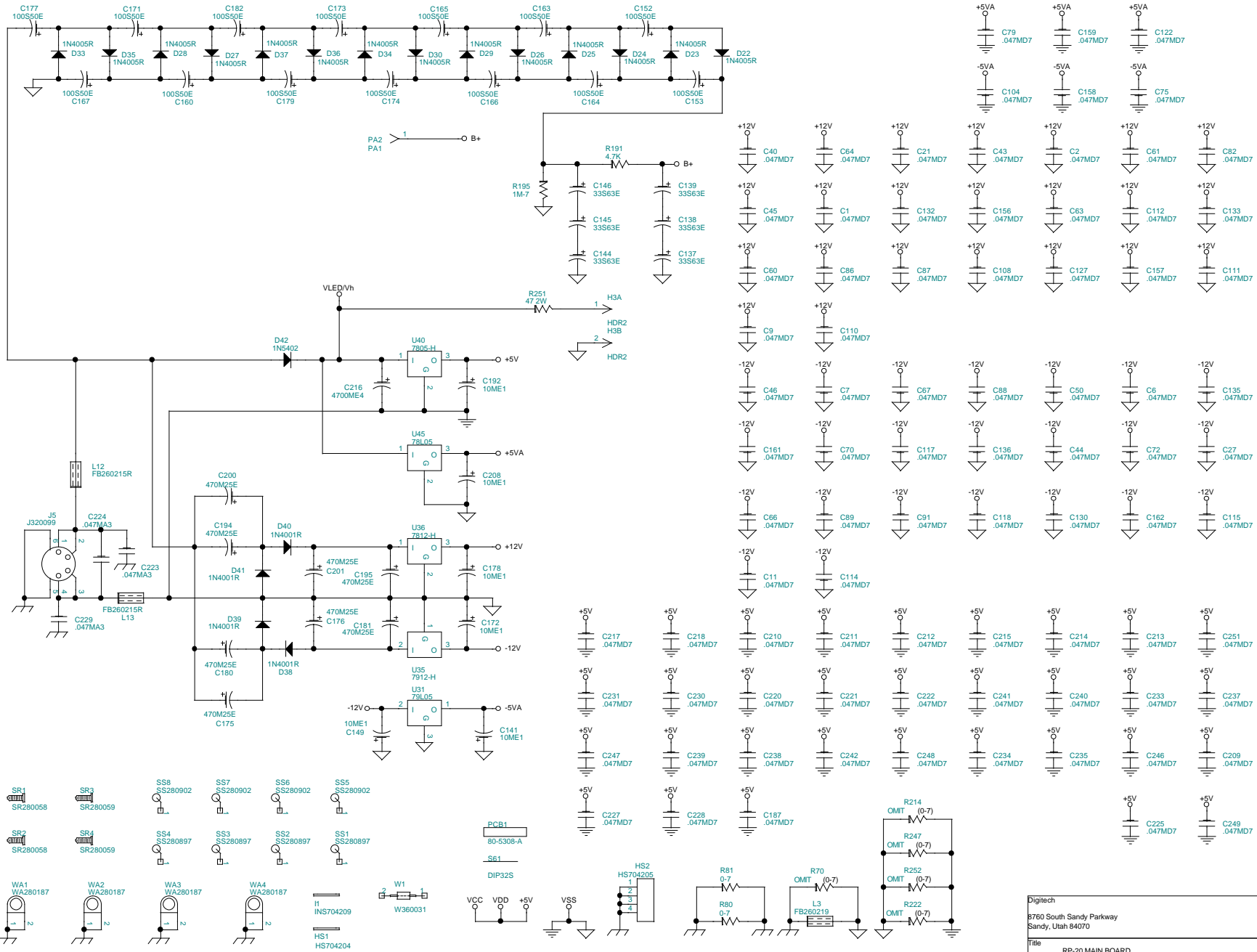

Digitech	
8760 South Sandy Parkway Sandy, Utah 84070	
Title RP-20 MAIN BOARD	
Size B	Document Number 055308A0.009
Date: Tuesday, March 28, 2000	Rev A0
Sheet 9	of 9

&l0 (s0P (s15H (s8V (s0S &l6D &l66P &l3E &a7L &a120M &l61FDOD Software

Page 1

RP-20 MAIN BOARD

055308A0.000

Bill Of Materials

Quan Reference

Revised: July 22, 1997

Revision: A0

July 30, 1997 15:11:34

Part SYMAN Description

Quan	Reference	Part	SYMAN	Description
1	BT1	BTC241014	24-1014	Holder For 3V Battery
1	BT2	BT241016	24-1016	3V Battery, Lithium, Eveready Part #CR2032
92	C1,C2,C4,C6,C7,C9,C11, C21,C27,C38,C40,C43,C44, C45,C46,C48,C50,C60,C61, C63,C64,C66,C67,C70,C72, C75,C79,C82,C86,C87,C88, C89,C91,C99,C104,C108, C110,C111,C112,C114,C115, C116,C117,C118,C122,C127, C128,C130,C132,C133,C134, C135,C136,C156,C157,C158, C159,C161,C162,C187,C209, C210,C211,C212,C213,C214, C215,C217,C218,C220,C221, C222,C225,C227,C228,C230, C231,C233,C234,C235,C237, C238,C239,C240,C241,C242, C245,C246,C247,C248,C249, C251	.047MD7	62-3129	.047 uF Cap 50V 20% Cerm SMT 0805
2	C3,C106	33LLME1	60-0059-01	33 uF Cap 16V 20% Elect., LL T&R
8	C5,C56,C65,C81,C103,C105, C119,C121	1NPMEE1	60-0046-01	1.0 uF Cap 16V -20/+20% Elect., N.P. T&R
7	C8,C28,C186,C198,C203, C204,C207	1M50E1	60-0044-01	1.0 uF Cap 50V -20/+20% Elect., T&R C&F
2	C10,C35	220PKD7	62-3138	220 pF Cap 50V 10% Cerm SMT 0805
9	C12,C16,C23,C24,C62,C68, C123,C124,C151	.022J	56-0008	.022 uF Cap 50V 5% Poly Film 223J ammo
18	C13,C36,C37,C49,C51,C52, C53,C57,C71,C100,C129, C154,C168,C169,C170,C184, C185,C193	10NPMEE1	60-0051-01	10 uF Cap 16V -20/+20% Elect., NP T&R
1	C14	.39J	56-0040	.39 uF Cap 50V 5% Stacked Metal Pet 394J ammo
3	C15,C17,C19	.10J	56-0012	.10 uF Cap 50V 5% Stacked Metal Pet 104J ammo
2	C18,C20	470PK500D	62-0071	470 pF Cap 500V 10% Ceramic Disc
5	C22,C25,C69,C143,C183	.047J	56-0010	.047 uF Cap 50V 5% Stacked Metal Pet 473J ammo
4	C26,C39,C142,C155	120PKD1	62-0002	120 pF Cap 50V 10% Ceramic Disc T&R
9	C29,C30,C32,C137,C138, C139,C144,C145,C146	33S63E	60-0324	33 uF Cap 63V Alum, Rad
10	C31,C77,C97,C141,C149, C172,C178,C192,C208,C244	10ME1	60-0049-01	10 uF Cap 16V -20/+20% Elect., -D Ammo
2	C33,C232	4.7ME1	60-0048-01	4.7 uF Cap 16V -20/+20% Elect., T&R
1	C34	1LLM50E1	60-0045-01	1.0 uF Cap 50V 20% Elect., LL T&R
5	C41,C188,C189,C190,C191	.47J	56-0016	.47 uF Cap 50V 5% Stacked Metal Pet 474J ammo
1	C42	2.2S50E	60-0072	2.2 uF Cap 50V -20/+80% Elect., -S
3	C47,C58,C250	15PJJD7	62-3128	15 pF Cap 50V 5% Cerm SMT 0805
2	C54,C76	.0068J	56-0005	.0068 uF Cap 50V 5% Poly Film 682J ammo
2	C55,C73	25PJJD1	62-0001	25 pF Cap 50V 5% Ceramic Disc T&R
1	C59	50PJJD1	62-0008	50 pF Cap 50V 5% Ceramic Disc T&R
1	C74	470PKD7	62-3133	470 pF Cap 50V 10% Cerm SMT 0805
4	C78,C80,C92,C101	.0010J	56-0000	.0010 uF Cap 50V 5% Poly Film 102J ammo
8	C83,C93,C95,C96,C109,	.010J	56-0006	.010 uF Cap 50V 5% Poly Film 103J ammo

DOD Software
 RP-20 MAIN BOARD
 055308A0.000
 Bill Of Materials
 Quan Reference

Revised: July 22, 1997
 Revision: A0
 July 30, 1997 15:11:34
 Part SYMAN Description

Page

Quan	Part	SYMAN	Description
	C126,C148,C150		
2	C84,C94	.0027J 56-0027	.0027 uF Cap 50V 5% Poly Film 272J ammo
2	C85,C98	150PMD1 62-0031	150 pF Cap 50V 20% Ceramic Disc T&R
6	C90,C113,C120,C131,C140,C147	120PJD7 62-3135	120 pF Cap 50V 5% Cerm SMT 0805
1	C102	47PJD7 62-3132	47 pF Cap 50V 5% Cerm SMT 0805
1	C107	.0018J 56-0026	.0018 uF Cap 50V 5% Poly Film 182J ammo
3	C125,C196,C197	.0022J 56-0002	.0022 uF Cap 50V 5% Poly Film 222J ammo
14	C152,C153,C160,C163,C164,C165,C166,C167,C171,C173,C174,C177,C179,C182	100S50E 60-0068	100 uF Cap 50V -20/+80% Elect
8	C175,C176,C180,C181,C194,C195,C200,C201	470M25E 60-0058	470 uF Cap 25V -20/+20% Elect
4	C199,C202,C205,C206	.10KD7 62-3139	.10 uF Cap 50V 20% Cerm SMT 0805
1	C216	4700ME4 60-0062	4700 uF Cap 16V -20/+20% Elect-L
4	C219,C226,C236,C252	22PJD7 62-3134	22 pF Cap 50V 5% Cerm SMT 0805
3	C223,C224,C229	.047MA3 62-0067	0.047 uF Cap 50V 20% Axial Monolithic
2	D1,D8	LED702082 70-2082	Red Light Emitting Diode, T1 Encap, w/housing
20	D2,D3,D4,D5,D6,D7,D9,D10,D11,D12,D13,D15,D16,D17,D18,D31,D32,D43,D44,D45	1N4148R 70-0004	1N4148 Diode Silicon Switching, 75 Volts PIV, RADIAL
8	D14,D19,D20,D21,D38,D39,D40,D41	1N4001R 70-0000	1N4001 Silicon Rectifier, 1 Amp, 50 Volts PIV, RADIAL
14	D22,D23,D24,D25,D26,D27,D28,D29,D30,D33,D34,D35,D36,D37	1N4005R 70-0017	1N4005 1N4005,Silicon Rectifier, RADIAL
1	D42	1N5402 70-0100	1N5402 Silicon Rectifier, 3Amp, 200 PIV
1	H1	PA3156 00-0000	3 Pin Pad Pattern, Not a part, .156 spacing
1	H2	PA5156 00-0000	5 Pin Pad Pattern, Not a part, .156 spacing
1	H3	HDR2 32-1069	2 Pin Header, 0.1" spacing, Cut from 5 Pin Hdr
2	H4,H5	PA10/2MM 00-0000	10 Pin Pad Pattern, Not a part, 2MM Spacing
1	H6	PA13X2 00-0000	13X2 Pin Pad Pattern, Not a part
1	H7	HDR321083 32-1083	14 Pin Hdr, 7x2, 0.1" spacing, 0.025 pins, .375
1	HS1	HS704204 70-4204	Heatsink, 3 Regulator, Top
1	HS2	HS704205 70-4205	Heatsink, L-Shape Base
1	I1	INS704209 70-4209	Insulator, 3 Regulator Heatsink
1	J1	J320118 32-0118	1/4 Phone Jack, Hor. Mount, 1/2 Nose Thread Slimline
3	J2,J3,J4	J320119 32-0119	1/4 Phone Jack, Hor. Mount, Full Nose Thread Slimline
1	J5	J320099 32-0099	4 Pin Din JACK, Female PCB Mount, R/A Shielded U/M
2	J6,J7	J320116 32-0116	JACK, Shielded 5 pin DIN, PCB mount
1	JP1	SBRIDGE 00-0000	Jumper, solder bridge
12	L1,L2,L5,L6,L7,L8,L9,L10,L11,L17,L18,L19	FB260217 26-0217	Ferrite Bead, 2.5Kohms @70Mhz, SMT 0805
6	L3,L14,L15,L16,L20,L21	FB260219 26-0219	Ferrite Bead, 600 ohms @100Mhz, SMT 0805
1	L4	600UH-H 26-0196	600 uH Inductor
2	L12,L13	FB260215R 26-0215	Ferrite Bead, 70ohms @100Mhz, RADIAL
1	P1	100K402030 40-2030	100 K "W" 12mm, Rot Pot, 25mm D Shaft Hor
1	P2	100K402113 40-2113	100 K "D" 14mm, Rot Pot X2, 25mm D shaft horiz mt.
2	PA1,PA2	PA1 00-0000	1 Pin Pad Pattern, Not a part
1	PCB1	80-5308-A 80-5308-A	RP20 Valve Main PCB, RAW
1	Q1	LPT80A-V 70-2010	Photo Transistor, Vertical (LPT80-A)
4	Q2,Q3,Q8,Q9	2N5088 70-1007	2N5088 NPN, Transistor, T&R

DOD Software

Page

RP-20 MAIN BOARD
055308A0.000
Bill Of Materials
Quan Reference

Revised: July 22, 1997

Revision: A0

July 30, 1997 15:11:34
Part SYMAN Description

Quan	Reference	Part	SYMAN	Description
2	Q4,Q6	2N6714	70-1155	2N6714 NPN, Transistor
2	Q5,Q7	2N6726	70-1156	2N6726 PNP, Transistor
18	Q10,Q11,Q12,Q13,Q14,Q15, Q16,Q17,Q18,Q19,Q20,Q21, Q22,Q23,Q24,Q25,Q26,Q27	2N4124	70-1009	2N4124 NPN, Gen. Purp. Amplifier/Switching Xstr T&R
58	R1,R5,R15,R16,R19,R26, R27,R31,R33,R51,R53,R73, R88,R90,R103,R111,R113, R114,R117,R118,R121,R134, R137,R138,R143,R144,R156, R157,R168,R176,R178,R180, R185,R188,R220,R235,R240, R241,R243,R320,R322,R323, R324,R326,R327,R328,R329, R330,R331,R336,R337,R338, R339,R340,R344,R345,R347, R349	10K-7	50-1503	10 KOhm Resistor 5% 1/10 Watt CF, SMT 0805
16	R2,R6,R14,R44,R47,R48, R55,R72,R74,R96,R108, R115,R127,R128,R195,R313	1M-7	50-1506	1 MOhm Resistor 5% 1/10 Watt CF, SMT 0805
3	R3,R7,R104	62K-7	50-1501	62 KOhm Resistor 5% 1/10 Watt CF, SMT 0805
19	R4,R58,R105,R123,R140, R204,R255,R259,R264,R269, R272,R276,R280,R293,R297, R301,R305,R308,R333	3.3K-7	50-1525	3.3 KOhm Resistor 5% 1/10 Watt CF, SMT 0805
9	R8,R11,R80,R81,R85,R99, R154,R206,R316	0-7	50-1531	0 Ohm Resistor 5% 1/10 Watt CF, SMT 0805
11	R9,R10,R21,R70,R133,R214, R222,C243,R247,R252,R317	OMIT	00-0000	This part has been omitted
23	R12,R22,R40,R61,R63,R66, R82,R83,R109,R124,R125, R126,R146,R153,R171,R172, R184,R193,R201,R205,R219, R245,R350	2K-7	50-1508	2 KOhm Resistor 5% 1/10 Watt CF, SMT 0805
26	R13,R18,R256,R257,R260, R261,R265,R266,R273,R274, R277,R278,R281,R282,R283, R285,R294,R295,R298,R299, R302,R303,R306,R307,R309, R312	680-7	50-1511	680 Ohm Resistor 5% 1/10 Watt CF, SMT 0805
28	R17,R20,R24,R25,R42,R56, R76,R100,R110,R151,R152, R179,R187,R190,R209,R254, R258,R263,R267,R271,R275, R279,R287,R292,R296,R300, R304,R334	100K-7	50-1504	100 KOhm Resistor 5% 1/10 Watt CF, SMT 0805
19	R23,R28,R54,R64,R65,R75, R86,R91,R95,R132,R166, R208,R221,R262,R268,R288, R289,R290,R291	20K-7	50-1507	20 KOhm Resistor 5% 1/10 Watt CF, SMT 0805
7	R29,R97,R98,R158,R167, R175,R181	33K-7	50-1512	33 KOhm Resistor 5% 1/10 Watt CF, SMT 0805

DOD Software
RP-20 MAIN BOARD

Revised: July 22, 1997

Page

055308A0.000

Revision: A0

Bill Of Materials

July 30, 1997 15:11:34

Quan	Reference	Part	SYMAN	Description
10	R30,R41,R59,R67,R119, R142,R149,R155,R161,R197	470K-7	50-1523	470 KOhm Resistor 5% 1/10 Watt CF, SMT 0805
11	R32,R35,R46,R69,R71,R89, R101,R129,R170,R321,R351	4.7K-7	50-1509	4.7 KOhm Resistor 5% 1/10 Watt CF, SMT 0805
6	R34,R43,R107,R183,R186, R189	220K-7	50-1514	220 KOhm Resistor 5% 1/10 Watt CF, SMT 0805
10	R36,R112,R116,R120,R135, R136,R141,R173,R194,R216	6.8K-7	50-1513	6.8 KOhm Resistor 5% 1/10 Watt CF, SMT 0805
2	R37,R79	22-7	50-1532	22 Ohm Resistor 5% 1/10 Watt CF, SMT 0805
1	R38	22M	50-0307	22 MOhm Resistor 5% 1/4 Watt Carbon Film
2	R39,R335	330-7	50-1517	330 Ohm Resistor 5% 1/10 Watt CF, SMT 0805
18	R45,R50,R60,R62,R78,R84, R87,R106,R150,R164,R215, R218,R223,R318,R319,R341, R342,R353	1K-7	50-1505	1 KOhm Resistor 5% 1/10 Watt CF, SMT 0805
2	R49,R52	330K-7	50-1519	330 KOhm Resistor 5% 1/10 Watt CF, SMT 0805
7	R57,R122,R139,R231,R232, R233,R234	51-7	50-1524	51 Ohm Resistor 5% 1/4 Watt CF, SMT 0805
3	R68,R93,R177	15K-7	50-1516	15 KOhm Resistor 5% 1/10 Watt CF, SMT 0805
11	R77,R92,R102,R130,R131, R174,R192,R200,R207,R213, R225	47K-7	50-1502	47 KOhm Resistor 5% 1/10 Watt CF, SMT 0805
4	R94,R145,R182,R196	22K-7	50-1522	22 KOhm Resistor 5% 1/10 Watt CF, SMT 0805
1	R147	470-7	50-1518	470 Ohm Resistor 5% 1/10 Watt CF, SMT 0805
16	R148,R159,R162,R169,R227, R228,R242,R244,R248,R250, R253,R270,R284,R286,R325, R354	10-7	50-1500	10 Ohm Resistor 5% 1/10 Watt CF, SMT 0805
11	R160,R163,R236,R237,R238, R239,R249,R314,R315,R343, R346	100-7	50-1515	100 Ohm Resistor 5% 1/10 Watt CF, SMT 0805
1	R165	3.9M-7	50-1537	3.9 MOhm Resistor 5% 1/10 Watt CF, SMT 0805
1	R191	4.7K	50-0015	4.7 KOhm Resistor 5% 1/4 Watt Carbon Film
4	R198,R199,R202,R203	10.0K 1%-7	52-4500	10.0 KOhm Resistor 1% 1/10 Watt MF, SMT 0805
4	R210,R211,R212,R332	27K-7	50-1527	27 KOhm Resistor 5% 1/10 Watt CF, SMT 0805
1	R217	7.5K-7	50-1521	7.5 KOhm Resistor 5% 1/10 Watt CF, SMT 0805
8	R224,R226,R229,R230,R310, R311,R348,R352	200-7	50-1510	200 Ohm Resistor 5% 1/10 Watt CF, SMT 0805
1	R246	39K-7	50-1528	39 KOhm Resistor 5% 1/10 Watt CF, SMT 0805
1	R251	47 2W	50-2166	47 Ohm Resistor 5% 2 Watt Carbon Film
1	RC1	RC321214	32-1214	26 Pin Ribbon Cable Conn, .1 spacing, 13X2
2	RCH1,RCH2	RCH10079	32-1221	10 Pin Ribbon Cable, Holder, 2mm spacing
1	S61	DIP32S	70-3017	32 Pin Dip Socket
2	SR1,SR2	SR280058	28-0058	Screw, 6-32 x 3/8", Pozi, Pan, Black
2	SR3,SR4	SR280059	28-0059	Screw, 6-32 x 1/4", Pozi, Pan, Black
4	SS1,SS2,SS3,SS4	SS280897	28-0897	Swage Standoff, 0.187" Round x 0.125"H, 4-40
4	SS5,SS6,SS7,SS8	SS280902	28-0902	Swage Standoff, 0.187" Round x 0.250"H, 4-40
1	TP1	TESTP	00-0000	Test point, Standard
19	U1,U2,U3,U11,U13,U14,U16, U18,U20,U21,U23,U24,U25, U26,U28,U29,U30,U32,U33	LF353/SM	72-4032	LF353M Dual Op-Amp, SMT
2	U4,U5	ADS1286	72-1420	CONVERTER, 12-Bit Serial A to D, SMT

DOD Software

RP-20 MAIN BOARD

055308A0.000

Revised: July 22, 1997

Revision: A0

Page

Bill Of Materials
Quan Reference

July 30, 1997 15:11:34
Part SYMAN Description

Quan	Reference	Part	SYMAN	Description
4	U6,U9,U10,U15	NJM4560/SM	72-4233	NJM4560 Dual Op-Amp, SMT SOIC
1	U7	THAT2252	72-4056	THAT2252 RMS Level Detector
3	U8,U19,U22	2159	72-4262	VCA,THAT 2159 (DOD & Digitech)
1	U12	4053/SM	72-0087	74HC4053 Triple 2 to 1 Analog Multiplexer, SMT
2	U17,U37	CD4052DA/S	72-0079	Dual 4-CH MUX, SOIC, SMT
2	U27,U43	LM1972/SM	72-4038	LM1972 2-Channel Audio Attenuator w/Mute, SMT
1	U31	79L05	70-4127	79L05 -5 Volt 100 mA Voltage Regulator TO-92
1	U34	LM1973A/SM	72-4036	LM1973 3-Channel 76dB Audio Attenuator w/Mute (SMT)
1	U35	7912-H	70-4017	7912 -12 Volt 1 Amp Voltage Regulator TO-220 HORIZ
1	U36	7812-H	70-4013	7812 +12 Volt 1 Amp Voltage Regulator TO-220 HORIZ
6	U38,U41,U49,U50,U58,U59	74HC574/SM	72-1263	Octal D-Type Edge Triggered Flip-Flops SMT
1	U39	LA10502	54-0351	8 Bit R-2R Ladder, 5.00 kOhm 1% Thick Film
1	U40	7805-H	70-4014	7805 +5 Volt 1 Amp Voltage Regulator TO-220 HORIZ
1	U42	CS4327	72-3020	CS4327, 20 Bit Stereo, 101dB DAC, SMT
1	U44	CS5335	72-3021	CS5335, 20 Bit Stereo, 105dB ADC, SMT
1	U45	78L05	70-4012	78L05 +5 Volt 100 mA Voltage Regulator TO-92
1	U46	TMS57070	72-3042	TMS57070 in QFP100 SPECIAL FOOTPRINT, SMT
1	U47	74HC139/SM	72-5420	Dual 2 Line to 4 Line Decoder/Demultiplexer, SMT
1	U48	74AC74/SM	72-5425	74AC74 Dual D-Type Pos Edge Trig Flip-Flop, SMT
1	U51	SDISCI1_10	72-3178	SDISCI1 W/I's Interface in QFP100 SPECIAL FOOTPRINT, SMT
1	U52	MC34064P	70-5004	MC34064 Undervoltage Sensing Circuit
2	U53,U54	74HC244A/S	72-1111	Octal Buffer-Line Driver W/3-State Outputs SMT
1	U55	6N138	70-2139	6N138 Opto-Isolator
2	U56,U57	256KX16-70	72-1419	DRAM, 256K x 16 70ns, SOJ, SMT
1	U60	74HC04/SM	72-1086	Hex Inverter 74HC04, SMT
1	U61	72-1423-04	72-1423-04	AT49F040-12JC 4 MEG Flash EEPROM,V1.00 (RP20)
1	U62	128KX8_SRA	72-5417	128K X 8 RAM Static, SMT
1	U63	74HC86/SM	72-1404	74HC86 Quad 2-Input XOR Gate, SMT
2	U64,U65	74HC138/SM	72-5419	3 Line to 8 Line Decoder/Demultiplexer, SMT
1	U66	Z8S180/S	72-4161	CPU Z8S180 Microprocessor, 20MHz (SMT)
1	W1	W360031	36-0031	Wire, 2 End, 5.50", White, 20AWG UL/CSA
4	WA1,WA2,WA3,WA4	WA280187	28-0187-A	Washer, for grounding J320119
1	X1	22.579MHZ-	76-0316	20.579 MHZ Crystal, Low Profile
1	X2	20.000MHZ-	76-0317	20.00 MHZ Crystal, Low Profile