

 Seymour Duncan®

OWNER'S MANUAL
for the
BASS 400 AMPS

 **Seymour Duncan®**

If you're like most musicians I know, the first thing you want to do is plug-in your new amp and start playing -the last thing you want to do is read an owner's manual. Go ahead and play the amp and see what it can do for you.

Once you've completed the "breaking in" experience, please read through this manual. The amp is designed to give you versatility from functional controls and switches. This manual will show you the easy way of getting a wide variety of great sounds just by properly setting up the amp.

Enjoy it. If you have any comments about the design of your amp, I'd like to hear from you. If you have any ideas for other related products, please write me at the address below.

Thank you.



Seymour Duncan

P.S. If you haven't mailed in your warranty card, please do it now. It may seem like a hassle, but it's the only way we have to verify warranty status of your amp.

Serial Number: _____

Owned by: _____

Date of purchase: _____

Store purchased from: _____



601 Pine Avenue
Santa Barbara, CA 93117 USA
(805) 964-9610, Cable: SEYDUNCAN

WARNINGS:

- Make all speaker connections before plugging unit in.
- Do not disconnect the speaker(s) while the amp is turned on.
- Do not, in any way, restrict air movement around heatsink or cooling vents.
- Do not test the amplifier's operation by touching the tip of the input cable with your finger. This is a very wide bandwidth amp and the extreme amount of radio frequency energy caused by doing this can cause damage to the amp and your speaker system.
- Do not expose to rain or moisture.

Unpacking

Inspect your bass amp for hidden damage that may have occurred in transit. Your amp was inspected and sound tested before shipment from the factory.

All claims for shipping damage must be made by the receiver. Save your box and packing material for evidence of damage if it has occurred.

Packing Materials

The original box and packing materials are specially designed to protect your amp during shipment. **SAVE ALL PACKING MATERIALS.** In the unlikely event that your amp needs to be returned to the factory, the original box and packing material will be necessary for shipment. These are carrier approved packing materials and they will insure safe transit back to the factory.

FRONT PANEL CONTROLS

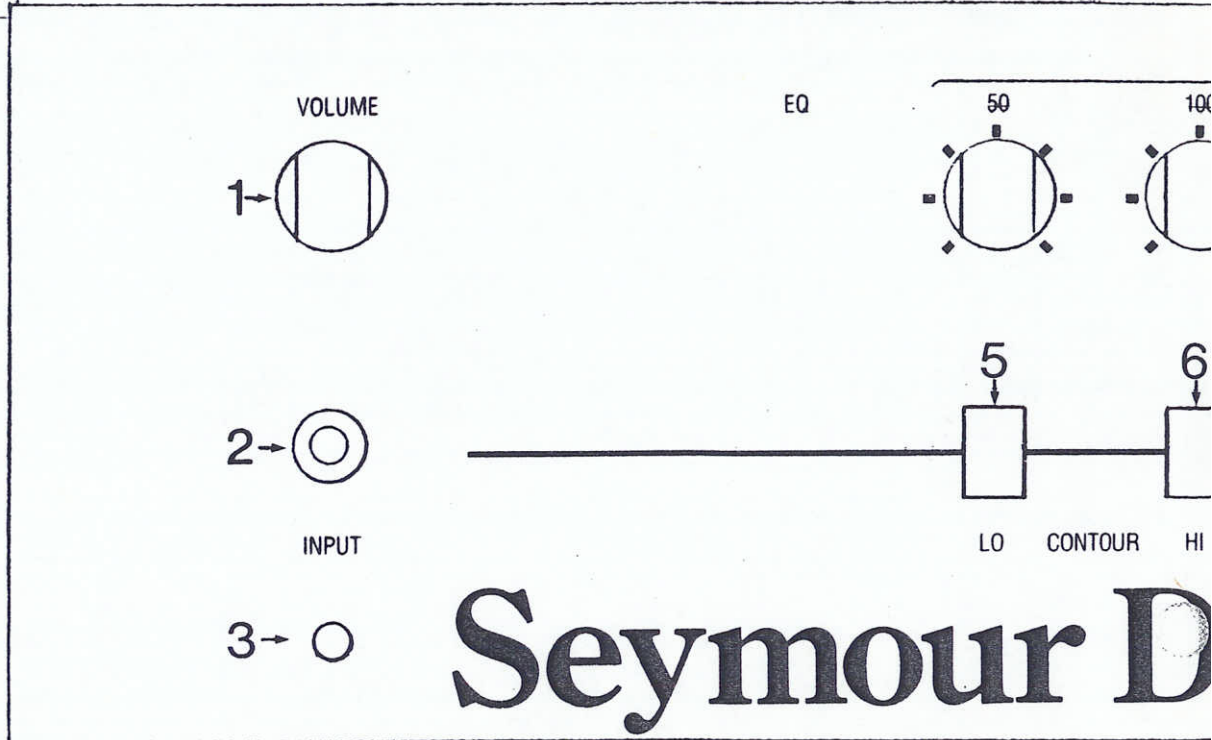

1. **VOLUME:** This control sends the signal volume from the preamp to the power amplifier. Turning the knob clockwise increases volume.
2. **BASS INPUT:** Plug your bass in here. Input impedance is 1 meg ohm.
3. **POWER INDICATOR:** When your amp is on, this L.E.D. will glow. The Bass 400 uses an L.E.D. instead of a normal bulb because L.E.D.'s last up to 10 times longer.

4. **GRAPHIC EQUALIZER:** This is an active equalizer system that provides 15 db of boost and cut (total range is 30 db) per band. Each band of the E.Q. is independent. You can vary the individual bands as much as you want without affecting the range of the other E.Q. controls.

By combining the graphic equalizer with the low contour switch, it is possible to achieve 30 db of gain boost at very low frequencies. Because the power amp is easily capable of providing very low frequencies, there is a potential threat to damaging speaker systems through cone over-excursion.

Exercise caution when playing at high volume levels with large amounts of low frequency boost. When playing outdoors, it may prove beneficial to slightly cut low frequencies to provide more headroom and louder playing volume.

4

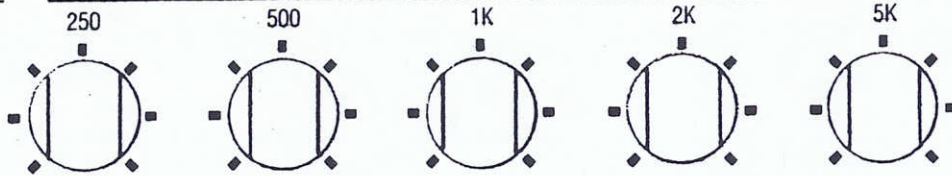

uncan BASS

BASS 400

5. **LOW FREQUENCY CONTOUR:** This switch provides 15 db of boost at 40 hz. It is especially useful when playing at lower volumes to create a "warm" sound.

6. **HIGH FREQUENCY CONTOUR:** This switch provides 15 db of boost at 4 khz. It is very useful for giving you extra presence or edge.

REAR PANEL CONTROLS

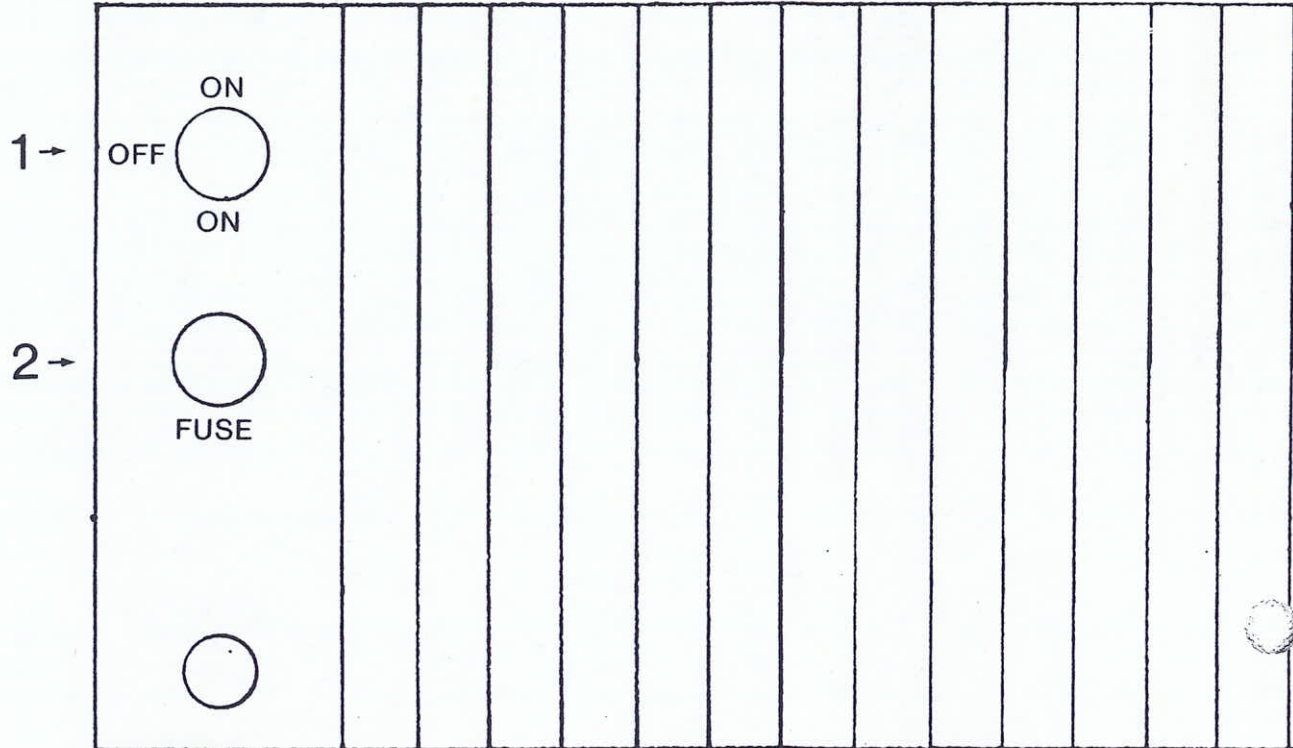

1. **ON/OFF/ON SWITCH:** This switch is designed to turn your amp on and to allow you to reverse the A.C. polarity. If you're picking up 60 hz. hum from the wall current, put the "ON" switch in the other "ON" position. If you're using other equipment like a P.A. and you get a shock when touching the microphone, place the "ON" switch in the other "ON" position to eliminate the shock. The middle position is "OFF".

2. **FUSE HOLDER:** The fuse is located in the cap of the fuse holder. If the fuse fails, it must be replaced with one that provides proper current protection or you will void the warranty. The proper fuse rating for the 110-120 v.a.c. Bass 400 amp is ABC-10.

Before removing the fuse cap, **UN-PLUG THE POWER CORD FROM THE WALL A.C. OUTLET.** After checking the fuse and replacing the fuse cap, you can plug the amp back into the wall.

To remove the fuse cap, simply grasp the cap with your fingers, push in, and turn counter-clockwise. To replace the cap, grasp the cap with your fingers, push in, and turn clockwise.

Fuses do not wear out; they do not deteriorate with age. Fuses are protection devices that prevent the electronics from damage if there is a serious electrical problem. If your amp repeatedly has fuse failures, call a service center.

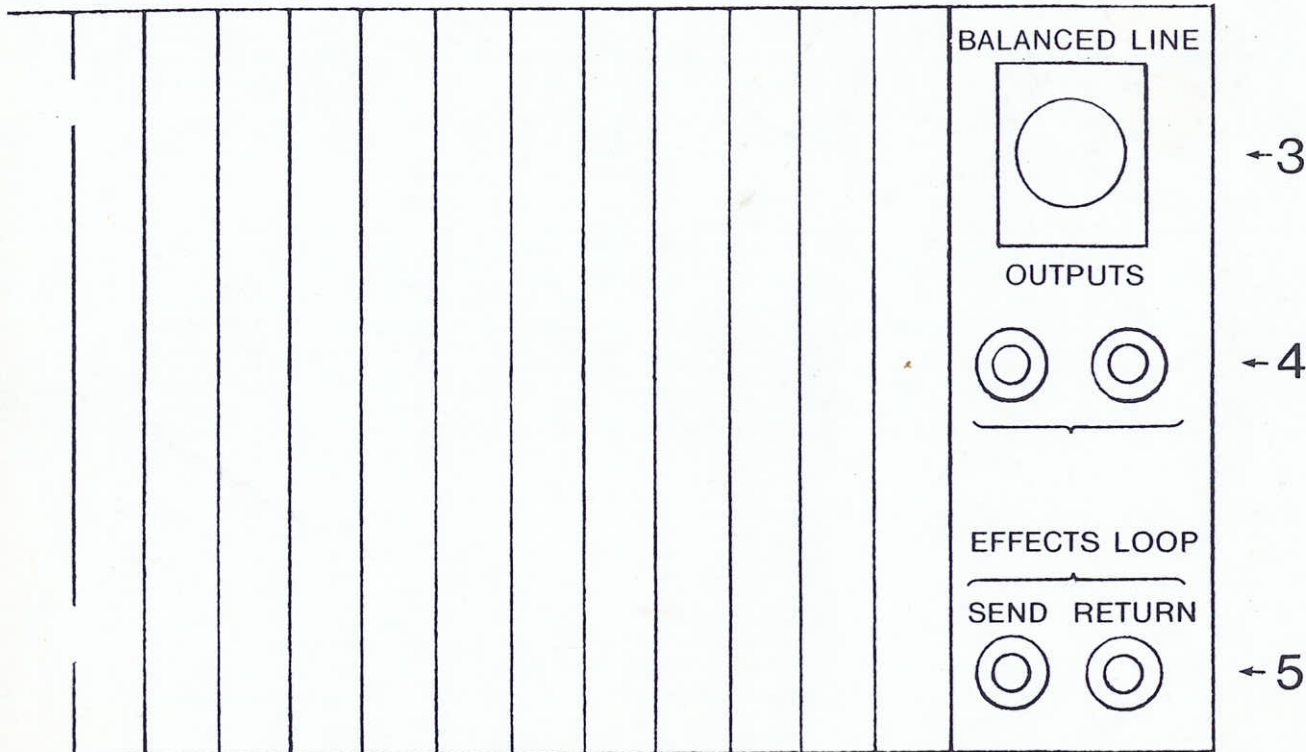

- BALANCED LINE OUTPUT:** Use this jack for patching the output signal of the amp directly into a mixer or tape recorder. This circuit is wired post-E.Q. so all tone settings will affect the outgoing signal. Output is one volt at full power.

The standard three pin XLR jack allows you to use a balanced line so you can run your cord for long distances with no signal loss and no hum.

Output impedance is 600 ohms.

- SPEAKER JACKS:** These output jacks accept standard 1/4" plugs. The jacks are wired in parallel. Optimum amp performance is realized with a 4 ohm speaker load. An 8 ohm load will yield less power. A 2 ohm will load yield more power but will cause the amp to run hotter. If you choose to run a 2 ohm speaker load, make sure there is adequate ventilation around the amp.

If you're only using one speaker, it doesn't make any difference which speaker jack you plug into. They are both "live".

- EFFECTS LOOP:** Use this circuit with your effects for the least amount of hiss. In older design amps, players had to plug their basses directly into effects and plug the effects into the input jacks on their amps. With the Bass 400, you can plug your bass into the Bass Input jack and run your effects through the Effects Loop.

"Effects Send" should be connected to the input of your effect using a normal guitar cable. "Effects Return" should be connected to the output of your effect using a normal guitar cable. You want the signal to come OUT of your amp INTO the effect and OUT of the effect INTO your amp.

Output impedance is 10k ohms.

TROUBLESHOOTING

The following table should enable you, with little or no knowledge of electronics, to isolate the cause of some problems you may experience with your amplifier and the steps required for repair. Most causes of impaired amplifier performance are due to minor problems or irregularities which can be easily corrected by you. However, if you cannot identify the cause of the problem using the table below, or if it indicates your amplifier to be defective and in need of repair, return the unit to an Authorized Seymour Duncan Service Center or call (805) 963-0676 for a Return Authorization number.

Symptom	Probable Cause	Remedy
Amp does not light up and come on when switch is "ON".	<ol style="list-style-type: none"> 1) Power not connected 2) Main fuse blown 	<ol style="list-style-type: none"> 1) Ensure power cord is plugged into operative power outlet 2) Check amp fuse; replace if blown with ABC-10. If it continues to blow, call service center.
Amp lights up, but no sound when power switch is "ON"	<ol style="list-style-type: none"> 1) Bad guitar cable 2) Bad speaker cable 3) Effects are hooked backwards in Effects Loop 4) Defective effects box 5) Blown speaker 6) Internal fuse blown 	<ol style="list-style-type: none"> 1) Replace cable 2) Replace cable 3) Reverse hook-up cables 4) Remove effects box 5) Hook up new speaker 6) Replace with ABC-10 fuse (see diagram). If it continues to blow, call service center
Distorted Sound	<ol style="list-style-type: none"> 1) Partially shorted speaker cable 2) Speaker impedance is below recommended value 3) Overboosted E.Q. settings 4) Defective or over-driven effect 5) Internal fuse blown 6) Defective speaker 7) Low battery (active pickups) 	<ol style="list-style-type: none"> 1) Replace cable 2) See manual for minimum load 3) Set E.Q. settings more moderately 4) Remove effect or reduce input sensitivity 5) Replace with ABC-10 fuse (see diagram). If it continues to blow, call service center 6) Replace speaker 7) Replace battery in pickups
Muddy Sound	<ol style="list-style-type: none"> 1) E.Q. settings set too high in lower frequency ranges 	<ol style="list-style-type: none"> 1) Reduce low frequency E.Q. settings
Buzzing Sound	<ol style="list-style-type: none"> 1) Ground Loop (in rack-mount installations) 2) Improperly wired instrument 3) Noisy A.C. line 	<ol style="list-style-type: none"> 1) Reverse ground or lift ground and re-ground the rack 3) Check instrument wiring 3) Reverse polarity of power switch

LET-110F

242007-SCM F
DRAWING NUMBER REV

4000 BASS

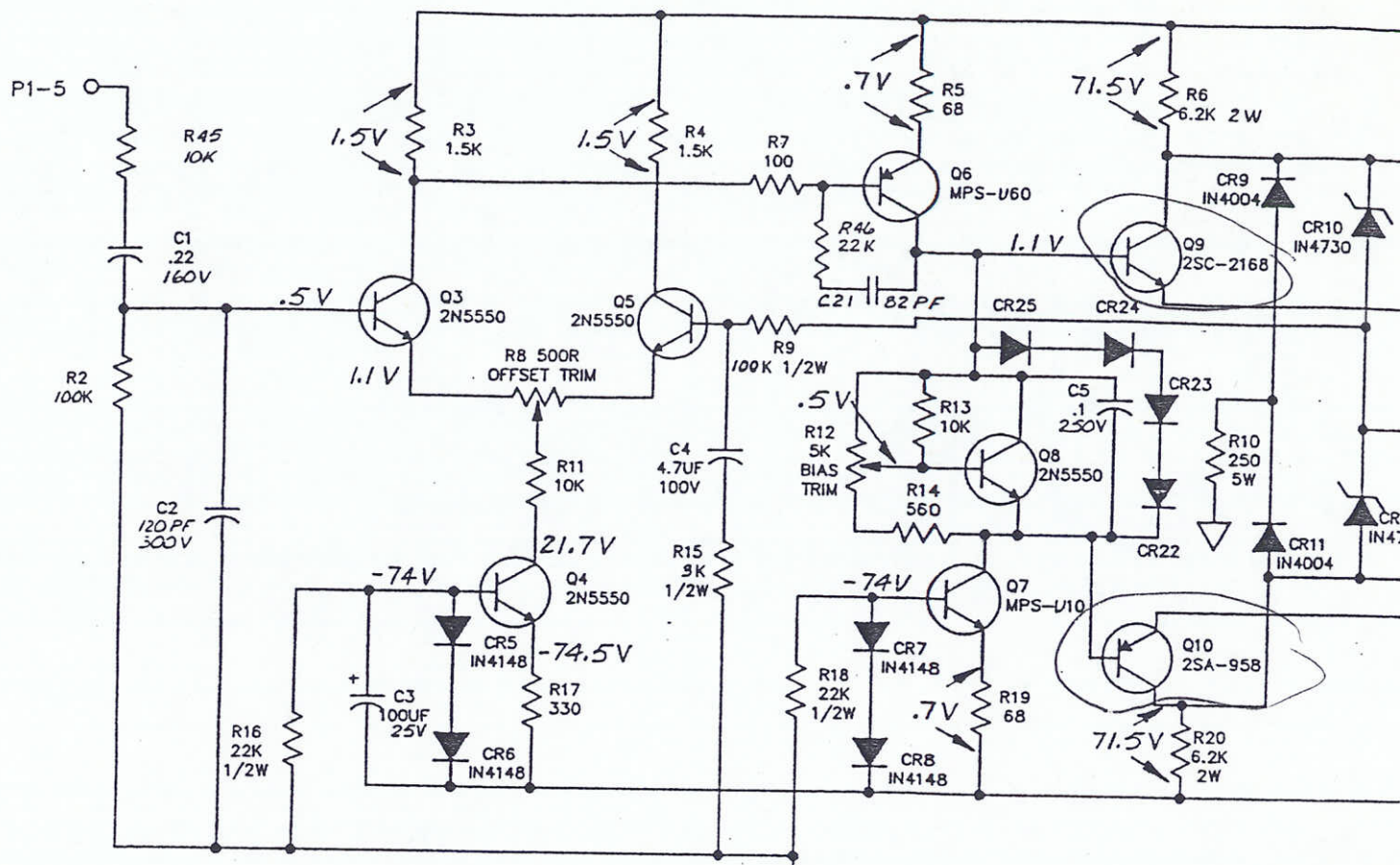

2SA958
2SC2168

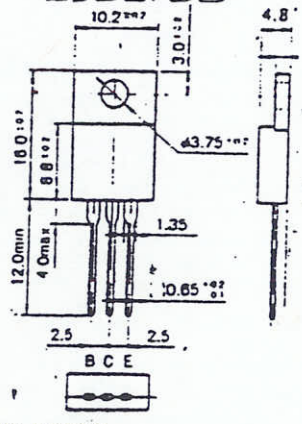

2SA1170, 7494
2SC2774, 3858

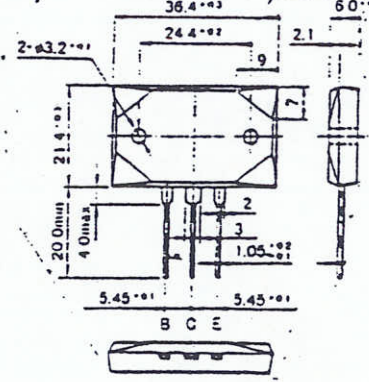

2N5550



CASE 29-02
TO-226AA
(TO-92)

Style 1:
Pin 1. Emitter
2. Base
3. Collector

NOTES

1. RESISTORS 1/4W UNLESS NOTED
2. CR-22, 23, 24, 25 ARE IN4004
3. Q8 2N5550 ON BOTTOM

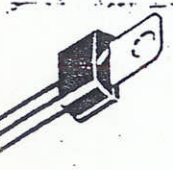

MPSU10, U60

STYLE 1:
PIN 1. EMITTER
2. BASE
3. COLLECTOR
(Collector Connected To Tab)

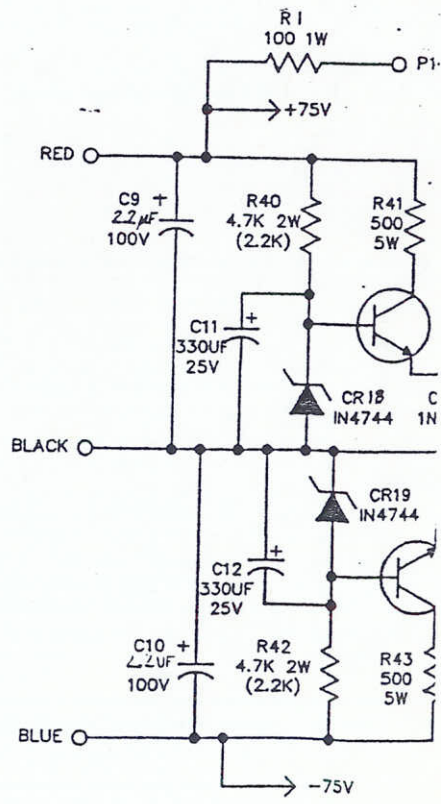

NOTES: UNLESS OTHERWISE SPECIFIED

RIG-11 10F

REVISIONS			
REV	DESCRIPTION	DATE	APPR

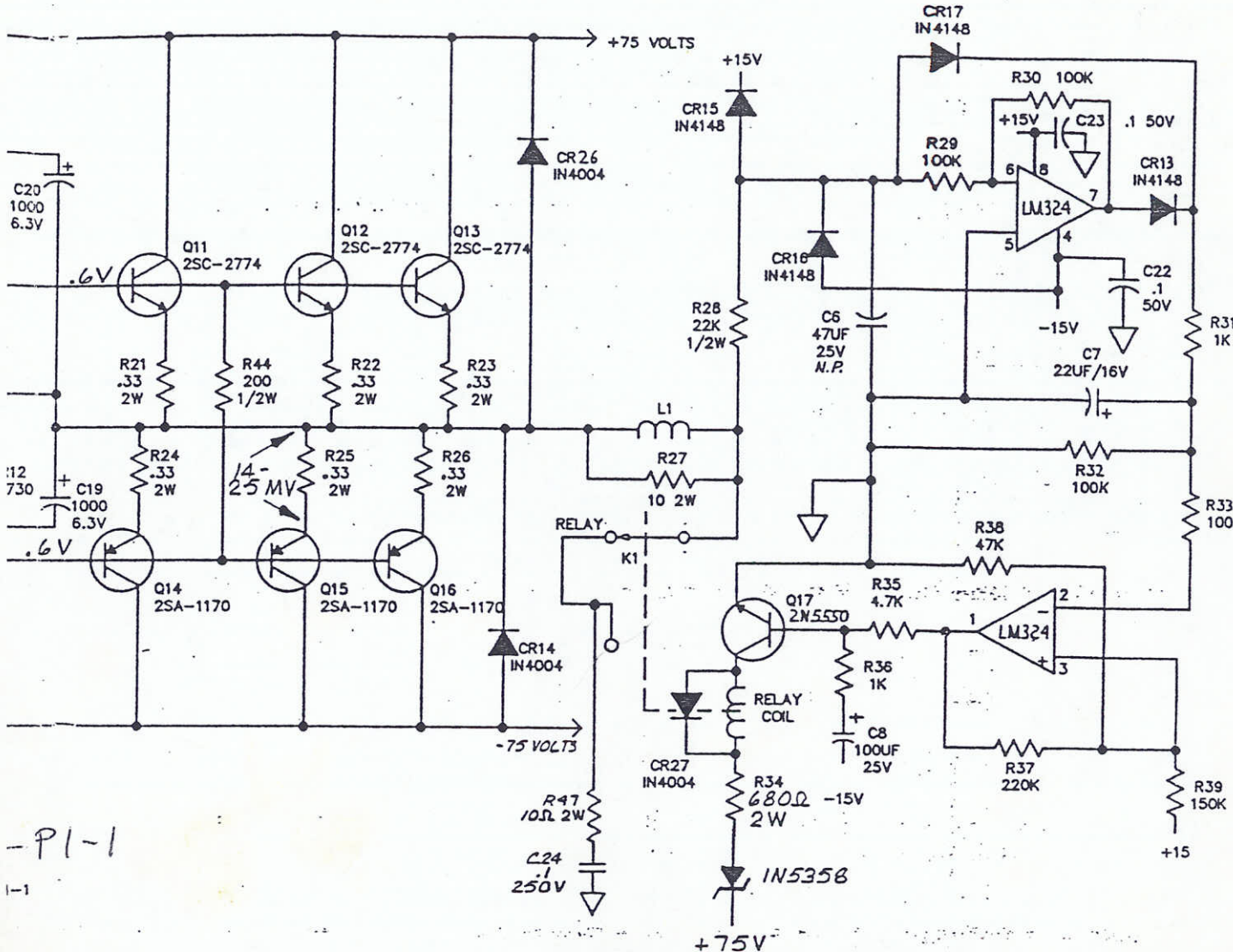

-P1-1
1-1

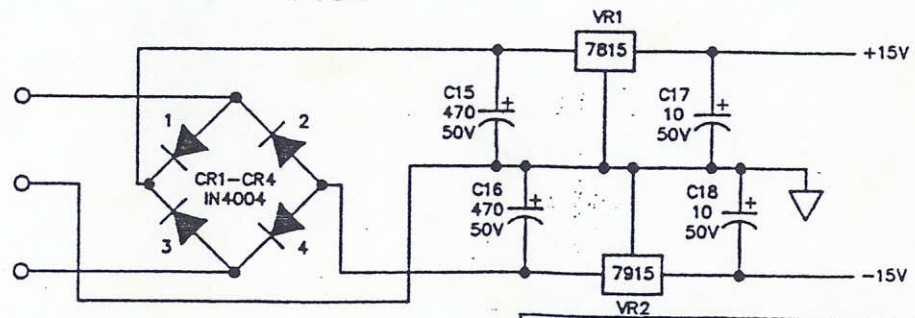
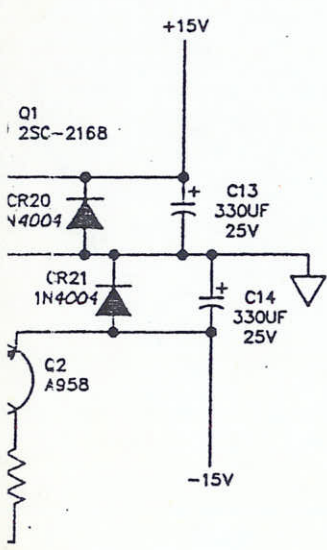

REV	DESCRIPTION	DATE	APPR
REV E	ECR MU 693 ADD COMP	10-11-8	K/B
REV D	UPDATE TITLE: ADD MODEL 4000	8-29-80	sm
REV D	CR13 CR20, 21 MAKE CORRECTIONS	10-20-87	K/B
REV C	ECR #BSA CHANGE R2, R15 H9	9-28-87	N/P
REV B	MECH. INTERF. C9,10 R4	2-13-87	
REV A	RELEASED	1-28-87	

REV F ECR T26/118 RELAY, DIODE

UNLESS OTHERWISE SPECIFIED INTERPRET DRAWING PER ANSI Y14 DIMENSIONS ARE IN INCHES AND APPLY AFTER PLATING BREAK SHARP EDGES

MATERIAL: _____

FINISH: _____

DATE: 1-29-87

DESIGN: MTR

CHECK: _____

PROJ: _____

ENG: _____

APPR: _____

USED ON: _____

THIS DOCUMENT CONTAINS PROPRIETARY INFORMATION IT MAY NOT BE REPRODUCED OR TRANSFERRED TO OTHER DOCUMENTS OR DISCLOSED TO OTHERS OR USED FOR MANUFACTURING OR ANY OTHER PURPOSE WITHOUT PRIOR WRITTEN PERMISSION

SEYMOUR DUNCAN

SCHEMATIC BASS AMP MONO POWER BLOCK MODEL 4000

SIZE: D DRAWING NUMBER: 242007-SCM REV: F

SCALE: NONE CUST. NO. SMD002 SHEET 1 OF 1

⇒ RIGHT

PROTECTION CIRCUIT

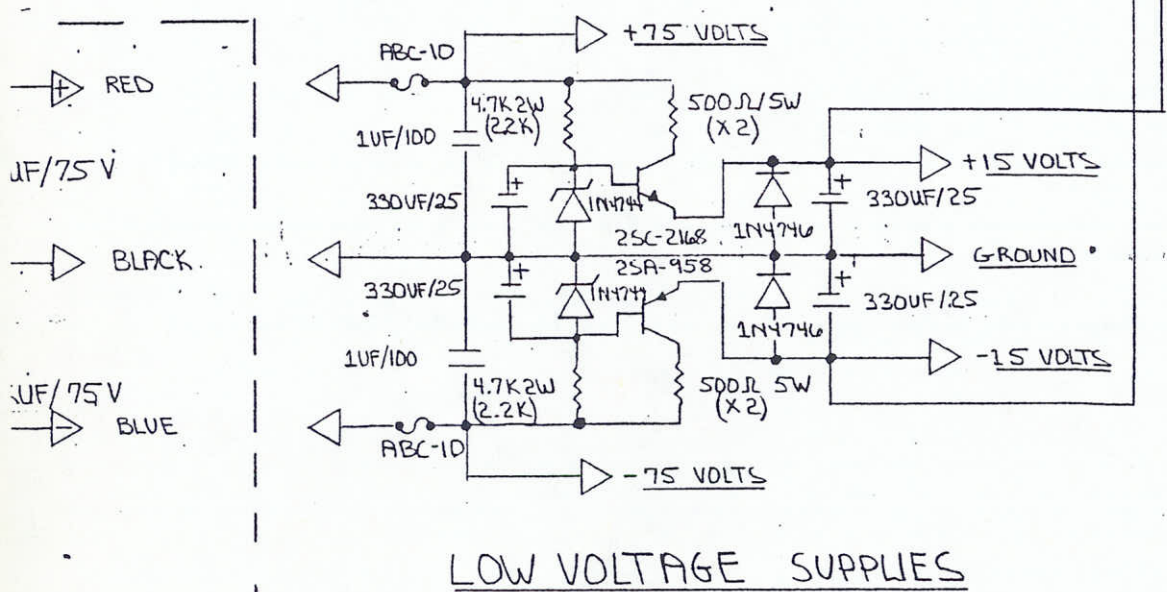
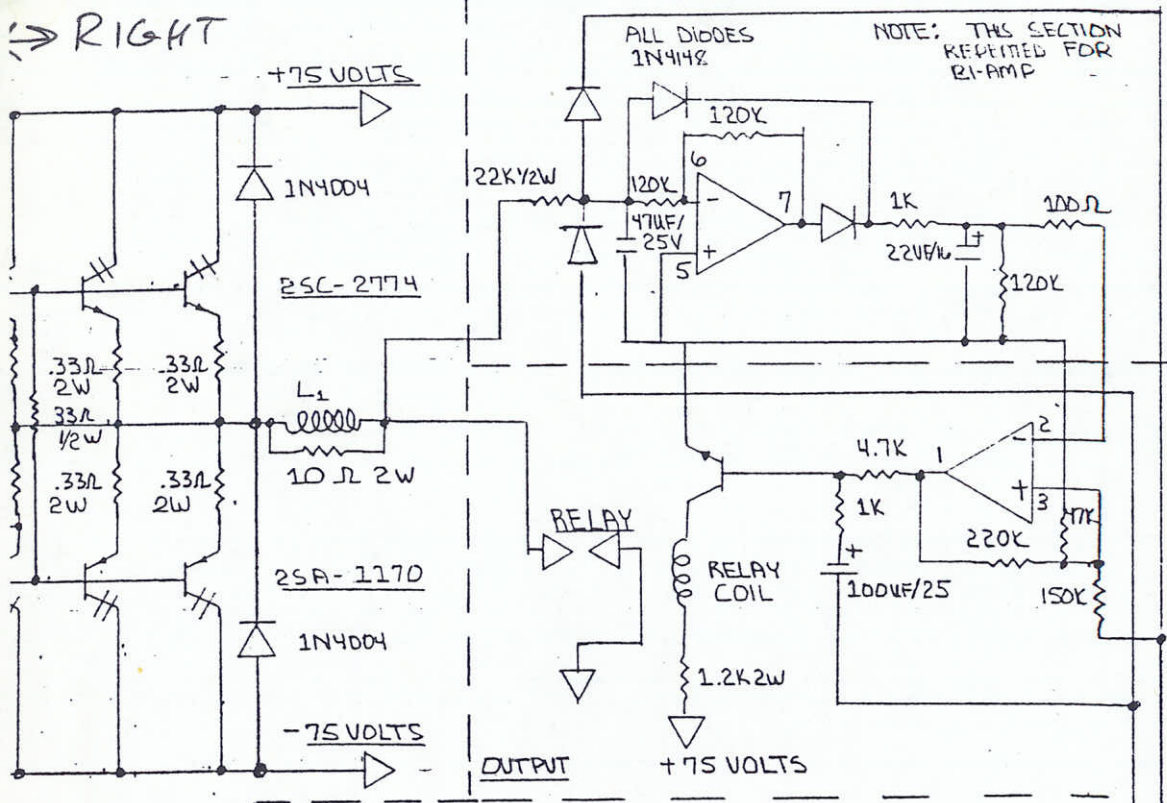

LOW VOLTAGE SUPPLIES

DRAWING NUMBER

BASS AMP POWER AMP BOARD & CHASSIS Schematic

BASS AMP POWER AMP PCB BOARD AND CHASSIS		
SCALE: NONE	APPROVED BY: <i>Rumbler</i> 1-15-85 RT	DRAWN BY BK
DATE: 1-15-85		REVISED
SCHEMATIC		
		DRAWING NUMBER