

CHECKING THE VERSION NUMBER

- Device Settings

Turn the VR knobs (pots) completely to the left (minimum).

- Hold down the [EDIT/EXIT] switch and [WRITE] switch and turn the POWER switch on.

Press the [FOOT 1] switch.

If the version number is Ver.1.01, the “b” (flat symbol) LED lights up, and “1” appears in the seven-segment LED.

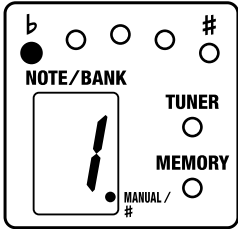

RESTORING THE FACTORY SETTINGS

- Hold down the [WRITE] switch and [◀] switch and turn the POWER switch on.

“F” appears in the seven-segment LED.

- Press the [WRITE] switch. The BANK LED flashes.
- Press the [WRITE] switch. The seven-segment LED and BANK LED flash, and the factory data is loaded.

The dot in the seven-segment portion lights, and Factory Reset is completed when the unit switches to Play mode.



Never turn off the power while factory data is being loaded.

TEST MODE

Items to Have On Hand

Oscilloscope (1)
Oscillator (1)
Monitor amps (2)
Noise meters (2)
FS-5U (2)
Open plug

Measuring Equipment Settings

Oscillator

Waveform: Rectangular wave
Frequency: 400 Hz
Output Level: 50 mVp-p

Oscilloscope

TIME/DIV : 0.5 msec
VOLTS/DIV : 0.2 V

Noise Meter

Filter: IHF-A (JIS-A)

Foot Switch (FS-5U)

POLARITY SW: Jack

Switching into Test Mode

- Device Settings

Turn all VR knobs (pots) completely to the left (minimum).

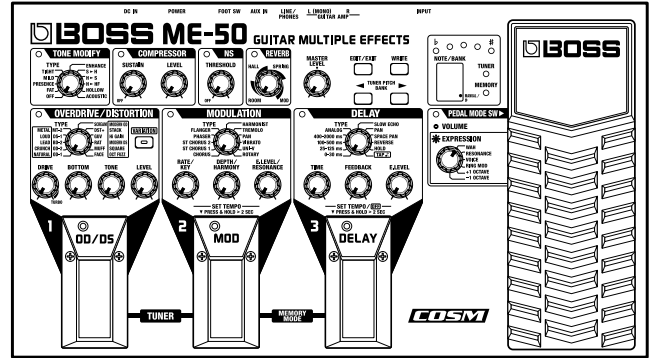

- Hold down the [EDIT/EXIT] switch and [WRITE] switch and turn the POWER switch on.

Test Categories

1. LED Full Lighting, EEPROM Check
2. LED Lighting Check
3. Key SW, Pedal SW Check
4. External SW Check
5. VR Check
6. EXP Pedal Check
7. DSP Check
8. D/A Circuitry Check
9. DRAM Check
10. INPUT A/D Check, AUX IN Check, Noise Check
11. EXP Pedal Adjustment

Test Details

Switch to Test mode.

- Device Settings

Turn all VR knobs (pots) completely to the left (minimum).

- Hold down the [EDIT/EXIT] switch and [WRITE] switch and turn the POWER switch on.

1. LED Full Lighting, EEPROM Check

- After the test is implemented, with data read from and written to the EEPROM, all of the LEDs light up.
- Confirm the following.

1. All LEDs are lit.
2. No LED goes off when the unit is subjected to shock.

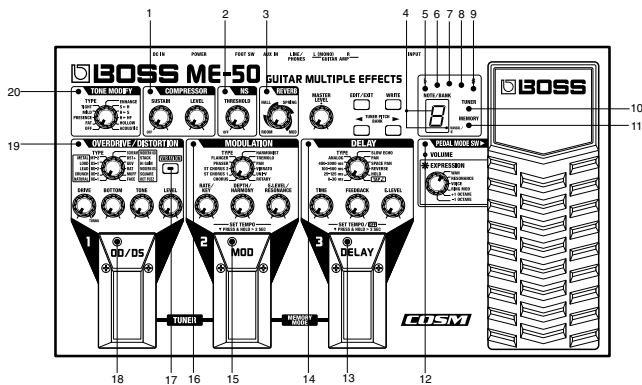

- With all LEDs lit, press the following switches to enable selection of the type of check to start.

Press the [FOOT 1] switch to proceed to the "Version Check."

Press the [FOOT 2] switch to proceed to "5. VR Check."

Press the [FOOT 3] switch to proceed to "6. EXP Pedal Check."

Press the [◀] switch to proceed to "7. DSP Check."

Press the [▶] switch to proceed to "11. EXP Pedal Adjustment."

- Version Check

Press the [FOOT 1] switch.

If the version number is Ver.1.01, the "b" (flat symbol) LED lights up, and "1" appears in the seven-segment LED.

After confirming the version, press the [▶] switch to proceed to the LED lighting check.

2. LED Lighting Check

- Confirm that the LEDs light up in sequence each the [WRITE] switch is pressed.

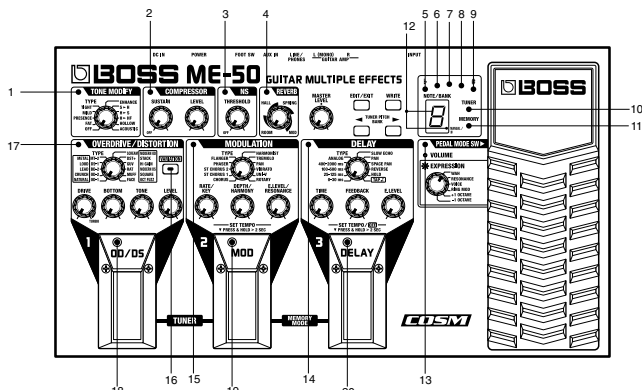

Sequence in Which LEDs Light Up

[TONE MODIFY]→[COMPRESSOR]→[NS]→[REVERB]→([b]→[#])
 →[TUNER]→[MEMORY]
 →[EACH SEGMENT OF 7-SEGMENT LED]→[PEDAL MODE SW]
 →[DELAY]→[MODULATION]
 →[OVERDRIVE/DISTORTION VARIATION]→[FOOT 1]→[FOOT 2]→[FOOT 3]
 →RETURN TO [TONE MODIFY]

- Press the [▶] switch to proceed to the next step.

Note: This will not advance the procedure to the next step unless the cycle has returned to [TONE MODIFY].

3. Key SW, Pedal SW Check

- Press the following switches in the indicated sequence.

[WRITE]→[▶]→[EDIT/EXIT]→[◀]→[TYPE VARIATION]→[FOOT 1]→[FOOT 2]→[FOOT 3]

Note: If the incorrect key is pressed inadvertently, the procedure does not advance to the next key unless the correct key is pressed twice.

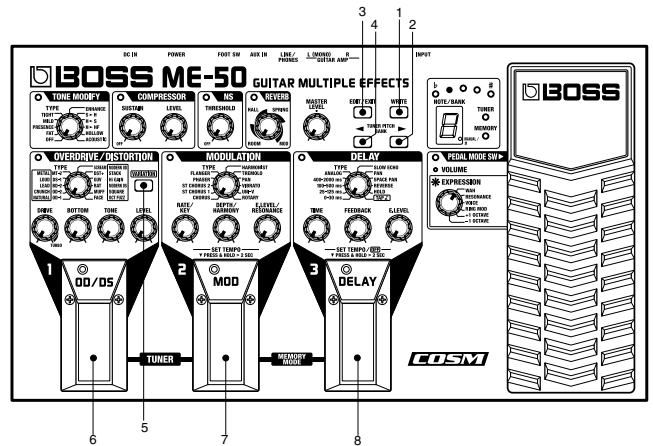

If no problem exists, the procedure automatically proceeds to the next step.

4. External SW Check

- Connect two FS-5U foot switches, one each to the [TONE MODIFY] and [COMP ON/OFF] jacks.

Set the FS-5U POLARITY switches at the jacks.

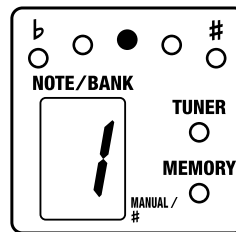

- Press the [TONE MODIFY] switch (FOOT SW = TIP).

If no problem exists, then "2" appears in the seven-segment display.

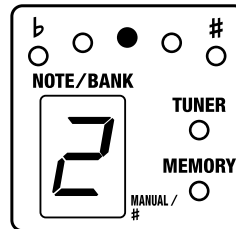

- Press the [COMP ON/OFF] switch (FOOT SW = RING).

If no problem exists, the procedure automatically proceeds to the next step.

5. VR Check

The dot in the seven-segment LED appears when the VR is not at the minimum position.

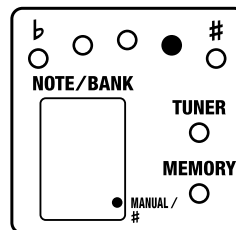

(1) Notched VR Check

- Rotate the following VRs in the indicated sequence.

[TONE MODIFY]→[OVERDRIVE/DISTORTION]→[MODULATION]→[DELAY]→[PEDAL MODE SW]

Note: The notched VRs turn in both directions (clockwise and counterclockwise).

Note: Confirm that what is displayed in the seven-segment LED changes with each notch position.

[TONE MODIFY], [OVERDRIVE/DISTORTION], [MODULATION], and [DELAY] = "0"--"A"

[PEDAL MODE SW] = "0"--"5"

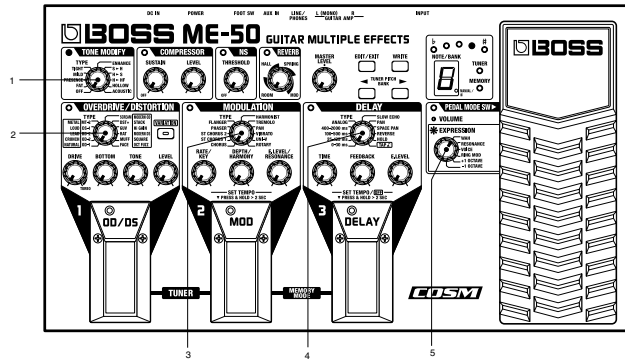

(2) Non-Notched VR Check

- Rotate the following VRs (pots) in the indicated sequence.
 [COMPRESSOR:SUSTAIN]→[COMPRESSOR:LEVEL]→[NS:THRESHOLD]→
 [REVERB]→[MASTER LEVEL]→[OVERDRIVE/DISTORTION:DRIVE]→
 [OVERDRIVE/DISTORTION:BOTTOM]→
 [OVERDRIVE/DISTORTION:TONE]→
 [OVERDRIVE/DISTORTION:LEVEL]→[MODULATION:RATE/KEY]→
 [MODULATION:DEPTH/HARMONY]→
 [MODULATION:E.LEVEL/RESONANCE]→
 [DELAY:TIME]→[DELAY:FEEDBACK]→[DELAY:E.LEVEL]

Note: Confirm that what is displayed in the seven-segment LED changes with each notch position.

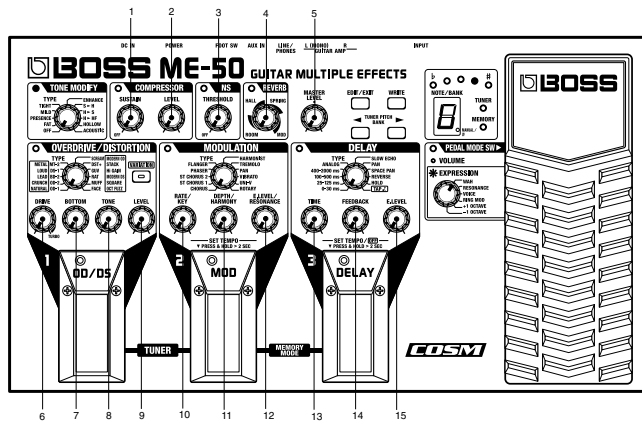
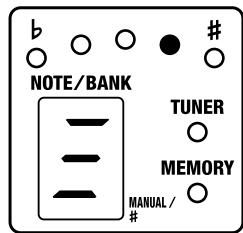
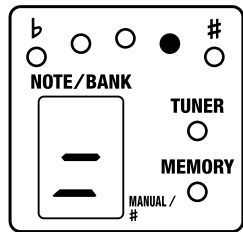
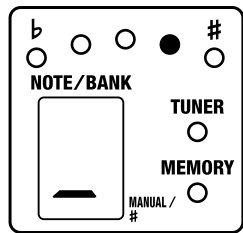

If no problem exists, the procedure automatically proceeds to the next step.

6. EXP Pedal Check

- Start with the expression pedal in the depressed position.
- Carry out the following operations in the indicated sequence.

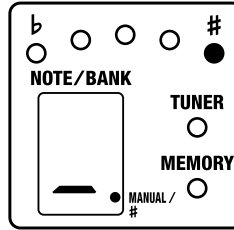

1. Raise the tip of the expression pedal until it is at its highest point.

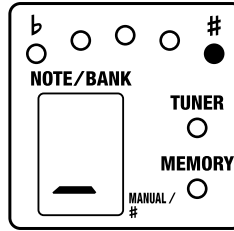

2. Lower the tip of the expression pedal until it is approximately at the midpoint.

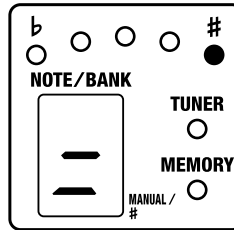

3. Once again, press down tip down completely so that the pedal is in the fully depressed position.

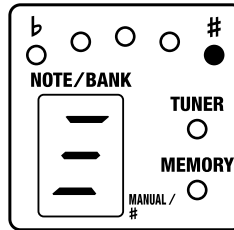

If no problem exists, the procedure automatically proceeds to the next step.

7. DSP Check

- The DSP check is performed automatically.
- If no problem exists, the procedure automatically proceeds to the next step.

8. D/A Circuitry Check

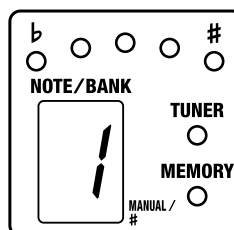

- Oscilloscope Settings: Ch1: 0.2 V/div; Ch2: 0.2 V/div; TIME: 0.5 ms/div
- Connect the cable only to the OUTPUT L(MONO) jack, then confirm that the waveform output by OUTPUT L(MONO) changes accordingly, as shown in the figures below.

[Mute Off]

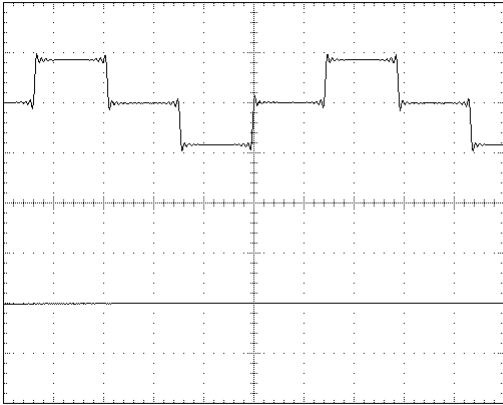

[Mute On]

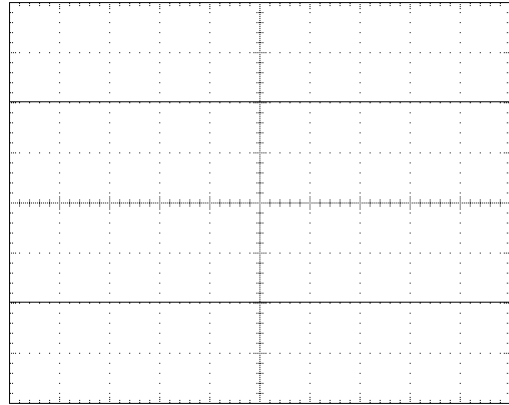

[Mute On]

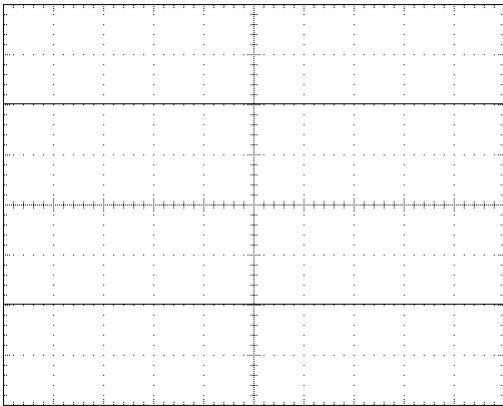

- Disconnect the cable from OUTPUT R, then confirm that the waveform output by OUTPUT L(MONO) changes accordingly, as shown in the figures below.

[Mute Off]

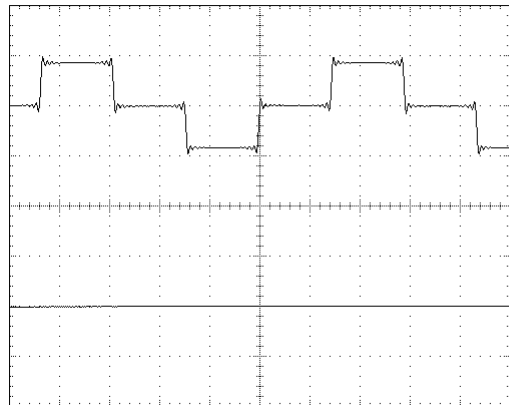

- Next, connect the cable to OUTPUT R, then confirm that the waveform output by OUTPUT R changes accordingly, as shown in the figures below.

[Mute Off]

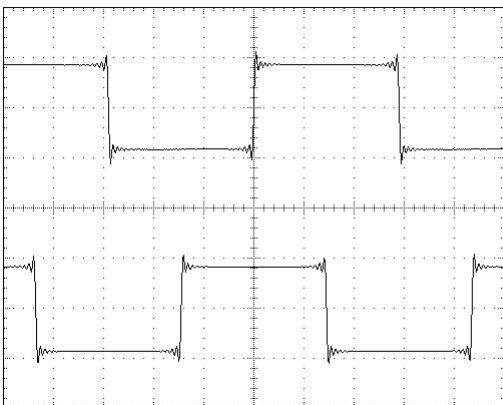

[Mute On]

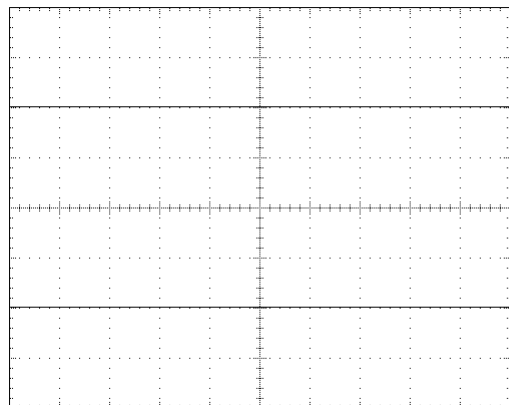

Reconnect the cable to OUTPUT R, then confirm that the waveform output by OUTPUT changes accordingly, as shown in the figures below.

[Mute Off]

- Confirm that the value for the waveform amplitude is between 380 and 540 (mVp-p).

[Mute On]

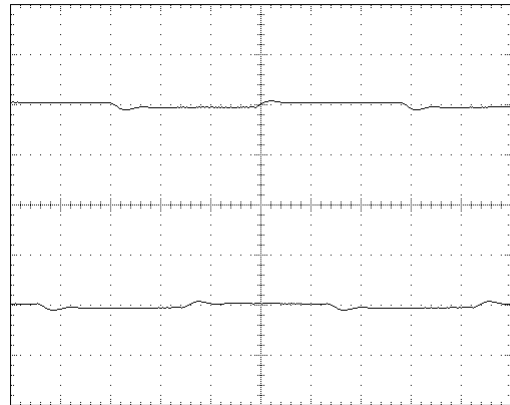
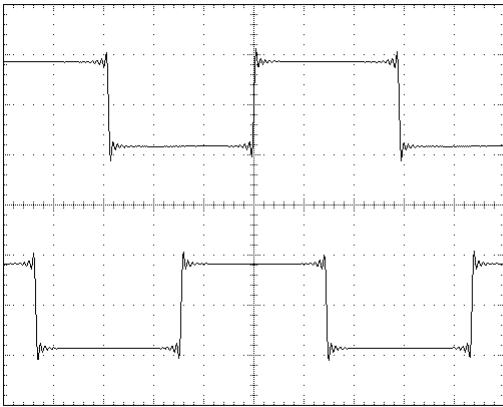

[Mute On]

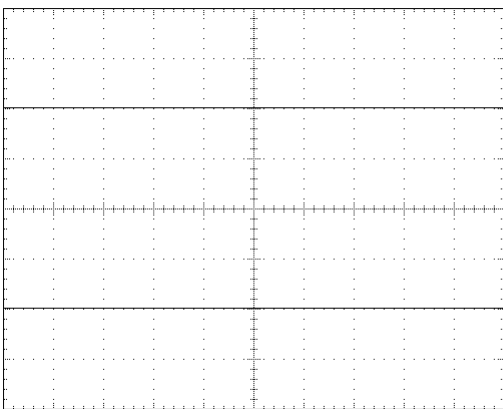

Press the [▶] switch to proceed to the next step.

9. DRAM Check

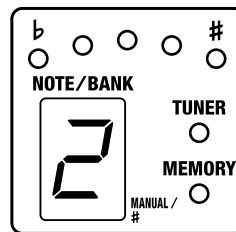

- Oscilloscope Settings: Ch1: 0.2 V/div; Ch2: 0.2 V/div; TIME: 0.5 ms/div
- Connect the cable only to the OUTPUT L(MONO) jack, then confirm that the waveform from OUTPUT is smooth, as shown in the figure below.
- Confirm that the value for the waveform amplitude is between 330 and 470 (mVp-p).

- Confirm that the LINE/PHONES waveform changes accordingly, as shown in the figures below.
- Confirm that the value for the waveform amplitude is between 600 and 850 (mVp-p).

[Mute Off]

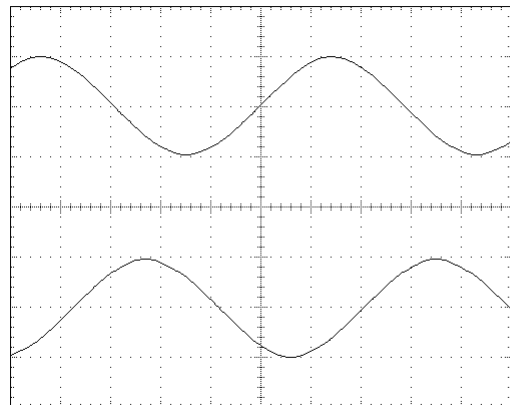
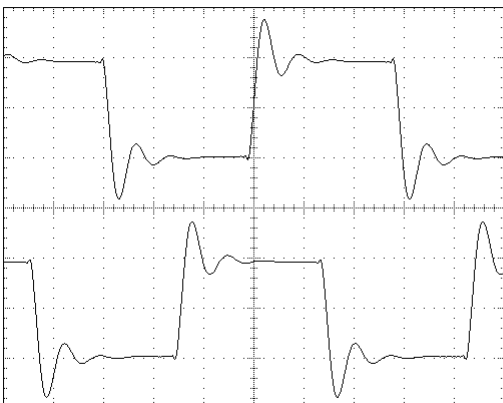

- Example of bad waveform: waveform is stepped

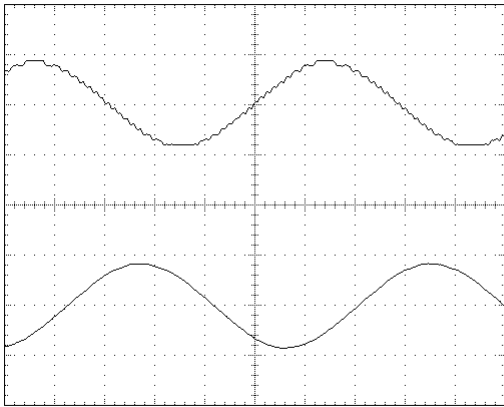

- Press the [▶] switch to proceed to the next step.

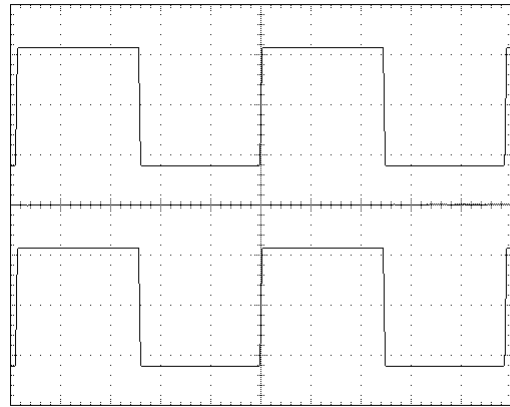

- Confirm that the LINE/PHONES waveform amplitude is between 290 and 410 (mVp-p).

10. INPUT A/D Check, AUX IN Check, Noise Check

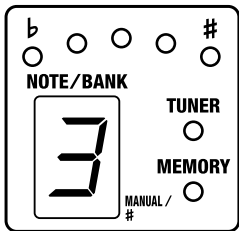

(1) INPUT A/D Check

Input a rectangular wave to the INPUT jack only, then check the waveform from OUTPUT.

- INPUT Signal: 400-Hz, 50-mVp-p square wave
- Oscilloscope Settings: Ch1: 0.2 V/div; Ch2: 0.2 V/div; TIME: 0.5 ms/div
- Confirm that the value for the waveform amplitude is between 320 and 460 (mVp-p).

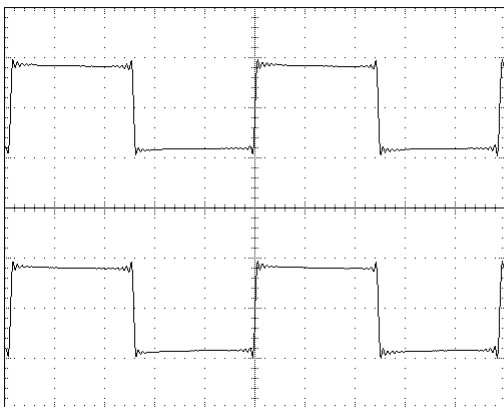

(2) AUX IN Check

Input a rectangular wave to the AUX IN jack only, then check the waveform from OUTPUT.

- INPUT Signal: 400-Hz, 200-mVp-p square wave
- Oscilloscope Settings: Ch1: 0.2 V/div; Ch2: 0.2 V/div; TIME: 0.5 ms/div
- Confirm that the value for the waveform amplitude is between 400 and 560 (mVp-p) GUITAR/AMP Jack.

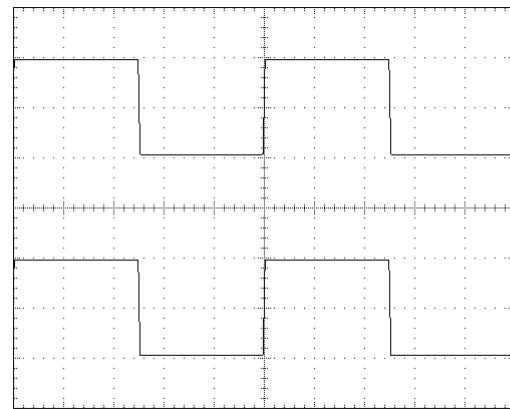

(3) INPUT-to-OUTPUT Noise Check

- Disconnect cable connected to INPUT and AUX IN.
- Listen to the noise and confirm the following.
 1. Noise level is -83.0 dBm IHF-A (JIS-A) or lower (both L and R).
 2. No abnormal sounds are mixed with the output sound.
 3. No abnormal sounds occur when the unit is subjected to shock.
- Press the [▶] switch to proceed to the next step.

11. EXP Pedal Adjustment

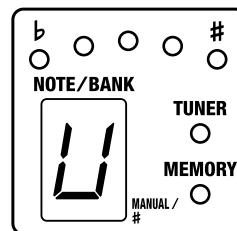
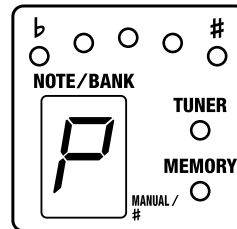

- Raise the unit's expression pedal completely, release the pedal, and press the [WRITE] switch.

NOTE

Note: Release the pedal when the pedal is fully raised, then press the [WRITE] switch.

If an error occurs, the green LED in the upper portion of the seven-segment LED display flashes.

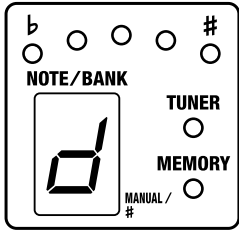

- Press the unit's expression pedal completely forward, release the pedal, and press the [WRITE] switch.

NOTE

Note: Release the pedal when the pedal is pressed down completely, then press the [WRITE] switch.

If an error occurs, the green LED in the upper portion of the seven-segment LED display flashes.

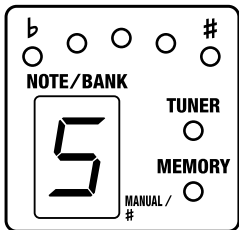

- Press the [◀] or [▶] switch to select "5," then press the [WRITE] switch.
- If no problem exists, the procedure automatically proceeds to Factory Reset.

Factory Reset

"F" appears in the seven-segment LED.

- Press the [WRITE] switch. The BANK LED flashes.
- Press the [WRITE] switch. The seven-segment LED and BANK LED flash, and the factory data is loaded.

The dot in the seven-segment portion lights, and Factory Reset is completed when the unit switches to Play mode.

NOTE

Never turn off the power while factory data is being loaded.

When the above is completed, the unit quits Test mode.

BLOCK DIAGRAM

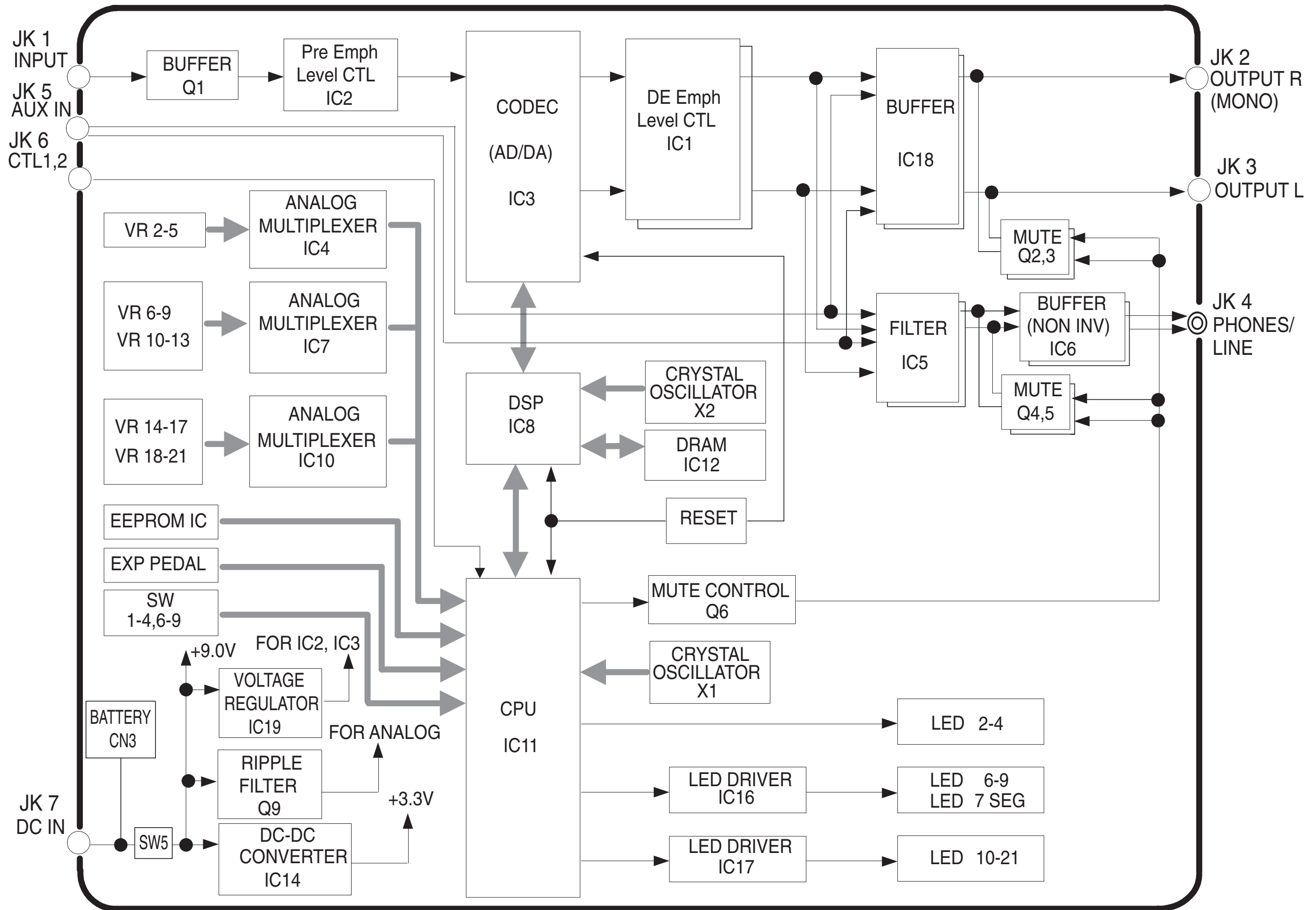

CIRCUIT BOARD

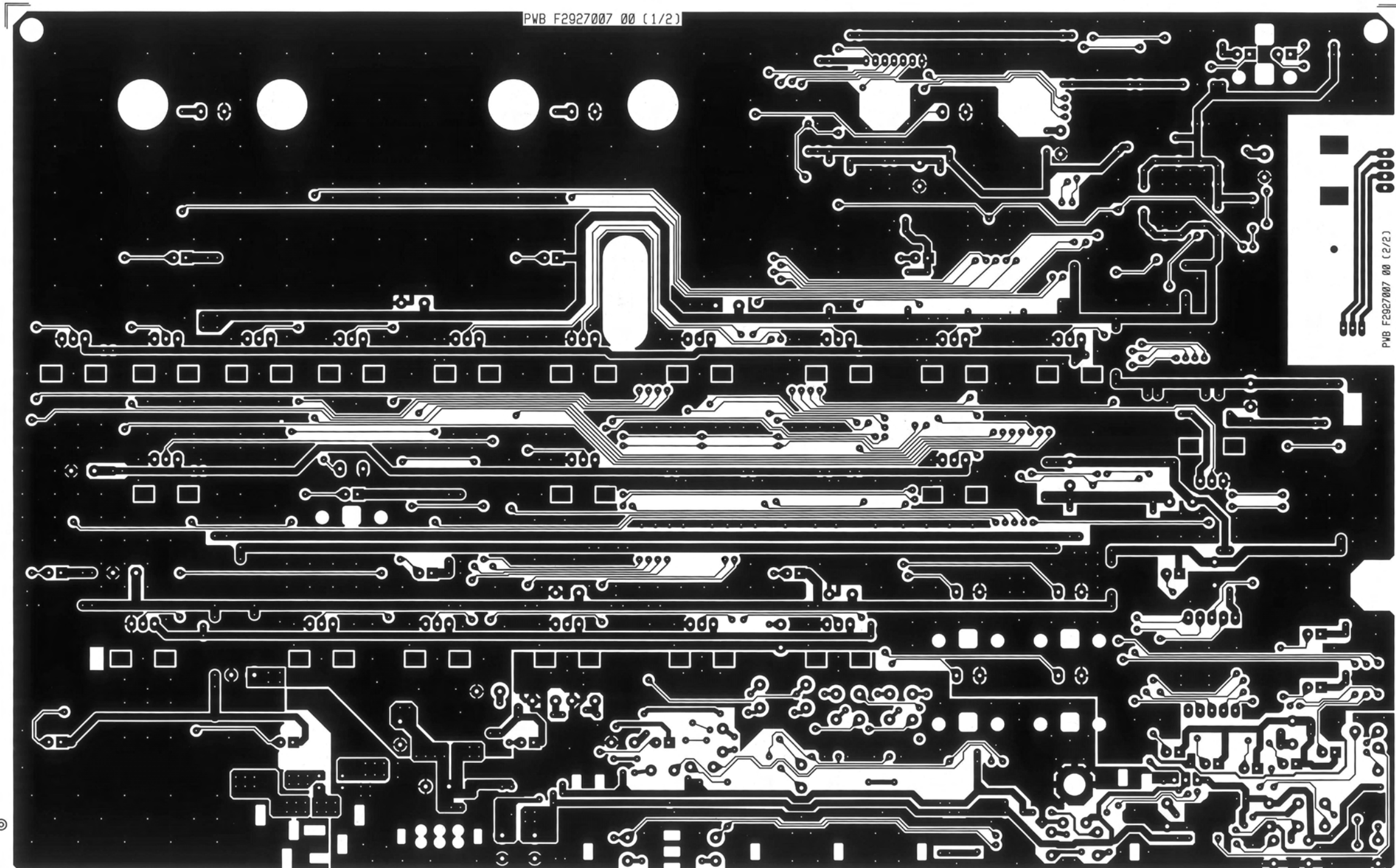

PWB F2927007 00 (1/2)

PWB F2927007 00 (2/2)

ME-50 MAIN SHEET PWB F2927007 00

..

View from foil side

