

| LNK  
 | 050221C2.002  
 | 050221C2.003  
 | 050221C2.004  
 | 050221C2.005  
 | 050221C2.006  
 | 050221C2.007

DOD Electronics Corp.		
8760 South Sandy Parkway Sandy, Utah 84070		
Title GSP21 LEGEND BOARD 1 80-5001		
Size B	Document Number 050221C2.001	Rev C2
Date: Friday, September 01, 2000	Sheet 1 of 7	

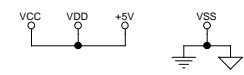

DOD Electronics Corp.		
8760 South Sandy Parkway Sandy, Utah 84070		
Title GSP21 LEGEND BOARD 1 80-5001		
Size B	Document Number 050221C2.002	Rev C2
Date:	Friday, September 01, 2000	Sheet 2 of 7

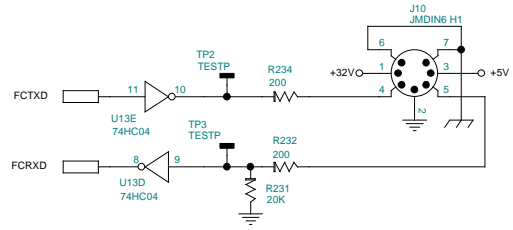
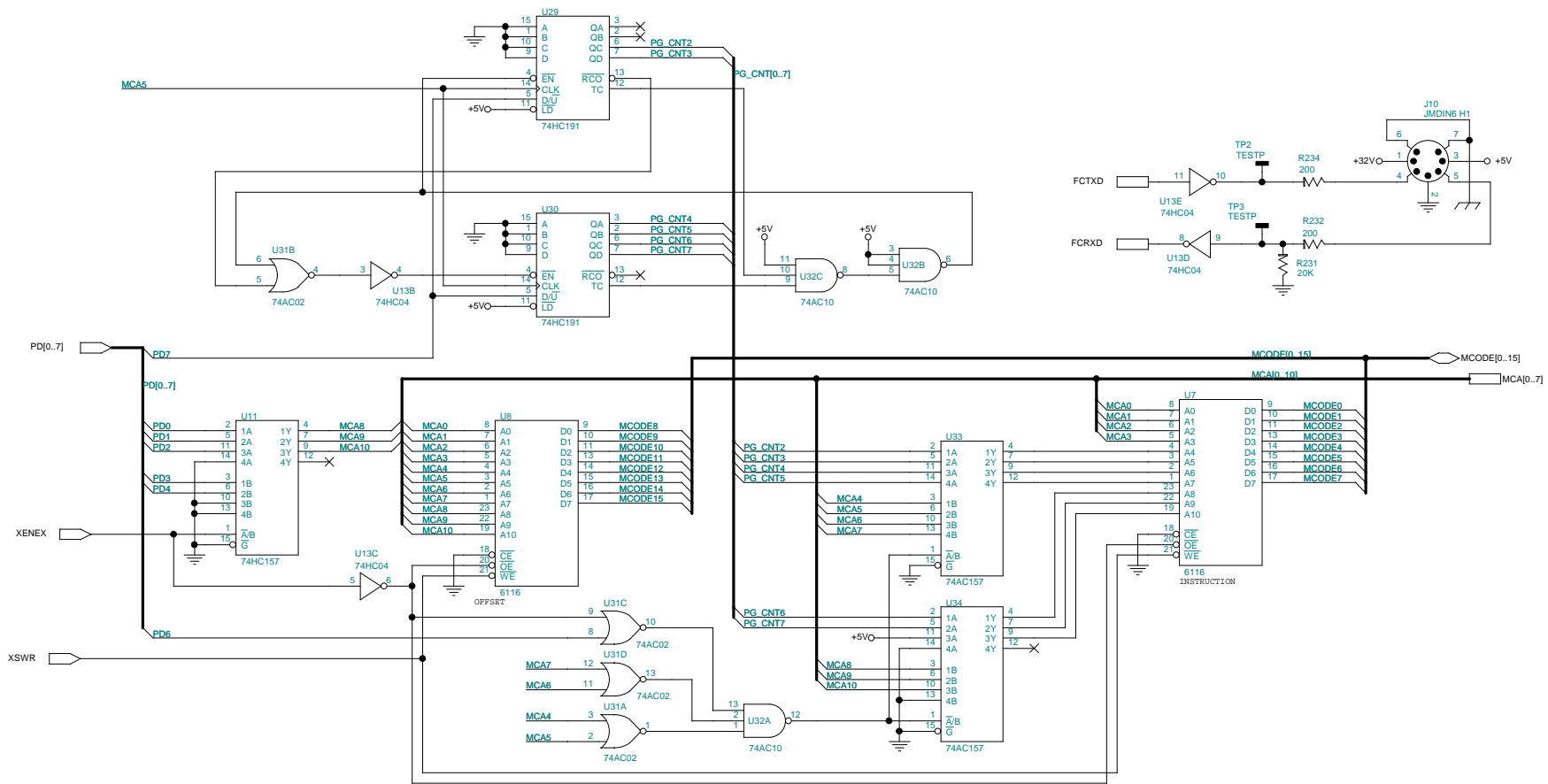
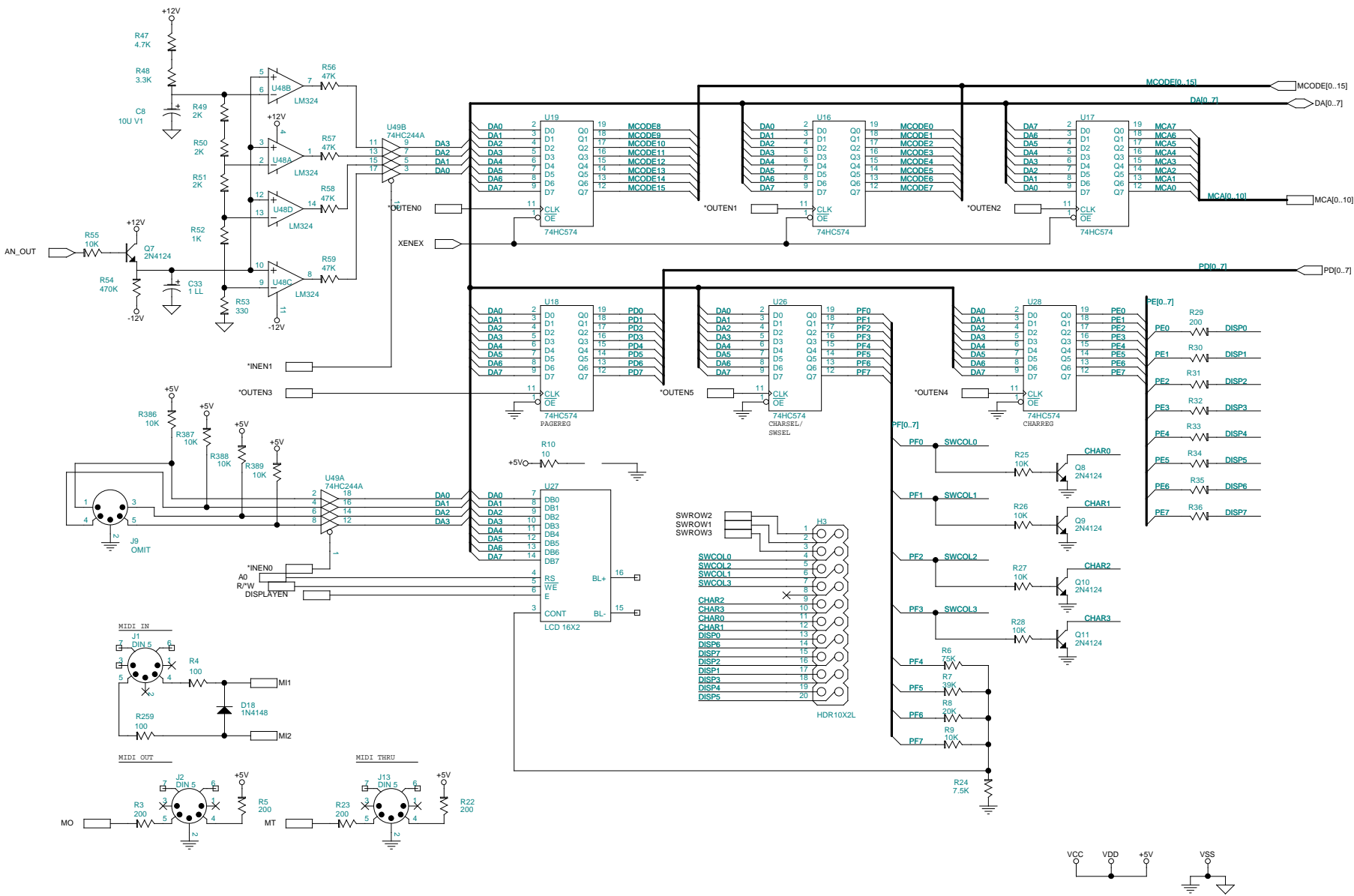

DOD Electronics Corp.  
 8760 South Sandy Parkway  
 Sandy, Utah 84070

Title  
 GSP21 LEGEND BOARD 1 80-5001

Size B Document Number 050221C2.003 Rev C2

Date: Friday, September 01, 2000 Sheet 3 of 7

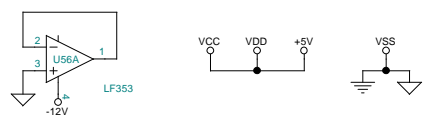
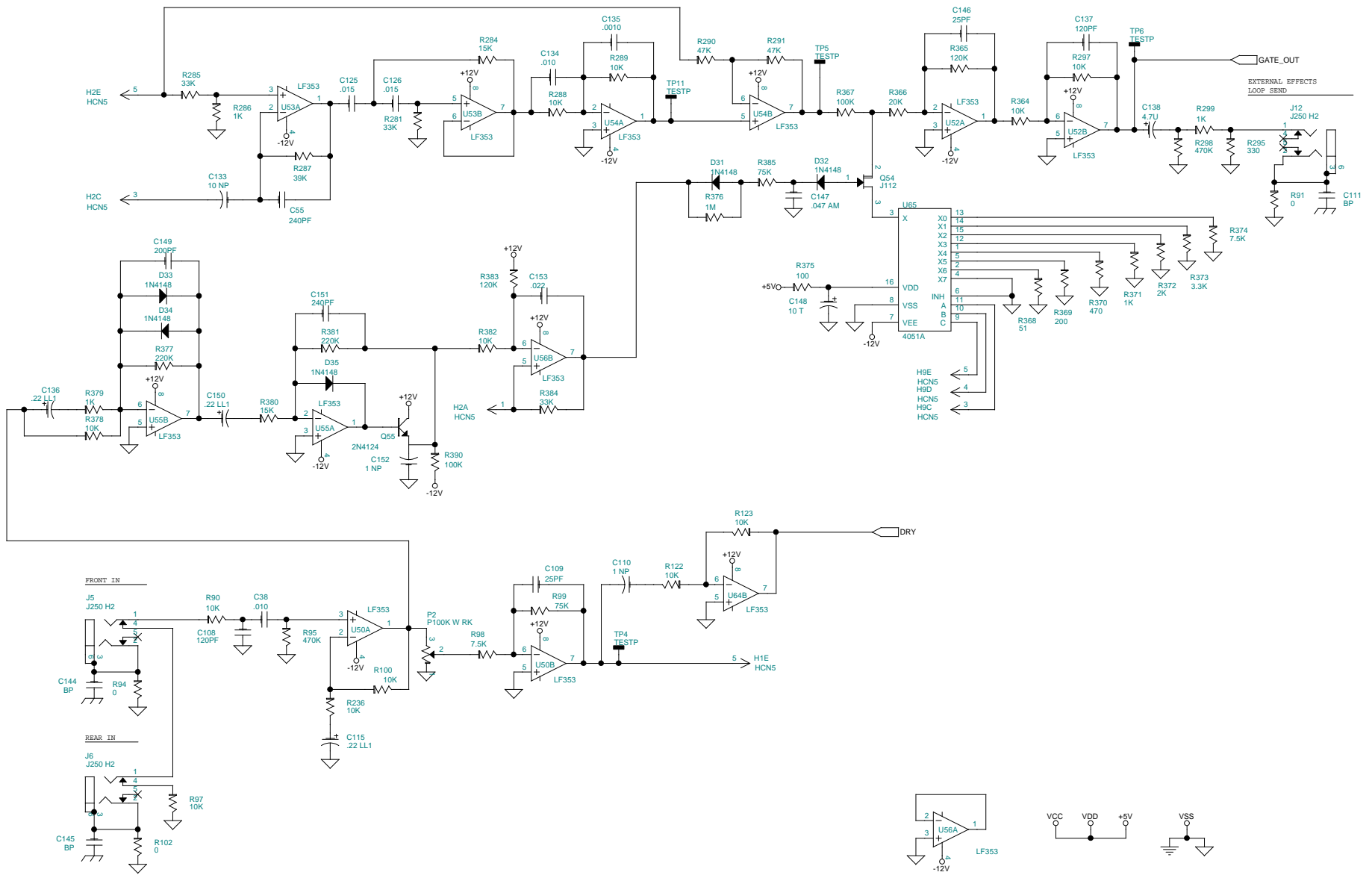

DOD Electronics Corp.		
8760 South Sandy Parkway Sandy, Utah 84070		
Title GSP21 LEGEND BOARD 1 80-5001		
Size B	Document Number 050021C2.004	Rev C2
Date: Friday, September 01, 2000	Sheet 4	of 7

EXTERNAL EFFECTS  
LOOP RETURN RIGHT

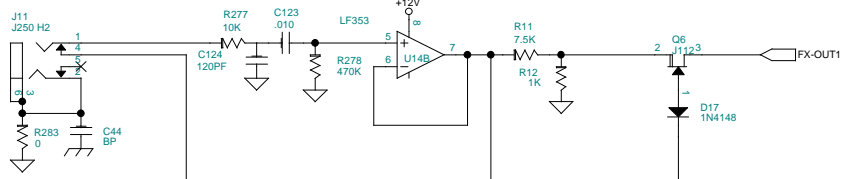

EXTERNAL EFFECTS  
LEFT MONO

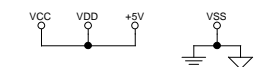
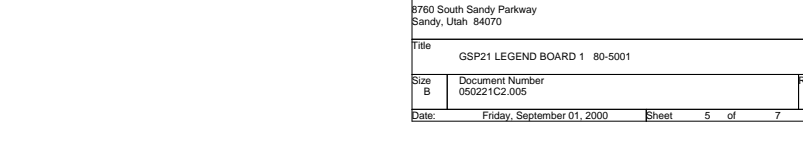
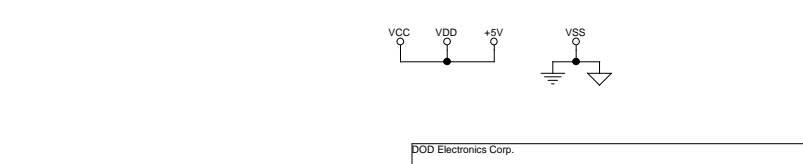
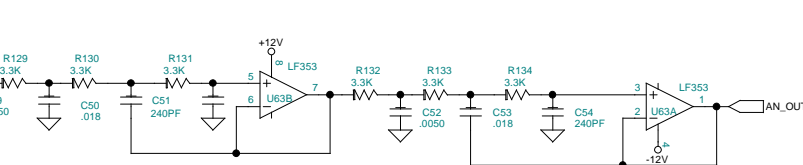
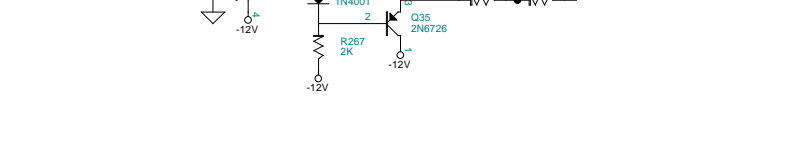
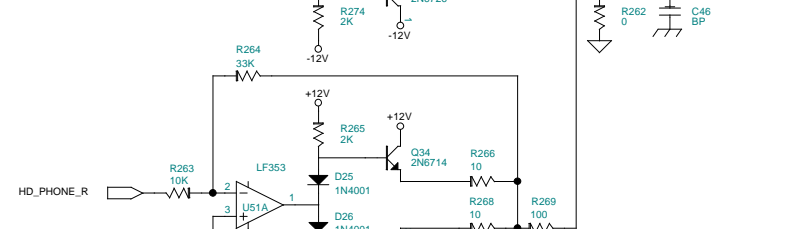
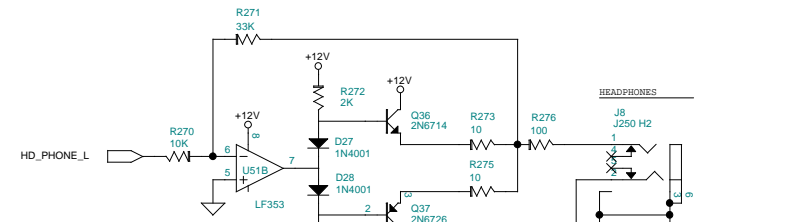
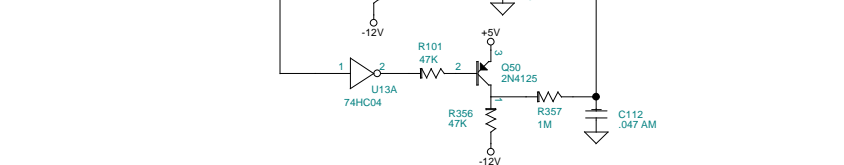
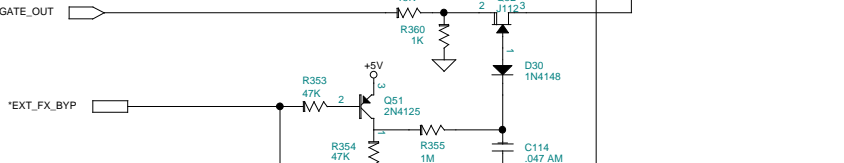
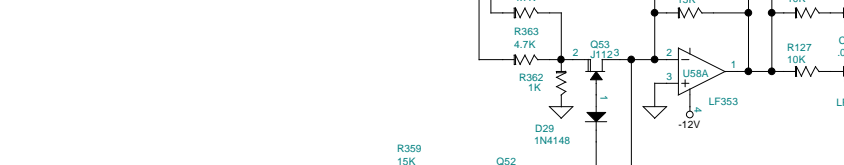
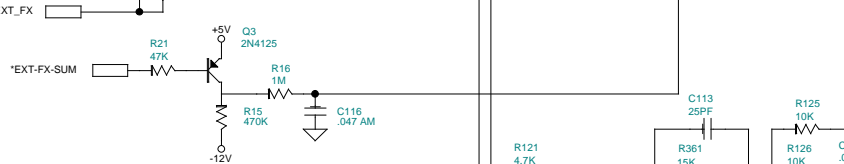
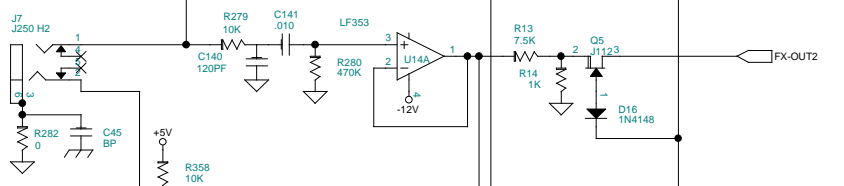

DOD Electronics Corp.		
8760 South Sandy Parkway Sandy, Utah 84070		
Title GSP21 LEGEND BOARD 1 80-5001		
Size B	Document Number 050221C2.005	Rev C2
Date: Friday, September 01, 2000	Sheet 5 of 7	

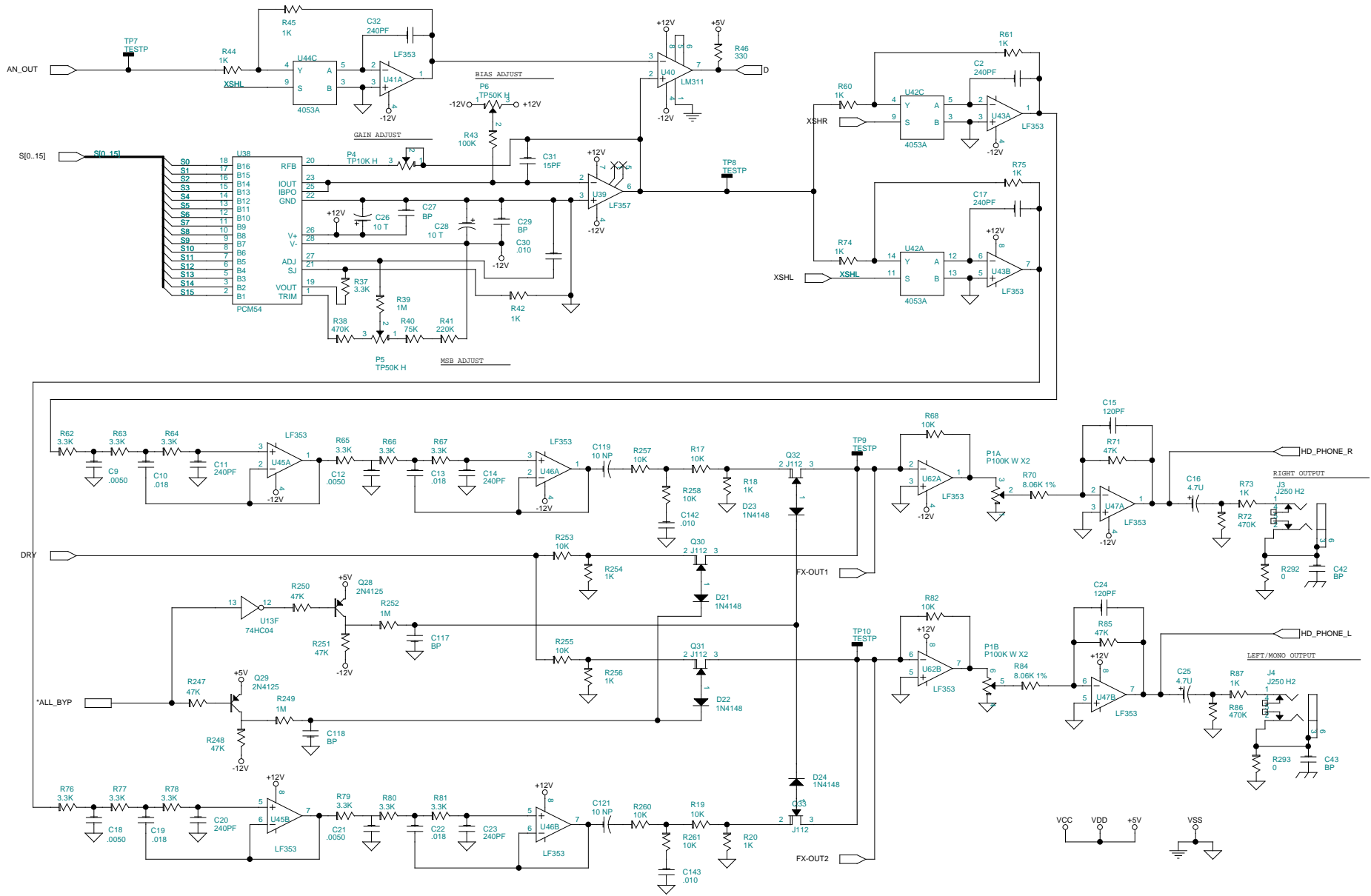

DOD Electronics Corp.	
8760 South Sandy Parkway Sandy, Utah 84070	
Title GSP21 LEGEND BOARD 1 80-5001	
Size B	Document Number 050221C2.006
Date: Friday, September 01, 2000	Sheet 6 of 7
	Rev C2

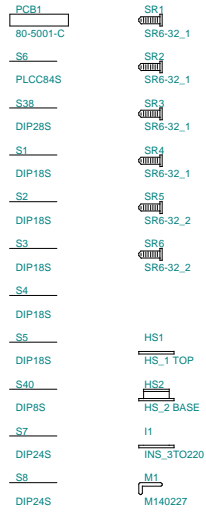
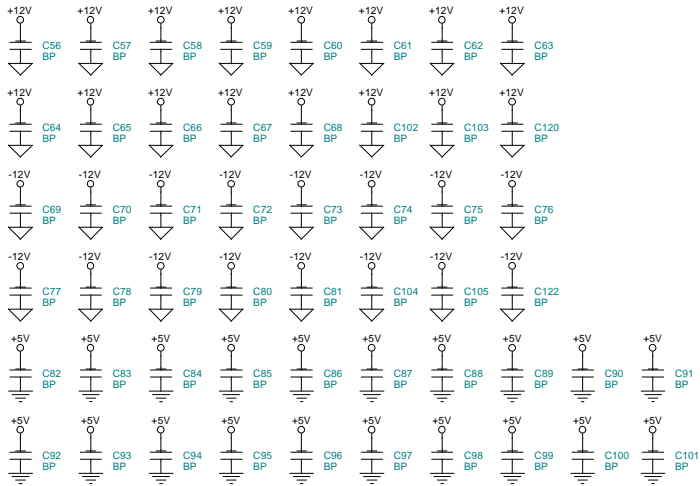
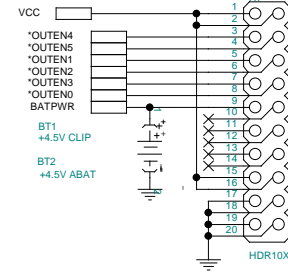
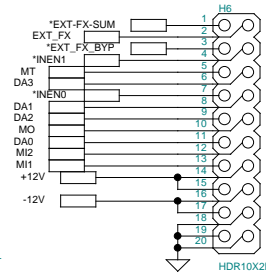
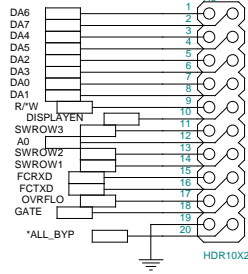
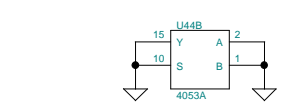
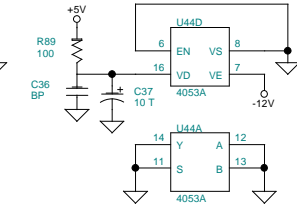
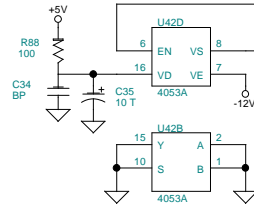
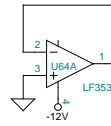
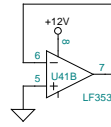
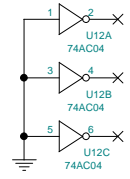
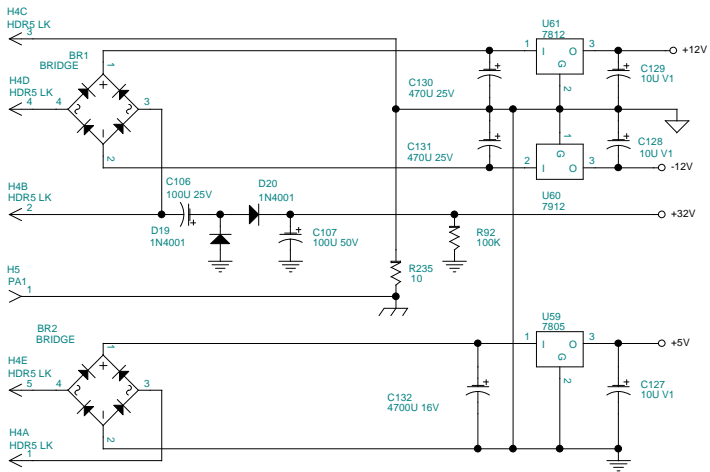

NOT USED  
 C3-7  
 C39-41  
 D1-15  
 Q1, 2, 4  
 F3  
 Q12-27  
 Q38-46  
 R9  
 R101-120, 124  
 R135-230, 233  
 R237-246, 259  
 R302-324  
 R336-344  
 U15  
 U21-25  
 U34-37

LAST REF.  
 BR2  
 BT1  
 C151  
 D32  
 BR  
 J13  
 P6  
 Q54  
 R363  
 U64  
 X1

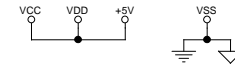

DOD Electronics Corp.		
8760 South Sandy Parkway Sandy, Utah 84070		
Title GSP21 LEGEND BOARD 1 80-5001		
Size B	Document Number 050221C2.007	Rev C2
Date: Friday, September 01, 2000	Sheet 7	of 7

&amp;l0 (sOP (s15H (s8V (sOS &amp;l6D &amp;l66P &amp;l3E &amp;a7L &amp;a120M &amp;l61FDOD Software

Page 1

GSP21 LEGEND BOARD 1 80-5001

Revised: May 23, 1994

050221C2.001

Revision: C2

Bill Of Materials

May 26, 1994

7:46:26

Quan Reference

Part

SYMAN

Description

Quan	Reference	Part	SYMAN	Description
2	BR1, BR2	BRIDGE	70-0129	Bridge Rectifer
1	BT1	+4.5V CLIP	24-1021	Holder For 4.5V Battery
1	BT2	+4.5V ABAT	24-1020	4.5V Battery, Alkaline, Eveready Part #523
4	C1, C109, C113, C146	25PF	62-0001	25 pF Capacitor 5% 50V Ceramic Disc
11	C2, C11, C14, C17, C20, C23, C32, C51, C54, C55, C151	240PF	62-0010	240 pF Capacitor 20% 50V Ceramic Disc
4	C8, C127, C128, C129	10U V1	60-0049-01	10.0 uF Capacitor -20%, +80% 16V Electrolytic-D
6	C9, C12, C18, C21, C49, C52	.0050	56-2016	0.0050 uF Capacitor 10% 100V Polyester Film
6	C10, C13, C19, C22, C50, C53	.018	56-2024	0.018 uF Capacitor 10% 100V Polyester Film
6	C15, C24, C108, C124, C137, C140	120PF	62-0002	120 pF Capacitor 20% 50V Ceramic Disc
3	C16, C25, C138	4.7U	60-0048-01	4.7 uF Capacitor -20%, +80% 16V Electrolytic
5	C26, C28, C35, C37, C148	10 T	62-0163	10.0 uF Capacitor 10% 16V Tantalum
66	C27, C29, C34, C36, C42, C43, C44, C45, C46, C56, C57, C58, C59, C60, C61, C62, C63, C64, C65, C66, C67, C68, C69, C70, C71, C72, C73, C74, C75, C76, C77, C78, C79, C80, C81, C82, C83, C84, C85, C86, C87, C88, C89, C90, C91, C92, C93, C94, C95, C96, C97, C98, C99, C100, C101, C102, C103, C104, C105, C111, C117, C118, C120, C122, C144, C145	BP	62-0067	0.047 uF Capacitor 20% 50V Axial Monolithic
7	C30, C38, C123, C134, C141, C142, C143	.010	56-2022	0.010 uF Capacitor 10% 100V Polyester Film
1	C31	15PF	62-0007	15 pF Capacitor 5% 50V Ceramic Disc
1	C33	1 LL	60-0045-01	1.0 uF Capacitor 20% 50V Elect., LL
1	C47	.0082	56-2019	0.0082 uF Capacitor 10% 100V Polyester Film
1	C48	.0012	56-2009	0.0012 uF Capacitor 10% 100V Polyester Film
1	C106	100U 25V	60-0055	100.0 uF Capacitor -20%, +80% 25V Electrolytic-S
1	C107	100U 50V	60-0068	100.0 uF Capacitor -20%, +80% 50V Electrolytic
2	C110, C152	1 NP	60-0046-01	1.0 uF Capacitor -20%, +80% 16V Elect., N.P.
4	C112, C114, C116, C147	.047 AM	62-0067	0.047 uF Capacitor 20% 50V Axial Monolithic
3	C115, C136, C150	.22 LL1	60-0039-01	0.22 uF Capacitor 20% 50V Electrolytic, LL-D
3	C119, C121, C133	10 NP	60-0051-01	10.0 uF Capacitor -20%, +80% 16V Elect., NP
2	C125, C126	.015	56-2023	0.015 uF Capacitor 10% 100V Polyester Film
2	C130, C131	470U 25V	60-0058	470.0 uF Capacitor -20%, +80% 25V Electrolytic
1	C132	4700U 16V	60-0062	4700.0 uF Capacitor -20%, +80% 16V Electrolytic
1	C135	.0010	56-2008	0.0010 uF Capacitor 10% 100V Polyester Film
1	C149	200PF	62-0009	200 pF Capacitor 20% 50V Ceramic Disc
1	C153	.022	56-2025	0.022 uF Capacitor 10% 100V Polyester Film
14	D16, D17, D18, D21, D22, D23, D24, D29, D30, D31, D32, D33, D34, D35	1N4148	70-0002	1N4148 Silicon Switching Diode, 75 Volts PIV
6	D19, D20, D25, D26, D27, D28	1N4001	70-0001	1N4001 Silicon Rectifier, 1 Amp, 50 Volts PIV
3	H1, H2, H9	HCN5	32-1168	5 Pin Header Connector
4	H3, H6, H7, H8	HDR10X2L	32-1056	20 Pin Hdr, 10x2, 0.1" spacing, 0.025 pins, Long F
1	H4	HDR5 LK	32-1071	5 Pin Header, 0.1" spacing, 0.025" sq pins Lockin
1	H5	PAL	-----	1 Pin Pad, Not a part
1	HS1	HS_1 TOP	70-4204	Heatsink, 3 Regulator, Top

DOD Software

GSP21 LEGEND BOARD 1 80-5001

Revised: May 23, 1994

050221C2.001

Revision: C2

Bill Of Materials

May 26, 1994

7:46:26

Page



Quan	Reference	Part	SYMAN	Description
1	HS2	HS_2 BASE	70-4203	Heatsink, 3 Regulator, U-Shape Base
1	I1	INS_3TO220	70-4209	Insulator, 3 Regulator Heatsink
3	J1,J2,J13	DIN 5	32-0092	5 Pin DIN Jack
8	J3,J4,J5,J6,J7,J8,J11, J12	J250 H2	32-0091	1/4 Phone Jack, PCB Mount
1	J9	OMIT	-----	These parts have been omitted
1	J10	JMDIN6 H1	32-0090	6 Pin Mini DIN Jack
1	M1	M140227		
1	P1	P100K W X2	40-2011	100 K "W" Rot Pot x2, Rack Leads
1	P2	P100K W RK	40-2012	100 K "W" Rot Pot, Rack Style Leads
1	P4	TP10K H	42-0211	10 K Trim Pot, Horizontal Mount, 3/4 turn
2	P5,P6	TP50K H	42-0222	50 K Trim Pot, Horizontal Mount, 3/4 turn
1	PCB1	80-5001-C	80-5001-C	GSP21 LEGEND BOTTOM BOARD REV C BARE
5	Q3,Q28,Q29,Q50,Q51	2N4125	70-1008	2N4125 PNP Gen. Purp. Amplifier/Switching Transis
9	Q5,Q6,Q30,Q31,Q32,Q33, Q52,Q53,Q54	J112	70-1012	J112A JFET National
6	Q7,Q8,Q9,Q10,Q11,Q55	2N4124	70-1009	2N4124 NPN Gen. Purp. Amplifier/Switching Transis
2	Q34,Q36	2N6714	70-1155	NPN Transistor
2	Q35,Q37	2N6726	70-1156	PNP Transistor
2	R1,R370	470	50-0006	470 Ohm Resistor 5% 1/4 Watt Carbon Film
4	R2,R46,R53,R295	330	50-0005	330 Ohm Resistor 5% 1/4 Watt Carbon Film
15	R3,R5,R22,R23,R29,R30, R31,R32,R33,R34,R35,R36, R232,R234,R369	200	50-0004	200 Ohm Resistor 5% 1/4 Watt Carbon Film
7	R4,R88,R89,R259,R269, R276,R375	100	50-0003	100 Ohm Resistor 5% 1/4 Watt Carbon Film
4	R6,R40,R99,R385	75K	50-0033	75 KOhm Resistor 5% 1/4 Watt Carbon Film
2	R7,R287	39K	50-0029	39 KOhm Resistor 5% 1/4 Watt Carbon Film
3	R8,R231,R366	20K	50-0023	20 KOhm Resistor 5% 1/4 Watt Carbon Film
41	R9,R17,R19,R25,R26,R27, R28,R55,R68,R82,R90,R97, R100,R122,R123,R125,R126, R127,R128,R236,R253,R255, R257,R258,R260,R261,R263, R270,R277,R279,R288,R289, R297,R358,R364,R378,R382, R386,R387,R388,R389	10K	50-0020	10 KOhm Resistor 5% 1/4 Watt Carbon Film
6	R10,R235,R266,R268,R273, R275	10	50-0001	10 Ohm Resistor 5% 1/4 Watt Carbon Film
5	R11,R13,R24,R98,R374	7.5K	50-0017	7.5 KOhm Resistor 5% 1/4 Watt Carbon Film
22	R12,R14,R18,R20,R42,R44, R45,R52,R60,R61,R73,R74, R75,R87,R254,R256,R286, R299,R360,R362,R371,R379	1K	50-0012	1 KOhm Resistor 5% 1/4 Watt Carbon Film
9	R15,R38,R54,R72,R86,R95, R278,R280,R298	470K	50-0042	470 KOhm Resistor 5% 1/4 Watt Carbon Film
7	R16,R39,R249,R252,R355, R357,R376	1M	50-0045	1 MOhm Resistor 5% 1/4 Watt Carbon Film
17	R21,R56,R57,R58,R59,R71, R85,R101,R247,R248,R250, R251,R290,R291,R353,R354, R356	47K	50-0030	47 KOhm Resistor 5% 1/4 Watt Carbon Film
DOD Software				Page
GSP21 LEGEND BOARD 1		80-5001	Revised:	May 23, 1994
050221C2.001			Revision:	C2
Bill Of Materials		May 26, 1994	7:46:26	
Quan	Reference	Part	SYMAN	Description
21	R37,R48,R62,R63,R64,R65, R66,R67,R76,R77,R78,R79,	3.3K	50-0014	3.3 KOhm Resistor 5% 1/4 Watt Carbon Film

	R80,R81,R129,R130,R131, R132,R133,R134,R373						
3	R41,R377,R381	220K	50-0040	220	KOhm Resistor	5%	1/4 Watt Carbon Film
4	R43,R92,R367,R390	100K	50-0036	100	KOhm Resistor	5%	1/4 Watt Carbon Film
3	R47,R121,R363	4.7K	50-0015	4.7	KOhm Resistor	5%	1/4 Watt Carbon Film
8	R49,R50,R51,R265,R267, R272,R274,R372	2K	50-0013	2	KOhm Resistor	5%	1/4 Watt Carbon Film
2	R70,R84	8.06K 1%	52-0111	8.06	KOhm Resistor	1%	1/4 Watt Metal Film
8	R91,R94,R102,R262,R282, R283,R292,R293	0	50-0050	0	Ohm Resistor	5%	1/4 Watt Carbon Film
5	R264,R271,R281,R285,R384	33K	50-0028	33	KOhm Resistor	5%	1/4 Watt Carbon Film
4	R284,R359,R361,R380	15K	50-0019	15	KOhm Resistor	5%	1/4 Watt Carbon Film
2	R365,R383	120K	50-0037	120	KOhm Resistor	5%	1/4 Watt Carbon Film
1	R368	51	50-0002	51	Ohm Resistor	5%	1/4 Watt Carbon Film
5	S1,S2,S3,S4,S5	DIP18S	70-3160	18	Pin Dip Socket		
1	S6	PLCC84S	70-3163	84	PLCC Socket		
2	S7,S8	DIP24S	70-3019	24	Pin Dip Socket		
1	S38	DIP28S	70-3161	28	Pin Dip Socket		
1	S40	DIP8S	70-3020	8	Pin Dip Socket		
4	SR1,SR2,SR3,SR4	SR6-32_1	28-0058	Screw, 6-32 x 3/8", Pozi-pan, Black			
1	SR5	SR					
11	TP1,TP2,TP3,TP4,TP5,TP6, TP7,TP8,TP9,TP10,TP11	TESTP	-----	This is not a part.			
5	U1,U2,U3,U4,U5	4464-120					
1	U6	DSP256	72-3138	HISC DSP256 Gate Array			
2	U7,U8	6116	72-3050	2K X 8 CMOS STATIC RAM			
8	U9,U10,U16,U17,U18,U19, U26,U28	74HC574	72-1112	Octal D-Type Pos. Edge Triggered Flip-Flops			
1	U11	74HC157	72-1093	4 X 2 - 1 MUX			
1	U12	74AC04	72-2250	Hex Inverter			
1	U13	74HC04	72-1098	Hex Inverter			
17	U14,U41,U43,U45,U46,U47, U50,U51,U52,U53,U54,U55, U56,U58,U62,U63,U64	LF353	72-4030	LF353 Wide Bandwidth Dual JFET Input Op-Amp			
1	U27	LCD 16X2	70-2167	16 X 2 LCD Array			
2	U29,U30	74HC191	72-1259	UP/DOWN Counter			
1	U31	74AC02	72-2257	4 X 2-IN NOR			
1	U32	74AC10	72-2258	3 X 3-IN NAND			
2	U33,U34	74AC157	72-2251	4 X 2 - 1 MUX			
1	U38	PCM54	72-3079	16 BIT DAC			
1	U39	LF357	72-4041	OP-AMP 50V/US			
1	U40	LM311	72-4027	LM311 Analog Voltage Comparator			
2	U42,U44	4053A	72-0086	Triple 2 Pole Analog Mux			
1	U48	LM324	72-4028	Low Power Quad Operational Amplifier			
1	U49	74HC244A	72-1107	Octal Buffer-Line Driver W/3-State Outputs			
1	U59	7805	70-4014	7805 +5 Volt 1 Amp Voltage Regulator TO-220			
1	U60	7912	70-4017	7912 -12 Volt 1 Amp Voltage Regulator TO-220			
1	U61	7812	70-4013	7812 +12 Volt 1 Amp Voltage Regulator TO-220			
1	U65	4051A	72-0081	8 CH Analog Multiplex			
1	X1	36.0 MHZ	76-0328	36.00 MHZ Crystal			