

SP-404

SERVICE NOTES

Issued by RJA

TABLE OF CONTENTS

CAUTIONARY NOTES	2	SYSTEM UPDATE INSTRUCTIONS	15
SPECIFICATIONS.....	3	TEST MODE.....	16
LOCATION OF CONTROLS	4	BLOCK DIAGRAM.....	18
LOCATION OF CONTROLS PARTS LIST	5	CIRCUIT BOARD (MAIN BOARD).....	20
EXPLODED VIEW 1	6	CIRCUIT DIAGRAM (MAIN BOARD DIGITAL)	22
EXPLODED VIEW 1 PARTS LIST	7	CIRCUIT DIAGRAM (MAIN BOARD ANALOG)	24
EXPLODED VIEW 2	8	CIRCUIT BOARD (PANEL BOARD, JACK BOARD).....	26
EXPLODED VIEW 2 PARTS LIST	9	CIRCUIT DIAGRAM (PANEL BOARD, JACK BOARD).....	28
PARTS LIST.....	10	ERROR MESSAGES	30
CHECKING THE VERSION NUMBER.....	14		
USERS DATA SAVE AND LOAD.....	14		
Instructions for System Initialize	14		

Revise Information

2006/10/25

The circuit diagram of Main Board (analog section) (p. 24) was added.

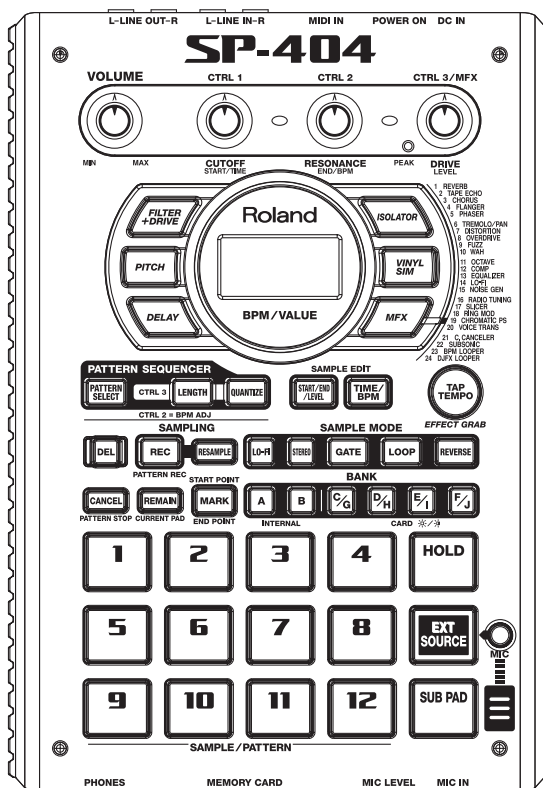

Copyright © 2005 ROLAND CORPORATION

All rights reserved. No part of this publication may be reproduced in any form without the written permission of ROLAND CORPORATION.

CAUTIONARY NOTES

TAKE BACKUP OF USER DATA

User data status after each of the following processes is described below.

Whenever carrying out procedures that involve deleting or erasing user data, always be sure to back up the user data to some form of external media (refer to USERS DATA SAVE AND LOAD).

Process	USER DATA
Checking Version number	Preserved
Factory Reset	Deleted
System Update	Preserved
Test Mode	Deleted

PARTS LIST

Due to one or more of the following reasons, parts with parts code ***** cannot be supplied as service parts.

- Part supplied only as a component in a complete assembly.
- Copyright does not permit the part to be supplied.
- Part is sold commercially.

CIRCUIT BOARD

“NIU” meant that “NOT IN USE” there don't set any contents in the Circuit Diagram.

There has silk-screen only in the Circuit Board.

SPECIFICATIONS

SP-404: Sampler

Maximum Polyphony

12 voices

Internal Memory

Samples: 24 (12 samples x 2 banks)

* Including Pre-loaded Samples

Patterns: 24 (12 patterns x 2 banks)

* Including Pre-loaded Patterns

Memory Card (CompactFlash)

Samples: 96 (12 samples x 8 banks)

Patterns: 96 (12 patterns x 8 banks)

Maximum Sampling Time (mono, approx.)

Internal Memory (Including Pre-loaded Samples)

STANDARD	LO-FI
5min.	11min.

Memory Card (CompactFlash)

CARD CAPACITY	STANDARD	LO-FI
32MB	12min.	24min.
64MB	24min.	48min.
128MB	48min.	96min.
256MB	96min.	193min.
512MB	193min.	386min.
1GB	386min.	772min.

Sampling Frequency

44.1 kHz

Data Format

SP-404 original format

(WAV/AIFF import/export possible)

Sampling Mode

STANDARD, LO-FI

Pattern Sequencer

Maximum recordable notes:

Internal Memory: Approx. 8,000 notes

* Including Pre-loaded Patterns

Memory Card (CompactFlash): Approx. 8,000 notes

Resolution: 96 ticks per quarter note

Pattern Length: 1-99 measures

Recording method: Realtime Loop Recording

(with quantize function)

Effects

29 types

Signal Processing

AD Conversion: 24 bits

DA Conversion: 24 bits

Display

7 segments, 3 characters (LED)

Onboard Mic

Mono x 1

Connectors

LINE INPUT Jacks (L, R) (RCA phono type)

LINE OUTPUT Jacks (L, R) (RCA phono type)

Headphones (PHONES) Jack (Stereo 1/4 inch phone type)

MIC Jack (1/4 inch phone type)

MIDI IN Connector

AC Adaptor Jack

Memory Card Slot (CompactFlash)

Power Supply

DC 9 V (Dry battery LR6 (AA) type x 6 or AC Adaptor)

Expected battery life under continuous use:

Alkaline: 6 hours

* These figures will vary depending on the actual conditions of use.

Current Draw

300 mA

Dimensions

177.6 (W) x 256.7 (D) x 72.1 (H) mm

7 (W) x 10-1/8 (D) x 2-7/8 (H) inches

Weight

1.3 kg

2 lbs 14 oz

(excluding batteries)

Accessories

AC Adaptor (without AC Cord)(#03017356)

AC Cord (117V)(#02562456)

AC Cord (230V EU)(#01903356)

EURO CONVERTER PLUG (#00905234)

AC Cord (230V E)(Cord "#01903356" + Plug "00905234")

AC Cord (240V A)(#03785590)

Owner's Manual (ENGLISH)(#73017212)

Owner's Manual (JAPANESE)(OPTION)(#73016067)

Recommended Memory Cards

As of the date of writing, Roland has confirmed that the following memory cards work correctly with the SP-404.

(As of September 1, 2005)

Manufacturer	Model
BUFFALO	RCF-G(256MB,1GB), RCF-X(32MB,64MB,128MB,512MB)
HAGIWARA SYS-COM (Zpro)	HPC-CF128ZP(128MB), HPC-CF512ZP(512MB), HPC-CF1GZP(1GB)
I-O DATA	CFS-32M(32MB)
SanDisk (ultra2)	SDCFH-256-903(256MB), SDCFH-512-903(512MB), SDCFH-1024-903(1GB)

* Supported capacities : 32MB,64MB,128MB,256MB,512MB,1GB

* In the interest of product improvement, the specifications and/or appearance of this unit are subject to change without prior notice.

LOCATION OF CONTROLS

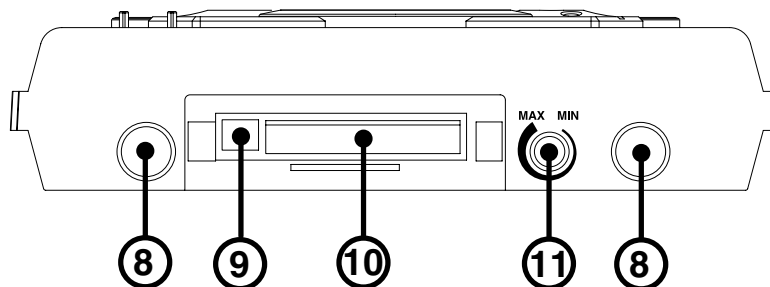
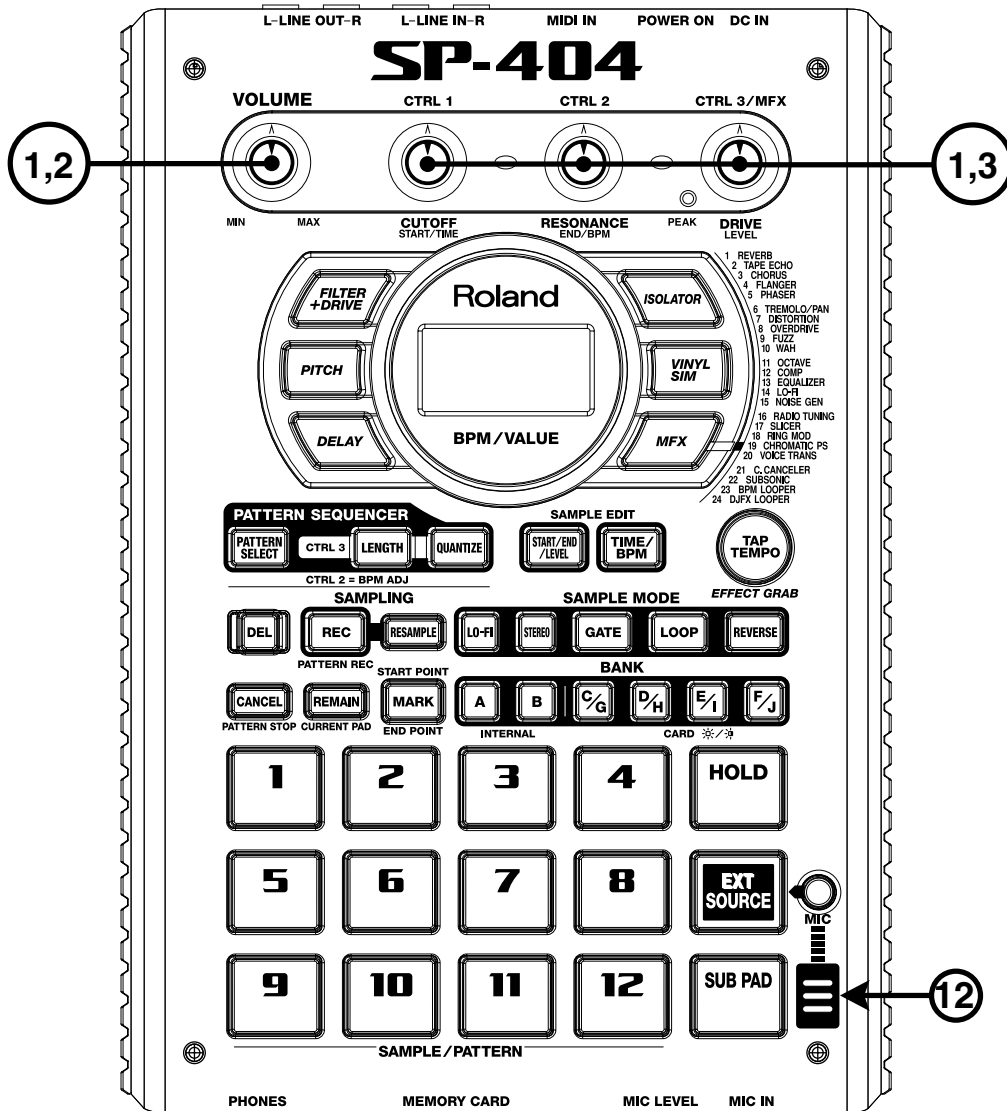
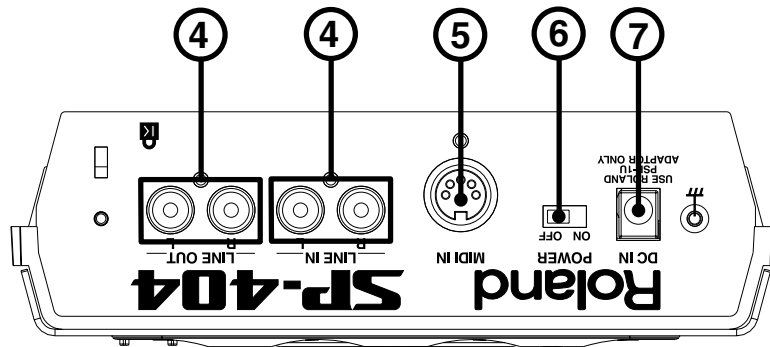

LOCATION OF CONTROLS PARTS LIST

NO	PART CODE	PART NAME	DESCRIPTION	Q'TY
1	03565234	J R-KNOB	SF-ELA BLK/SLV	4
2	04011745	ROTARY POTENTIOMETER	RK09K12C0A8H	1
3	03679256	ROTARY POTENTIOMETER	RK09D1130C5B	3
4	01899801	JACK	YKC21-3834	2
5	01566445	DIN CONNECTOR	YKF51-5067	1
6	02671312	SLIDE SWITCH	SLG-22-465	1
7	13449711	AC ADAPTOR JACK	HEC0470-01-630	1
8	13449275	6.5MM JACK	YKB21-5074	2
9	03121689	COMPACTFLASH EJECTOR	ICM-MAE-R21	1
10	03121678	CARD CONNECTOR	ICM-MA2H-SS52-R21A	1
11	13279884	RK09K1110 10KB	POTENTIOMETER	1
12	03679190	MIC	WM-64PNT	1

EXPLODED VIEW 1

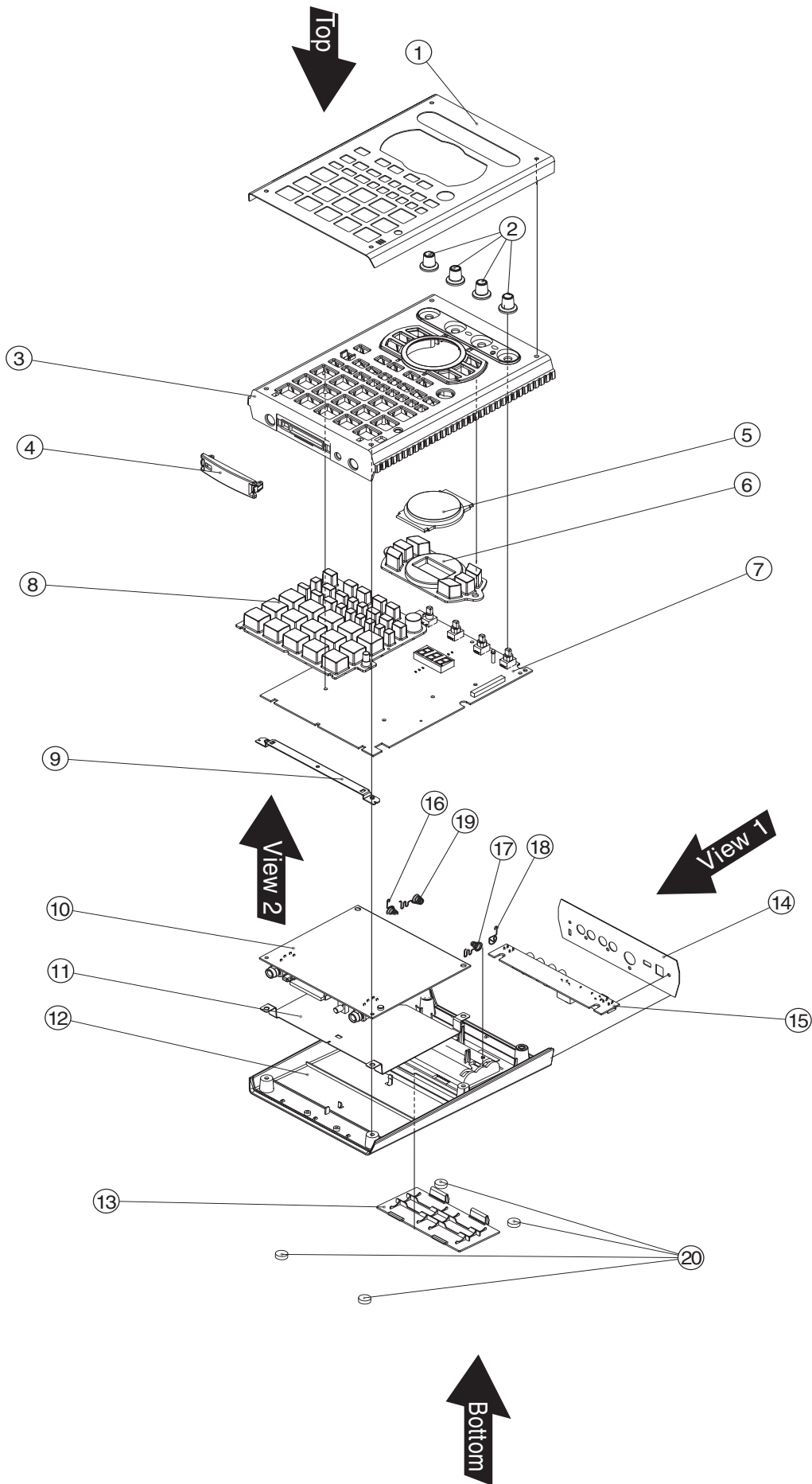

EXPLODED VIEW 1 PARTS LIST

NO	PART CODE	PART NAME	DESCRIPTION	Q'TY
1	03909034	TOP PANEL		1
2	03565234	J R-KNOB	SF-ELA BLK/SLV	4
3	03909023	TOP CASE		1
4	03908956	CF COVER		1
5	03908967	DISPLAY COVER		1
6	03908990	RUBBER SW EFFECT		1
7	73016112	PANEL BOARD ASSY		1
	NOTE: "PANEL BOARD ASSY" includes the following parts.			
	04010601	LED SPACER	LH-3-12	
8	03909001	RUBBER SW PAD		1
9	03908978	PWB HOLDER MAIN		1
10	73016089	MAIN BOARD ASSY		1
11	03909012	SHIELD PLATE		1
12	03908945	BOTTOM CASE		1
13	03908901	BATTERY COVER		1
	NOTE: When you place an order for #03908901, please place an order for the following two #40672389. The following parts prevent the shake of a battery. Please stick #40672389 on #03908901.			
	40672389	BATTERY CUSHION		2
14	03908989	REAR PANEL		1
15	73016134	JACK BOARD ASSY		1
16	03908923	BATTERY TERMINAL -		1
17	03908934	BATTERY TERMINAL +-		1
18	03908912	BATTERY TERMINAL +		1
19	04120734	BATTERY TERMINAL PM		1
20	00340690	FOOT ZULEN (CUSHION)	XCK040 12MM	4

EXPLODED VIEW 2

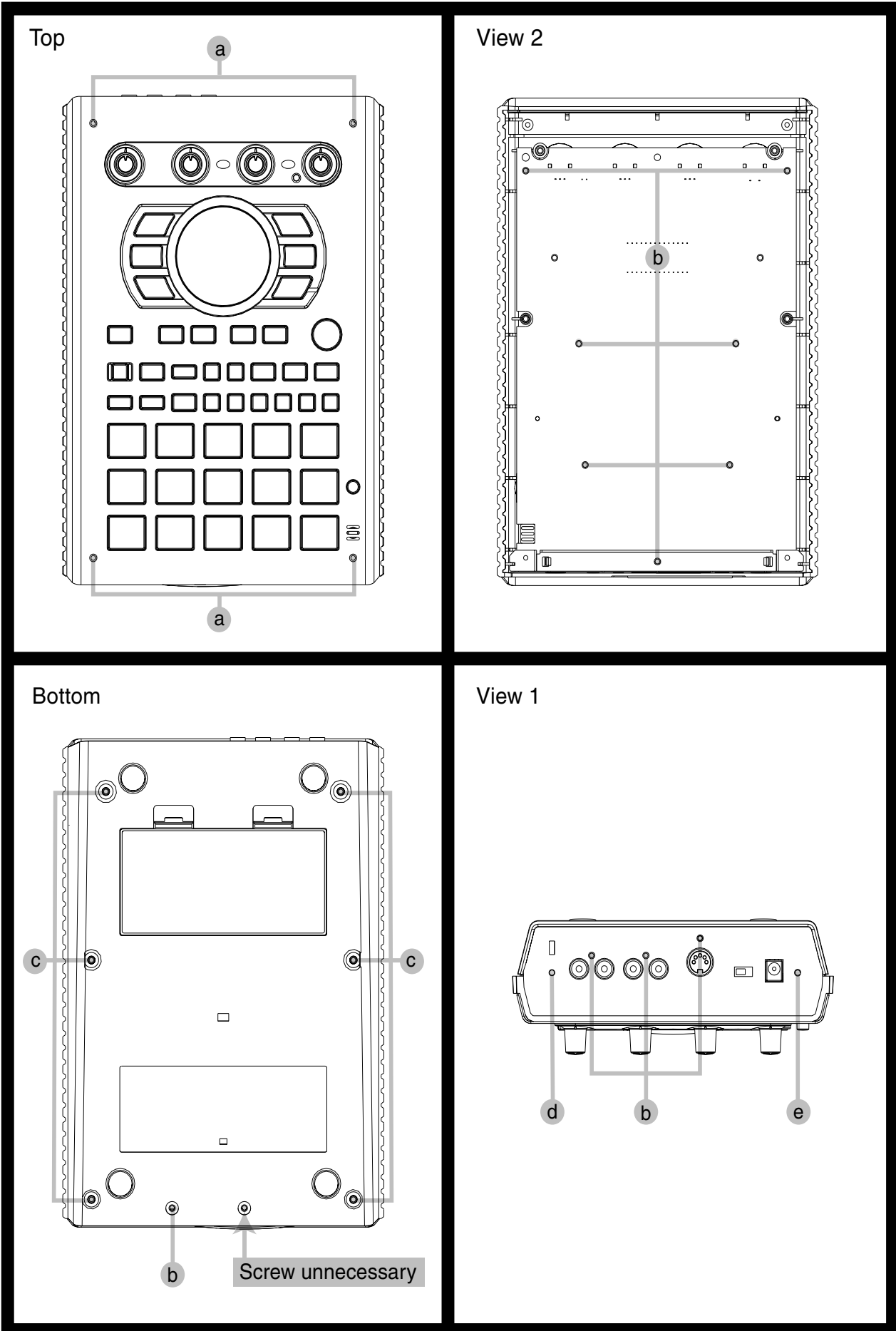

EXPLODED VIEW 2 PARTS LIST

No	PART CODE	PART NAME	DESCRIPTION	Q'TY
a	02126156	SCREW M3X10	HEX SOCKET HEAD CAP TAPTITE P	4
b	40011312	SCREW 3X8	BINDING TAPTITE P BZC	11
c	40011112	SCREW 3X10	BINDING TAPTITE B BZC	6
d	40011490	SCREW M3X6	PAN MACHINE W/SW BZC	1
e	40230590	SCREW M3X10	BINDING MACHINE NI	1

PARTS LIST

SAFETY PRECAUTIONS:

The parts marked Δ have safety-related characteristics. Use only listed parts for replacement.

Due to one or more of the following reasons, parts with parts code ***** cannot be supplied as service parts.

- Part supplied only as a component in a complete assembly
- Copyright does not permit the part to be supplied
- Part is sold commercially

NOTE: The parts marked # are new. (initial parts) The description "Q'TY" means a necessary number of the parts per one product.

CASING					
#	03908945	BOTTOM CASE			1
#	03909023	TOP CASE			1
#	03908901	BATTERY COVER			1
NOTE: When you place an order for #03908901, please place an order for the following two #40672389.					
The following parts prevent the shake of a battery. Please stick #40672389 on #03908901.					
#	03908967	DISPLAY COVER			1
#	03908956	CF COVER			1
#	03908989	REAR PANEL			1
#	03909034	TOP PANEL			1
#	03909012	SHIELD PLATE			1
CHASSIS					
#	03908978	PWB HOLDER MAIN			1
KNOB, BUTTON					
	03565234	J R-KNOB	SF-ELA BLK/SLV		4
#	03908990	RUBBER SW EFFECT			1
#	03909001	RUBBER SW PAD			1
SWITCH					
	02671312	SLIDE SWITCH	SLG-22-465	SW1 on Panel Sheet	1
JACK, EXT TERMINAL					
	03121678	CARD CONNECTOR	ICM-MA2H-SS52-R21A	CN1 on Main board	1
	03121689	COMPACTFLASH EJECTOR	ICM-MAE-R21		1
	13449275	6.5MM JACK	YKB21-5074	JK1,JK2 on Main board	2
	01566445	DIN CONNECTOR	YKF51-5067	JK2 on Panel Sheet	1
	01899801	JACK	YKC21-3834	JK1,JK3 on Panel Sheet	2
	13449711	AC ADAPTOR JACK	HEC0470-01-630	JK4 on Panel Sheet	1
DISPLAY UNIT					
	01342534	SL-9351S	LED 7 SEGMENT	LED1 on Panel Sheet	1
NOTE: Replacement SL-9351S should be made on a unit base.					
PCB ASSY					
#	73016089	MAIN BOARD ASSY			1
#	73016112	PANEL BOARD ASSY			1
NOTE: 'PANEL BOARD ASSY' includes the following parts.					
#	04010601	LED SPACER	LH-3-12		1
#	73016134	JACK BOARD ASSY			1
IC					
#	03909523	UPD703107AGJ-218-UEN-A	IC (CPU)	IC2 on Main board	1
#	03909712	LC4032V-75TN48C SP-404	IC (CUSTOM)	IC11 on Main board	1
	02565501	TC220CCA0AF-B01(MR3)	IC (DSP)	IC10 on Main board	1
	02121556	LC24085B-SD1	IC (I/F)	IC4 on Main board	1
	02457634	MBM29LV160BE70TN-K	IC (FLASH MEMORY)	IC8 on Main board	1
	03349478	TC58DVM72A1TG00BBH	IC (FLASH MEMORY)	IC6 on Main board	1
	03348812	M12L16161A-7T	IC (SDRAM)	IC3 on Main board	1
	02451434	AK4552VT	IC (AD/DA)	IC20 on Main board	1
	02458090	TC4066BFT(EL)	IC (CMOS)	IC17 on Main board	1
	02675689	HD74LV245ATELL	IC (CMOS)	IC1,IC5,IC7,IC9 on Main board	4
	00346445	NJM2100M(TE3)	IC (BIPOLAR OP AMP)	IC18 on Main board	1
	15189261	M5218AFP-600E	IC (BIPOLAR OP AMP)	IC22 on Main board	1

IC				
15289105	UPC4570G2-E2	IC (BIPOLAR OP AMP)	IC21,IC24,IC16,IC19 on Main board	4
01906156	S-8520E33MC-BJS-T2	IC (DC-DC REGULATOR)	IC15 on Main board	1
03015923	S-80130ANMC	IC (RESET)	IC14 on Main board	1
15289124	PC-400T	IC (PHOTO COUPLER)	IC23 on Main board	1
01675034	TC74VHC138FT(EL)	IC CMOS	IC1 on Panel Sheet	1
02453056	BU2090FS-E2	IC (LED DRIVER)	IC2,IC3 on Panel Sheet	2
TRANSISTOR				
15309101	2SA1037AKT146R	TRANSISTOR	Q12,Q4 on Main board	2
15319102	2SC2882-Y(TE12L.C)	TRANSISTOR	Q3 on Main board	1
00239812	DTC114EUT106	TRANSISTOR	Q10,Q5 on Main board	2
15329505	DTC314TK T146	DIGITAL TRANSISTOR	Q6,Q7,Q8,Q11 on Main board	4
15329511	DTC114TKT146	DIGITAL TRANSISTOR	Q13 on Main board, Q16,Q15,Q8,Q7,Q6,Q11,Q12,Q13,Q9, Q14,Q10 on Panel Sheet	12
03892989	CPH6316-TL-E	TRANSISTOR	Q2,Q1 on Main board	2
01783612	RN2426(TE85L)	TRANSISTOR	Q2,Q3,Q4,Q5,Q1 on Panel Sheet	5
DIODE				
02780401	MA720-(TX)	SCHOTTKY DIODE	D1 on Main board	1
03452167	RB160L-40 TE25	SCHOTTKY DIODE	D2 on Main board	1
01897189	MA147-(TX)	ARRAY DIODE	DA3,DA2,DA4,DA5,DA6,DA1 on Main board	6
15339130	MA142WK-(TX)	ARRAY DIODE	DA17,DA18,DA19,DA21,DA22,DA20, DA10,DA15,DA14,DA13,DA11,DA16,DA9, DA8,DA7,DA6,DA5,DA4,DA3,DA2,DA1, DA12 on Panel Sheet	22
01904112	SLR-342VCT32 N.P.Q RANK	LED(RED)	LED19 on Panel Sheet	1
02671245	SML-310LTT86	LED(RED)	LED18 on Panel Sheet	1
03459534	TLSU1002A(TO2)	LED(RED)	LED27,LED29,LED30,LED31,LED32, LED33,LED28,LED34,LED35,LED36, LED37,LED26,LED39,LED40,LED41, LED43,LED38,LED11,LED2,LED3,LED4, LED5,LED6,LED7,LED8,LED17,LED10, LED25,LED12,LED13,LED14,LED15, LED44,LED16,LED22,LED23,LED24,LED9, LED42,LED45 on Panel Sheet	40
03560901	SML-311BBT86	LED (BLUE)	LED20,LED21 on Panel Sheet	2
RESISTOR				
00566890	RPC05T 150 J	MTL.FILM RESISTOR	R79 on Main board	1
00567023	RPC05T 101 J	MTL.FILM RESISTOR	R160,R56,R118,R70,R55,R50,R14,R10,R137, R12,R125 on Main board,R19 on Panel Sheet	12
00567034	RPC05T 121 J	MTL.FILM RESISTOR	R156 on Main board	1
00567045	RPC05T 151 J	MTL.FILM RESISTOR	R129 on Main board	1
00567089	RPC05T 331 J	MTL.FILM RESISTOR	R60,R123,R114 on Main board, R22,R21,R17,R20,R40,R45,R44,R43,R18,R41, R23,R39,R38,R37,R36,R35,R25,R42,R24,R34, R26,R27,R29,R30,R28,R33,R31, R32 on Panel Sheet	31
00567134	RPC05T 681 J	MTL.FILM RESISTOR	R113,R122 on Main board	2
00567178	RPC05T 152 J	MTL.FILM RESISTOR	R1 on Main board	1
00567067	RPC05T 221 J	MTL.FILM RESISTOR	R71,R75,R159 on Main board	3
00567156	RPC05T 102 J	MTL.FILM RESISTOR	R158,R82,R85,R128 on Main board	4
00567301	RPC05T 153 J	MTL.FILM RESISTOR	R120,R108 on Main board	2
00567312	RPC05T 183 J	MTL.FILM RESISTOR	R67 on Main board	1
00567345	RPC05T 333 J	MTL.FILM RESISTOR	R100,R116 on Main board	2
00566967	RPC05T 470 J	MTL.FILM RESISTOR	R38,R33,R35,R39,R37,R36,R72,R32,R41,R34, R40,R42,R43,R44,R45,R49,R52,R58,R63,R66, R31,R4,R65,R11,R3,R5,R7,R6,R9,R30,R13, R15,R16,R17,R26,R8,R18,R29,R25,R24,R23, R22,R21,R20,R19,R27 on Main board	46
00567501	RPC05T 474 J	MTL.FILM RESISTOR	R115,R126 on Main board	2
00567556	RPC05T 105 J	MTL.FILM RESISTOR	R78,R131,R161 on Main board	3
03236123	RPC05T 2R2 J	MTL.FILM RESISTOR	R99,R140,R144,R98 on Main board	4
00566912	RPC05T 220 J	MTL.FILM RESISTOR	R185,R195,R193,R191,R189,R187,R197, R183,R181,R177,R173,R171,R198,R167, R179,R169,R236,R224,R225,R227,R230, R222,R234,R228,R200,R175,R243,R237, R239,R240,R242,R233,R209,R201,R203, R204,R206,R231,R207,R221,R210,R212, R215,R219,R218,R216,R213 on Main board, R9,R16,R15,R14,R13,R12,R11, R10 on Panel Sheet	55
00567412	RPC05T 104 J	MTL.FILM RESISTOR	R124,R155,R102,R94,R74,R73,R59,R106,R68, R143,R154,R69,R132,R145 on Main board	14
01011856	RPC05T 0R0 J	MTL.FILM RESISTOR	R54,R127,R57,R162,R90 on Main board, R46,R47 on Panel Sheet	7
01344723	MCR25 JZH J 220 OHM 1/4W	MTL.FILM RESISTOR	R152,R139,R138,R153 on Main board	4

RESISTOR					
	00567289	RPC05T 103 J	MTL.FILM RESISTOR	R192,R194,R196,R199,R223,R211,R214,R220,R202,R190,R226,R180,R205,R208,R217,R61,R136,R184,R121,R109,R188,R64,R141,R53,R51,R48,R47,R46,R28,R2,R81,R174,R186,R229,R182,R241,R134,R176,R147,R172,R170,R168,R163,R151,R150,R148,R178,R238,R235,R244,R245,R232 on Main board	52
	00567378	RPC05T 473 J	MTL.FILM RESISTOR	R104,R103,R101,R97,R96,R95,R110,R91,R135,R62,R92,R111,R117,R146,R149,R157,R112 on Main board	17
	00567278	RPC05T 822 J	MTL.FILM RESISTOR	R119,R107 on Main board	2
	00567267	RPC05T 682 J	MTL.FILM RESISTOR	R130 on Main board	1
	00567245	RPC05T 472 J	MTL.FILM RESISTOR	R166,R164 on Main board	2
	00567190	RPC05T 222 J	MTL.FILM RESISTOR	R133,R80,R83 on Main board	3
	03015278	EXB28V220JX	RESISTOR-ARRAY	RA42,RA48,RA35,RA38,RA41,RA44,RA45,RA47,RA58,RA56,RA50,RA52,RA54,RA39 on Main board	14
	03015289	EXB28V103JX	RESISTOR-ARRAY	RA66,RA14,RA40,RA26,RA34,RA36,RA37,RA62,RA67,RA65,RA64,RA63,RA43,RA61,RA60,RA59,RA57,RA55,RA53,RA51,RA49,RA46 on Main board	22
#	03348012	EXB28V101JX	RESISTOR-ARRAY	RA33,RA68,RA69 on Main board	3
	03785712	EXB28V470JX	RESISTOR-ARRAY	RA23,RA25 on Main board	2
	00566934	RPC05T 330 J	MTL.FILM RESISTOR	R4,R8,R7,R5,R3,R2,R1,R6 on Panel Sheet	8
POTENTIOMETER					
	13279884	RK09K1110 10KB	POTENTIOMETER	VR1 on Main board	1
#	03679256	ROTARY POT. RK09D1130C5B	ROTARY POTENTIOMETER	VR3,VR1,VR2 on Panel Sheet	3
#	04011745	ROTARY POT. RK09K12C0A8H	ROTARY POTENTIOMETER	VR4 on Panel Sheet	1
CAPACITOR					
	01674334	ECJ1VC1H101J	CERAMIC CAPACITOR	C7,C8,C84,C12,C100,C11,C9,C94,C13,C140,C49,C152,C6,C5,C4,C3,C2,C141,C150,C48,C130,C42,C162,C47,C46,C45,C51,C43,C15,C41,C39,C38,C37,C36,C34,C32,C30,C22,C44,C35,C20 on Main board	41
	01674201	ECUV1H180JCV	CERAMIC CAPACITOR	C105,C106 on Main board	2
	01674478	ECJ1VB1H122K	CERAMIC CAPACITOR	C149,C139 on Main board	2
	01674512	ECJ1VB1H222K	CERAMIC CAPACITOR	C96 on Main board	1
	01674167	ECUV1H100DCV	CERAMIC CAPACITOR	C155,C142,C131,C124,C119 on Main board	5
	01674212	ECJ1VC1H220J	CERAMIC CAPACITOR	C102,C101 on Main board	2
	01674578	ECJ1VB1H682K	CERAMIC CAPACITOR	C170,C163 on Main board	2
	01674701	ECJ1VF1E104Z 0.1UF/16VK	CERAMIC CAPACITOR	C180,C190,C192,C178,C183,C179,C185,C186,C187,C189,C191,C182,C177,C188,C72,C76,C66,C67,C69,C64,C71,C63,C184,C21,C176,C19,C18,C17,C23,C70,C55,C24,C25,C26,C28,C40,C65,C53,C77,C56,C57,C58,C59,C60,C61,C62,C50,C129,C73,C103,C108,C110,C113,C95,C128,C92,C147,C157,C164,C172,C173,C174,C175,C118,C85,C79,C80,C81,C82,C97,C83,C78,C86,C10,C87,C1,C88,C89,C90,C91,C14 on Main board,C4,C7,C9,C2,C11,C12,C13,C5,C8 on Panel Sheet	90
	02129534	ECJ1VB1H102K	CERAMIC CAPACITOR	C181,C33,C31,C29 on Main board,C10 on Panel Sheet	5
	02900512	EEE1CA100SR	CHEMICAL CAPACITOR	C120,C27,C68,C75,C98,C99,C104,C16,C143,C109,C167,C166,C165,C160,C158,C156,C151,C146,C144,C138,C137,C126,C107,C121,C122,C145,C125,C136,C127,C132,C133,C134,C135,C123 on Main board	34
	02900523	EEE1CA101WP	CHEMICAL CAPACITOR	C161,C112,C171,C169,C115,C116,C117 on Main board,C6 on Panel Sheet	8
	03348445	EEE1CA471UP	CHEMICAL CAPACITOR	C114 on Main board	1
	03454723	EEE0JA331P	CHEMICAL CAPACITOR	C111 on Main board,C1,C3 on Panel Sheet	3
	03454889	EEE1HA010SR	CHEMICAL CAPACITOR	C154,C148,C153 on Main board	3
INDUCTOR, COIL, FILTER					
	01904001	TSL1315S-101	CHOKO COIL	L35 on Main board	1
	02780378	ELL6SH2R7M	CHOKO COIL	L34 on Main board	1
	01340834	EXCML20A390	FERRITE-BEAD	L32 on Main board	1
	01565578	N1608Z601T01	FERRITE-BEAD	L36,L37,L38,L40,L42,L43,L44,L41,L39 on Main board	9
	03121245	BLM18BD102SN1	FERRITE-BEAD	L30,L31,L29,L28,L27,L26,L25,L11,L1,L2,L8,L24,L3,L6,L7,L33,L9,L4,L5,L12,L13,L14,L15,L16,L17,L18,L19,L20,L21,L22,L23,L10 on Main board	32
	13529246	DSS310-91D223S-50ATL12-134	EMI FILTER	FL1 on Panel Sheet	1

CRYSTAL, RESONATOR					
	02673278	CX-49G 11.2896MHZ	CRYSTAL	X2 on Main board	1
#	04010578	SG-9001JC C10P 10MHZ	CRYSTAL OSCILLATOR	X3 on Main board	1
CONNECTOR					
#	02012189	40FMN-BTK-A(LF)(SN)	CONNECTOR	CN3 on Main board	1
	13369515	B5B-PH-K-S JST	CONNECTOR	CN5 on Main board	1
	13369564	B12B-PH-K-S JST	CONNECTOR	CN6 on Main board,CN2 on Panel Sheet	2
	13369665	S5B-PH-K-S(5P)	CONNECTOR	CN3 on Panel Sheet	1
#	04010589	40FMN-STK-A (LF)(SN)	CONNECTOR	CN1 on Panel Sheet	1
	13369570	B2B-PH-K-S (2P)	CONNECTOR	CN4 on Panel Sheet	1
WIRING, CABLE					
#	04015601	WIRING	W1		1
	02344001	WIRING	12X100-P2.0-PHR-PHR-F		1
#	03909045	WIRING	5X80-P2.0-PHR-PHR-F		1
#	03909056	BAN CARD	BNCD-P=1.00-K-40-100		1
SCREW					
	40230590	SCREW M3X10	BINDING MACHINE NI		1
	02126156	SCREW M3X10	HEX SOCKET HEAD CAP TAPTITE P		4
	40011112	SCREW 3X10	BINDING TAPTITE B BZC		6
	40011312	SCREW 3X8	BINDING TAPTITE P BZC		11
	40011490	SCREW M3X6	PAN MACHINE W/SW BZC		1
PACKING					
#	03908878	UPPER PAD			1
#	03908889	LOWER PAD			1
#	03908867	PACKING CASE			1
#	04019278	OUTER PACKING CASE			1
MISCELLANEOUS					
#	40672389	BATTERY CUSHION			2
	00340690	FOOT ZULEN (CUSHION)	XCK040 12MM		4
#	03908912	BATTERY TERMINAL +			1
#	03908923	BATTERY TERMINAL -			1
#	03908934	BATTERY TERMINAL +-			2
#	04120734	BATTERY TERMINAL PM			1
	03679190	MIC	WM-64PNT	MIC1 on Main board	1
	12199584	GROUNDING TERMINAL	M1698	TER1,TER2 on Panel Sheet	2
ACCESSORIES (STANDARD)					
△	03017356	AC ADAPTOR WITHOUT AC CORD	PSB-1U(R) UNIVERSAL		1
△	01903334	AC CORD SET	100V	1.0M FOR PSB-1U	1
△	02562456	AC CORD SET	120V	1.0M (NON POLAR)	1
△	01903356	AC CORD SET	230V EU	1.0M FOR PSB	1
△	00905234	EURO CONVERTER PLUG	ECP01-5A		1
	*****	AC CORD	230V E	CORD(#01903356) + PLUG(#00905234)	
△	03785590	AC CORD SET	240V A	SC-078-NA05	1
#	73016067	OWNER'S MANUAL	JAPANESE (OPTION)		1
#	73017212	OWNER'S MANUAL	ENGLISH		1

CHECKING THE VERSION NUMBER

1. Turn on the power.
2. Simultaneously hold down the [MARK] switch and press the [POWER] switch.
3. The version is indicated in the display.
 - * Ver 1.01 is indicated in the 7'SEG LED as "101".

USERS DATA SAVE AND LOAD

Saving Backup Data (Backup Save)

Here's how to save backup data (all of the SP-404's data including sample banks and pattern banks) to a memory card. You can save up to twelve sets of backup data.

NOTE

If the card runs out of free space because you save large amounts of sample or pattern data, the number of backup sets that can be saved will be fewer.

1. Insert a memory card formatted for the SP-404 in the SP-404 and turn on the power.
2. Hold down [CANCEL] and press one of the BANK [C/G]-[F/J] buttons. "SAV(SAU)" appears in the display and pads for which backup data has not been saved begin blinking.
3. Select one of the flashing pads as the save destination pad. The selected pad remains lit, and the other pads stop flashing and remain off. [REC] flashes.
4. Press [REC].

[REC] lights, and the Backup Save operation begins. The dot in the display will blink while the operation is in progress.

When saving is complete, the blinking will stop.

NOTE

Never turn off the power while the dot is blinking. Doing so may damage the backup data or the memory card.

5. Turn off the power and keep the memory card safely stored.

Loading Backup Data (Backup Load)

Here's how to load backup data (all of the SP-404's data including sample banks and pattern banks) from a memory card.

NOTE

When you execute the Backup Load operation, the internal settings of the SP-404 will be erased and replaced by the backup data you loaded.

Backup Load cannot be performed if data protect is in effect. Before starting the procedure, hold down [CANCEL] and turn on the power to cancel data protection

1. Insert the memory card containing the backup data in the SP-404 and turn on the power.
2. Hold down [CANCEL] and press BANK [A] or [B].

"Lod" appears in the display and the pads for which backup data has been saved begin blinking.

NOTE

If the Protect setting is enabled, "Prt" (Protected) appears in the display, and you will be unable to execute the Backup Load operation.

3. Press a pad to select the backup data that you want to load.

The selected pad lights, and the other pads stop blinking. [REC] begins blinking.

MEMO

You can't select a pad that was dark in step 2 (i.e., a pad for which no data has been saved). If you decide to cancel the operation at this point, press [CANCEL].

4. Press [REC].

[REC] lights, and the Backup Load operation begins. The dot in the display will blink while the operation is in progress. When loading is complete, the blinking will stop.

NOTE

Never turn off the power while the dot is blinking. Doing so may damage the backup data or the memory card.

Instructions for System Initialize

Factory Settings Cannot Be Restored with SP-404 Alone

Once samples or patterns assigned at the factory have been deleted or changed, the SP-404 factory settings cannot be restored using the instrument itself. To return the SP-404 to its factory settings, obtain the SERVICE DATA & PROGRAM CD-ROM (#17041673) and after confirming the service information, create an "initialization memory card" and proceed with the initialization.

Main Process

1. Connect the memory card formatted for the SP-404 to the computer.
2. Copy the data on the SERVICE DATA & PROGRAM CD-ROM through the computer to the initialization memory card.
3. Connect the memory card with the data copied to it to the SP-404 and restore the SP-404's settings.

* For more detailed instructions, refer to the following pages.

Required Equipment

1. SP-404 SERVICE DATA & PROGRAM CD-ROM (#17041673)
 - * Confirm the service information.
2. Computer equipped with CD-ROM drive and CompactFlash reader/writer
3. Memory card (CompactFlash, minimum 32 MB capacity)

Instructions for Creating the Initialization Memory Card

Format the memory card on the SP-404.

NOTE

Formatting the memory card erases all data on the card.

1. Hold down [CANCEL] and press [REMAIN]. BANK [C/G]-[F/J] flash, and "FMT" appears in the display.
2. Press any BANK button [C/G]-[F/J]. BANK [C/G]-[F/J] stop flashing and remain lit; [DEL] flashes (to cancel the formatting, press [CANCEL]).
3. Press [DEL]. [DEL] lights up, and formatting is executed. The dot in the display flashes while formatting is in progress. Formatting is completed when the flashing stops.
4. This completes formatting of the initialization memory card. Turn off the power to the SP-404 and eject the memory card.

NOTE

Never turn off the power while the dot is blinking. Doing so may damage the backup data or the memory card.

Do not alter or delete any of the files or folders created on the formatted memory card.

Doing so will result in the card failing to be recognized properly by the SP-404.

Copy the required data to the memory card.

1. Insert the memory card in the computer's CompactFlash reader/writer.
2. Place the SP-404 SERVICE DATA CD-ROM in the computer's CD-ROM drive.
3. Copy the "\FCTRY" folders on the SP-404 SERVICE DATA CD-ROM individually to the "\ROLAND" folder on the memory card.
4. Remove the memory card from the card reader.
5. The initialization memory card is now ready.

Instructions for Restoring the Factory Settings

* Create an "initialization memory card" before beginning this procedure.

1. Turn off the power to the SP-404.
2. Insert the initialization memory card in the SP-404.
3. Simultaneously hold down [DEL], [CANCEL], and [REMAIN] and turn on the power to the SP-404. "ini" appears in the display, and [REC] flashes.
4. Press [REC] to begin the initialization. The dot in the display flashes while initialization is in progress.
5. When all processing is completed, "ini" disappears from the display (and normal operation begins).
6. Turn off the power to the SP-404.

SYSTEM UPDATE INSTRUCTIONS

Required Equipment

1. SP-404 SERVICE DATA & PROGRAM CD-ROM (#17041673)
Confirm the service information.
2. Computer equipped with CD-ROM drive and CompactFlash reader/writer
3. Memory card (CompactFlash, minimum 32 MB capacity)

System Update Procedure

Creating the Updater Memory Card

1. Format a memory card on the SP-404.
2. Turn off the power to the SP-404 and eject the memory card.

Copy the required data to the memory card.

1. Insert the memory card in the computer's CompactFlash reader/writer.
2. Place the SP-404 SERVICE DATA CD-ROM in the computer's CD-ROM drive.
3. Copy the DCOAPL.BIN file in the "UPDATE" folder on the SP-404 SERVICE DATA CD-ROM to the memory card's root folder.

NOTE

Do not copy the individual UPDATE folder.

Copy only the DCOAPL.BIN file to the root folder.

4. The data is copied to the memory card. Remove the memory card from the card reader.

Update Instructions

1. Turn off the power to the SP-404.
2. Insert the updater memory card in the SP-404.
3. Turn on the power to the SP-404; the update begins automatically.
 - * While the update is in progress, the pads light in sequence and the amount of processing remaining to complete (100-0) is indicated in the display. All processing is completed when "000" is indicated in the display.
4. Turn off the power to the SP-404 and remove the updater memory card.
5. Check the version number to confirm that the update has been executed properly.
6. Turn off the power to the SP-404 to finish the operation.

If the System Update Fails

If the System Update fails, turn off the SP-404's power off and then on again, then perform the update again.

If the update cannot be completed successfully on the second attempt, it is highly likely that the memory card was not correctly prepared; recreate the updater memory card.

If unable to update the system even after these steps, replace the MAIN board.

TEST MODE

Backing Up the User Data

All user data is deleted when Test mode is carried out. Also be sure to reload the user data after competing Test mode.

Required Equipment

1. SP-404 SERVICE DATA & PROGRAM CD-ROM (#17041673)
2. Computer equipped with CD-ROM drive and CompactFlash reader/writer
3. 2 memory cards (CompactFlash, minimum 32 MB capacity). In the instructions that follow, these are referred to as the backup memory card and test memory card.
4. MIDI Cable
5. Audio Cable
6. MIDI device (UM-1, MC-909, Fantom, V-Synth, or other MIDI device that transmits Active Sensing)
7. MIC
8. Oscillator or similar device (for input of audio signals)
9. Oscilloscope, speakers (for confirming output audio signals)

Setup

First create a test memory card and insert it in the SP-404, connect all required cables, then carry out the following preparations before entering Test mode.

Creating the Test Memory Card



The following tests cannot be performed without a test memory card.

- Memory Card Check (performed during the automatic checks)
- Demo Play

(Tests other than those listed above can be performed without a test memory card.)

1. Format the test memory card with the SP-404 (refer to the instructions for initializing the system).
2. Turn off the power to the SP-404, and eject the test memory card from the SP-404.
3. Insert the test memory card in the computer's CompactFlash reader/writer.
4. Place the SP-404 SERVICE DATA CD-ROM in the computer's CD-ROM drive.
5. Copy the "\FCTRY" folder on the SP-404 SERVICE DATA CD-ROM separately to the "\ROLAND" folder on the test memory card.
6. Eject the test memory card from the CompactFlash reader/writer.
7. Prepare to enter Test mode in reference to the following procedures.

Insert the memory card and connect the cables.

1. Insert the test memory card in the memory card slot.
2. Connect a MIDI device that transmits Active Sensing (e.g., UM-1, MC-909, Fantom, V-Synth, etc.) to MIDI IN.
3. Input an audio signal to LINE IN L/R with an oscillator or other such device.
4. Enable the oscilloscope or similar device to measure signals from LINE OUT L/R.
5. Connect a mic to the MIC jack.
6. Set the MIC LEVEL volume to maximum.
7. This completes preparations for Test mode. Refer to "Entering Test Mode" and proceed with testing.

Entering Test Mode

1. Turn off the power to the SP-404.
2. Insert the test memory card in the memory card slot.
3. Simultaneously hold down [PITCH], [VINYL SIM], and [HOLD] and turn on the power to the SP-404. "tSt" appears in the display, and the SP-404 automatically begins Test mode (with 1. Device Check).
 - * the Device check is completed without error, the display changes to "Lin."

Exiting Test Mode

Turn off the power.

Selecting the Test Category

The following procedure can be used to select individual test categories during Test mode.

Procedure	Test Mode
Hold down [TAP TEMPO] and press [1]	Device Check
Hold down [TAP TEMPO] and press [2]	Input/Output Jack Check (LINE IN, LINE OUT, PHONES)
Hold down [TAP TEMPO] and press [3]	Mic Check
Hold down [TAP TEMPO] and press [4]	Switch/LED Check
Hold down [TAP TEMPO] and press [5]	Volume Check
Hold down [TAP TEMPO] and press [6]	Demo Play Check
Hold down [TAP TEMPO] and press [7]	Residual Noise Check

Test Categories

Start Test mode. Refer to "Entering Test Mode."

1. Device Check

"tSt" appears in the display, and all 11 categories are checked automatically. If all tests are passed without error, the procedure automatically advances to "2. Input/Output Jack Check."

If any test fails, the corresponding item is indicated with the PAD LEDs (the procedure does not automatically advance to the next test).

PAD	Problem	Items to check
[1]	VERSION	Update the system.
[2]	CPU ROM	Confirm that the CPU (IC2) is properly installed.
[3]	CPU RAM	Confirm that the CPU (IC2) is properly installed.
[4]	NOR FLASH	Confirm that the NOR FLASH MEMORY (IC8) is properly installed.
[5]	NAND FLASH	Confirm that the NAND FLASH MEMORY (IC6) is properly installed.
[6]	SDRAM	Confirm that the SDRAM (IC3) is properly installed.
[7]	DSP	Confirm that the DSP (IC10) is properly installed.
[8]	Compact Flash	Confirm that (IC11, CN1) are properly installed.
[9]	MIDI	Confirm that (IC23) is properly installed.
[10]	AUDIO DEVICE	Confirm that the DSP (IC10) and GA (IC4) are properly installed.
[11]	DEMO DATA	Confirm that the test CF has been properly created.

2. Input/Output Jack Check (LINE IN, LINE OUT, PHONES)

"Lin" appears in the display.

Audio signals input to LINE IN are output by the SP-404 to LINE OUT and PHONES.

Check the signals from LINE OUT and PHONES.

If there is no problem with the signals, disconnect the cable from LINE IN L/R; the e procedure automatically advances to "3. Mic Check."

3. Mic Check

"MiC" appears in the display.

Audio signals input to MIC are output by the SP-404 to LINE OUT and PHONES.

Check the signals from LINE OUT and PHONES.

1. MIC LEVEL

Set this to the maximum level.

2. External Mic

Input sounds to the mic connected to the MIC jack and check the signals from LINE OUT (or PHONES).

If there is no problem with the signals, disconnect the cable from the MIC jack.

3. Internal Mic

Input sounds to the internal mic and check the signals from LINE OUT (or PHONES).

4. MIC LEVEL

If there is no problem with the signals, rotate the MIC LEVEL knob and check to confirm that the level changes properly..

If there is no problem with the knob, press the [MIC] button; the procedure automatically advances to "4. Switch/LED Check."

4. Switch/LED Check

1. Display Illumination

Check visually and note whether the illumination lighting the area around the display (the red LEDs) light, both above and below.

2. Seven-Segment LEDs

Check visually and note whether the seven-segment LED display lights in the sequence.

3. Switch/LED

Press the buttons with lit LEDs in sequence.

There is a total of 45 switches, with the LEDs lighting in the following sequence.

* All of the LEDs light when the buttons up to [MIC] have been pressed.

4. PEAK

Confirm that the PEAK LED is lit, then proceed to press the following button in sequence given (the following buttons do not have LEDs).

[TAP TEMPO] -> [CANCEL] -> [REMAIN] -> [SUB PAD]

Buttons without LEDs are indicated in the display as shown below.

"tAP" : [TAP TEMPO]

"CAr" : [CANCEL]

"rEN" : [REMAIN]

"SUB" : [SUB PAD]

5. If all of the switches operate properly, the procedure automatically advances to "5. Volume Check."

5. Volume Check

1. CTRL 1

Rotate the [CTRL 1] knob from the minimum value (left) to the maximum value (right).

The value indicated in the seven-segment display (left column) changes in accordance with the movement of the knob; the dot lights if the test is passed.

If an incorrect value is detected, the procedure returns to the beginning of "5. Volume Check."

2. CTRL 2

Rotate the [CTRL 2] knob from the minimum value (left) to the maximum

value (right).

The value indicated in the seven-segment display (center column) changes in accordance with the movement of the knob; the dot lights if the test is passed.

If an incorrect value is detected, the procedure returns to the beginning of "5. Volume Check."

3. CTRL 3

Rotate the [CTRL 3] knob from the minimum value (left) to the maximum value (right).

The value indicated in the seven-segment display (right column) changes in accordance with the movement of the knob; the dot lights if the test is passed.

If an incorrect value is detected, the procedure returns to the beginning of "5. Volume Check."

If the check finishes without error, the procedure automatically proceeds to "6. Demo Play Check."

6. Demo Play Check



Demo Play cannot be performed without a test memory card inserted in the memory card slot.

The demo song plays automatically.

Confirm that the demo song is played correctly.

Rotate the [VOLUME] knob and confirm that the volume level changes properly.

After confirming the above, press [MIC]; the procedure automatically proceeds to "7. Residual Noise Check."

7. Residual Noise Check

Set [VOLUME] to maximum and check the residual noise.

If there is no problem, turn off the power to the SP-404.

8. Backup Load



Following Test mode, all user data is erased.

After completing Test mode, reload the previously saved user data to the SP-404.

Test mode is finished once the user data is completely loaded.

BLOCK DIAGRAM

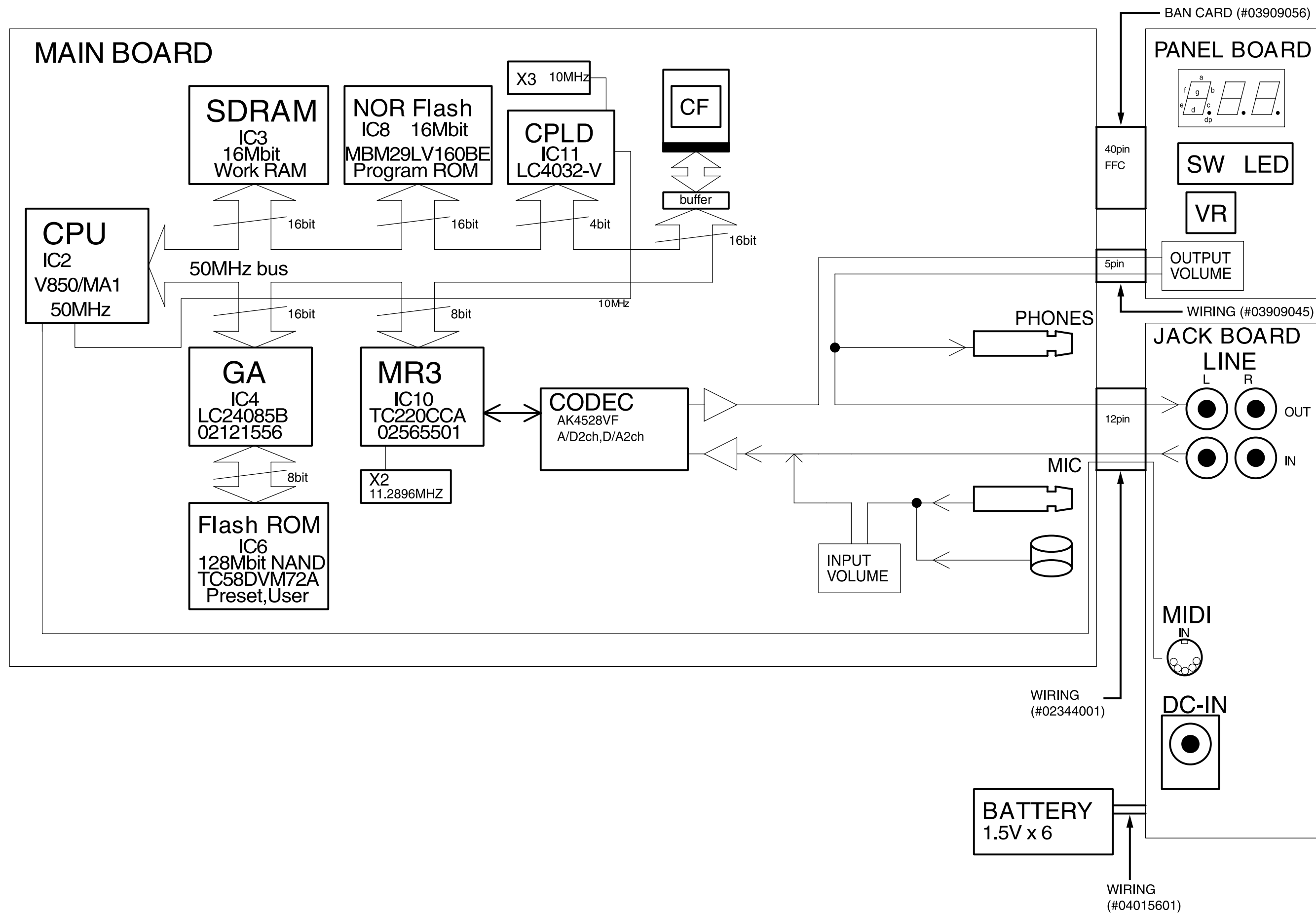

CIRCUIT BOARD (MAIN BOARD)

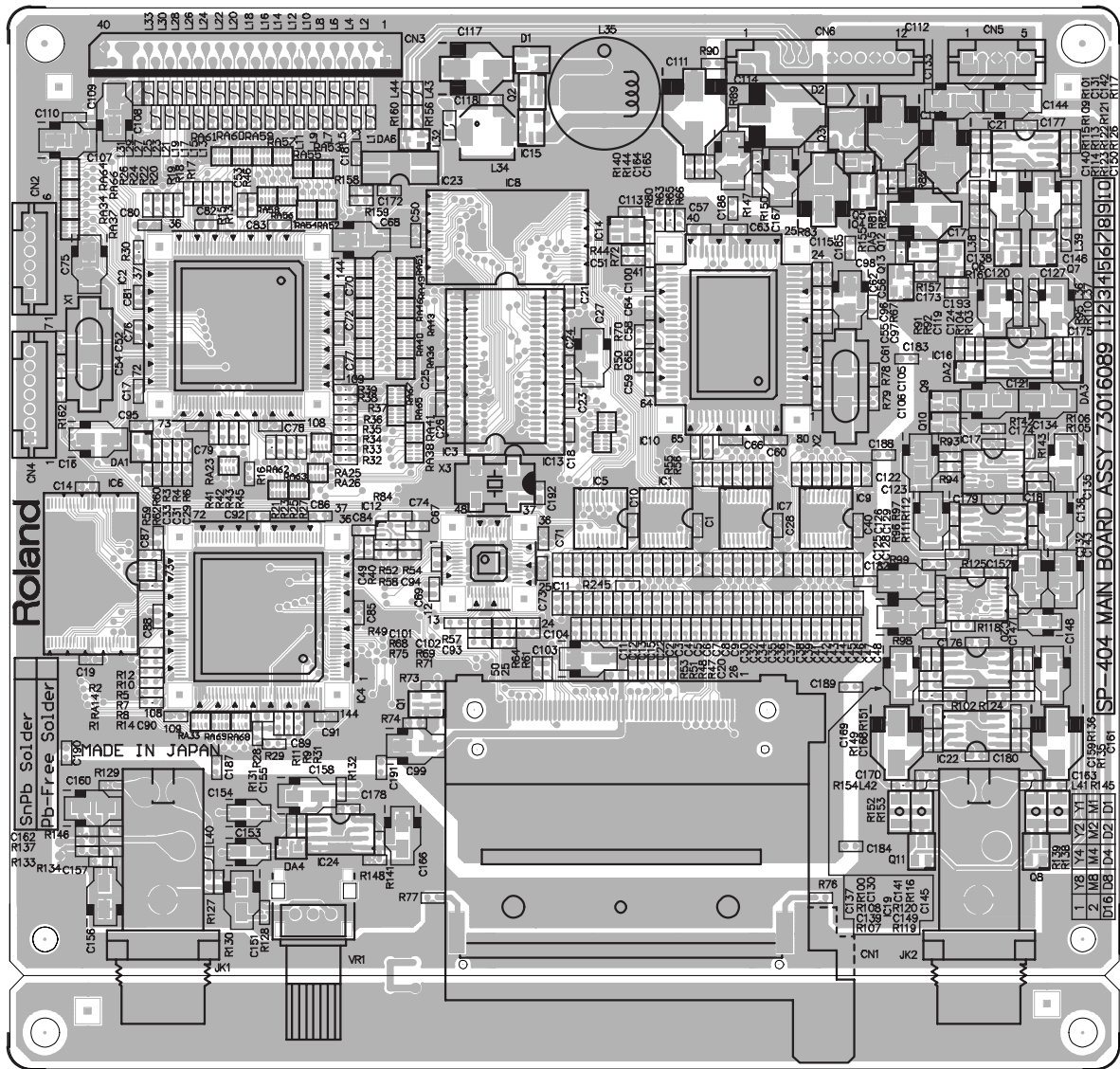

View from components side
"scale=1.00"

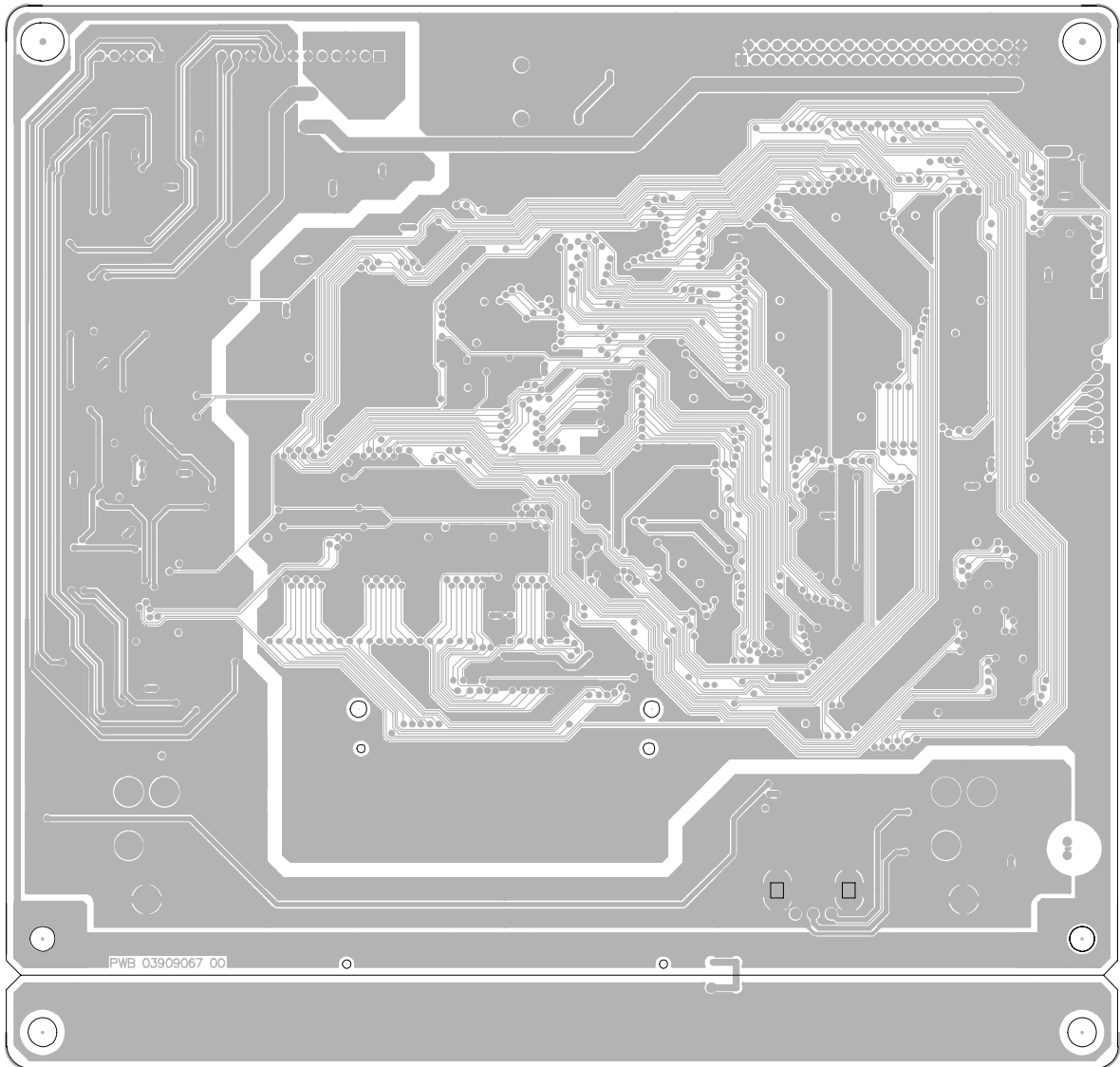

View from foil side
"scale=1.00"

CIRCUIT DIAGRAM (MAIN BOARD DIGITAL)

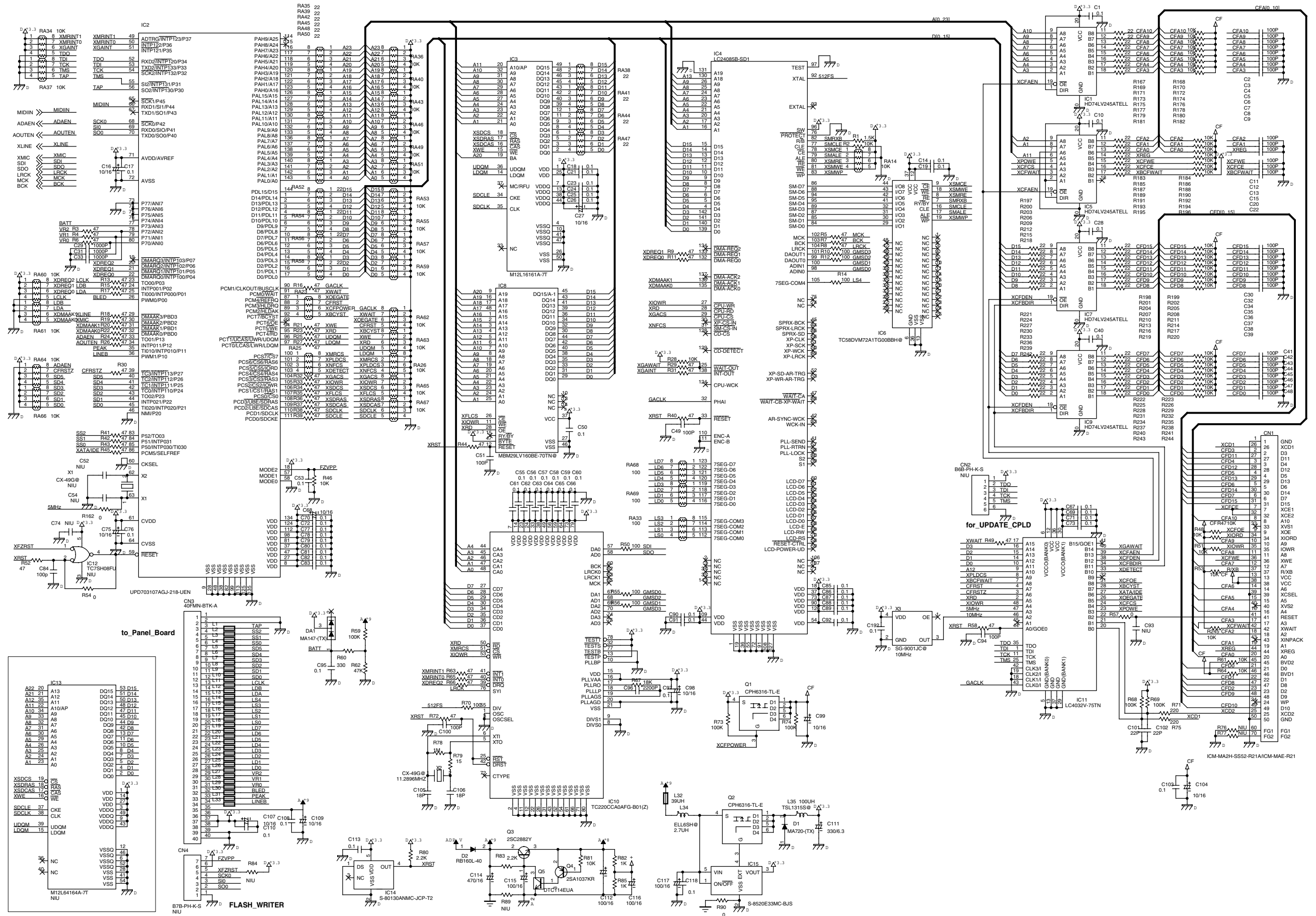

CIRCUIT DIAGRAM (MAIN BOARD ANALOG)

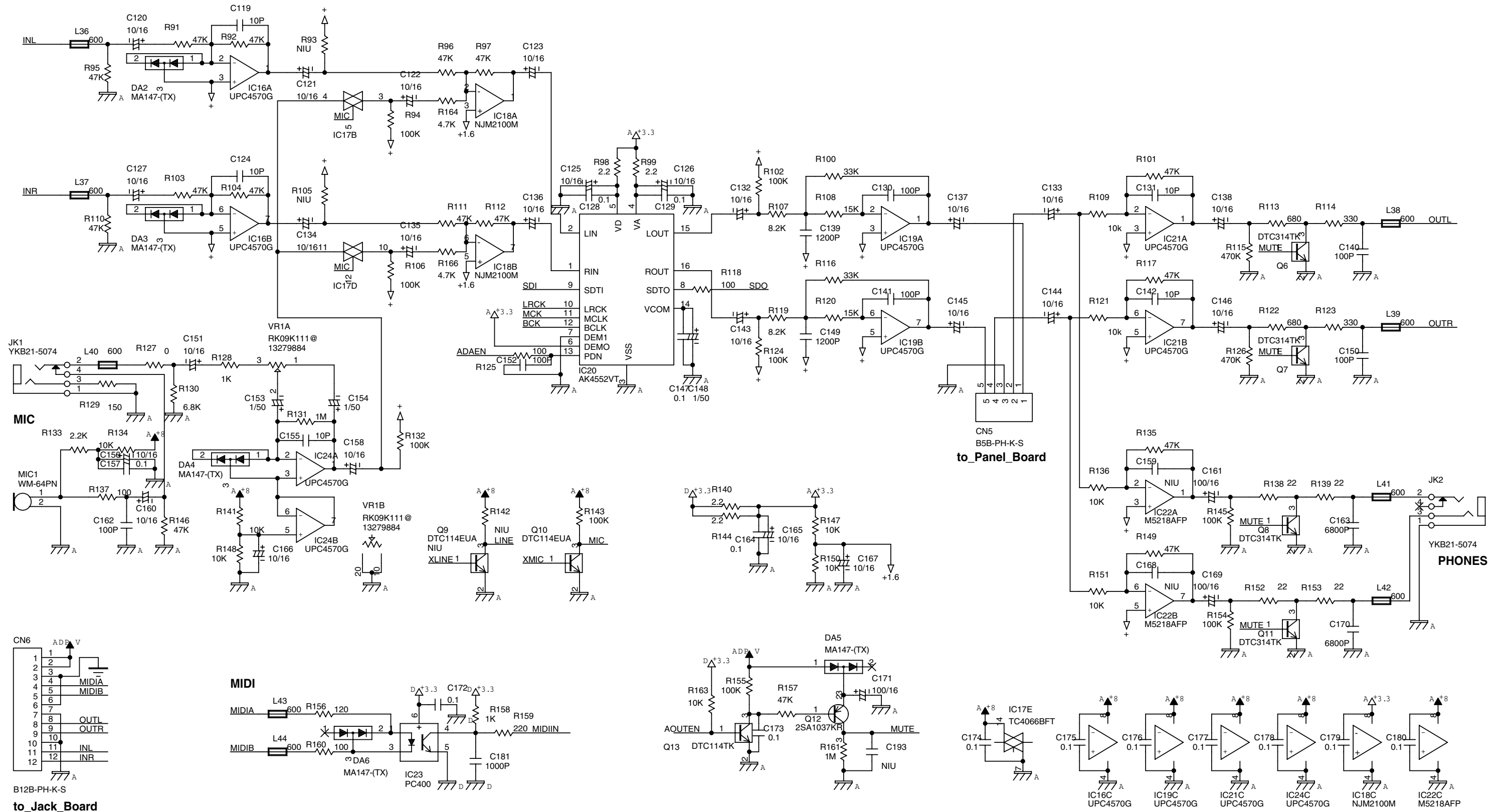

- MIDIIN >>> MIDIIN
- ADAEN <<< ADAEN
- AOUTEN <<< AOUTEN
- XLINE <<< XLINE
- XMIC <<< XMIC
- SDI <<< SDI
- SDO <<< SDO
- LRCK <<< LRCK

C182	0.1
C183	0.1
C184	0.1
C185	0.1
C186	0.1
C187	0.1
C188	0.1
C189	0.1
C190	0.1
C191	0.1

CIRCUIT BOARD (PANEL BOARD, JACK BOARD)

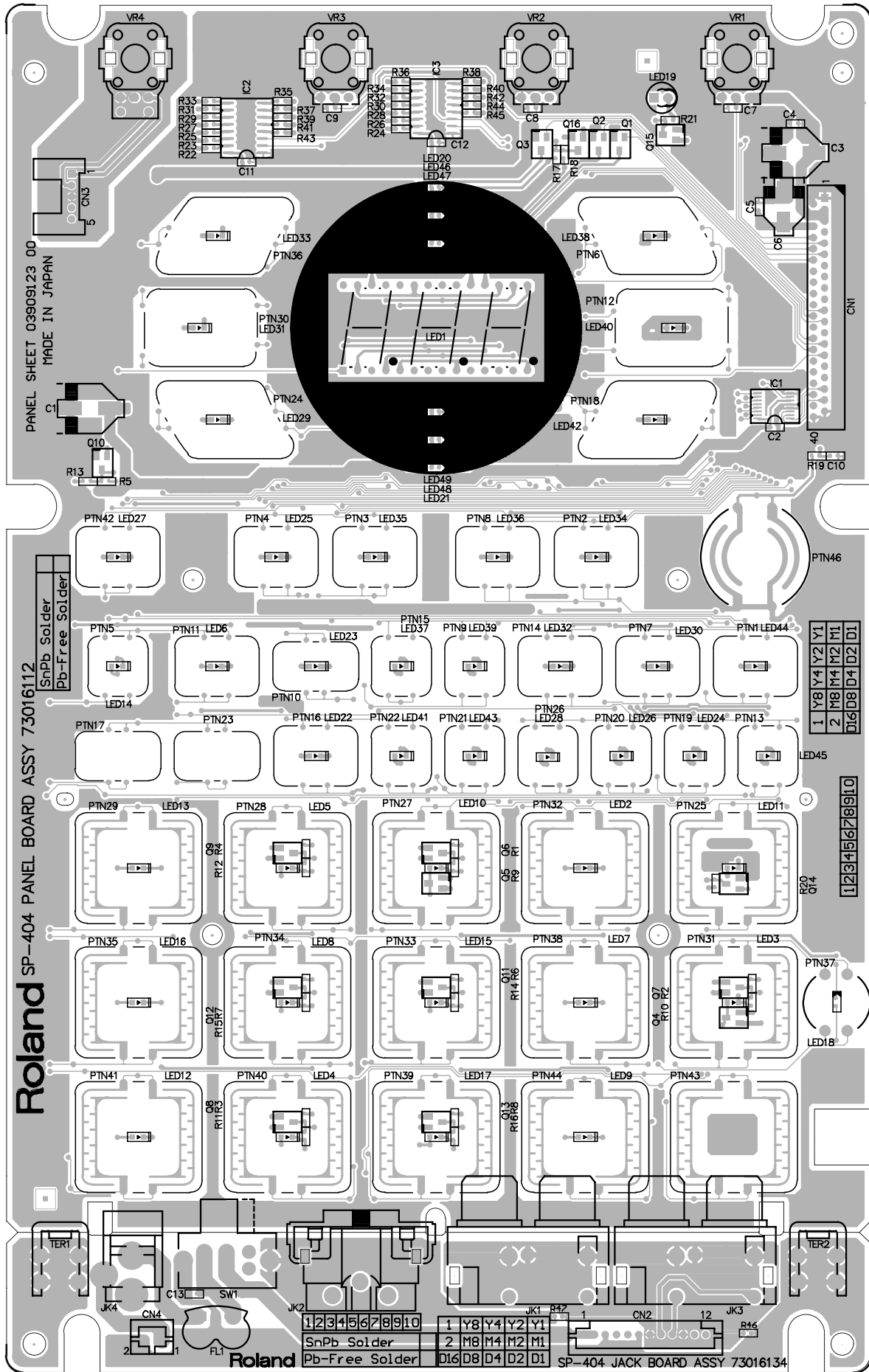

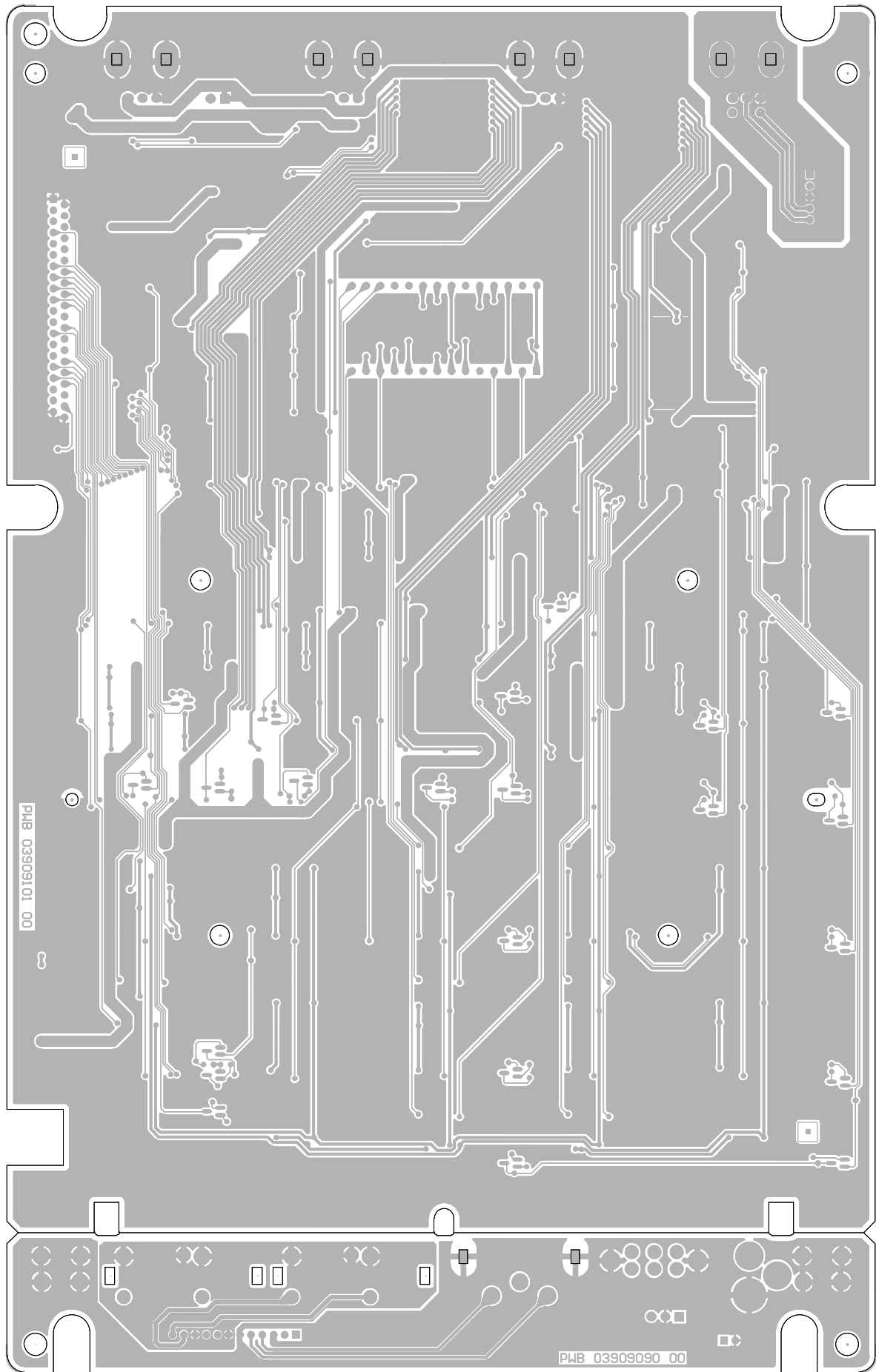

CIRCUIT DIAGRAM (PANEL BOARD, JACK BOARD)

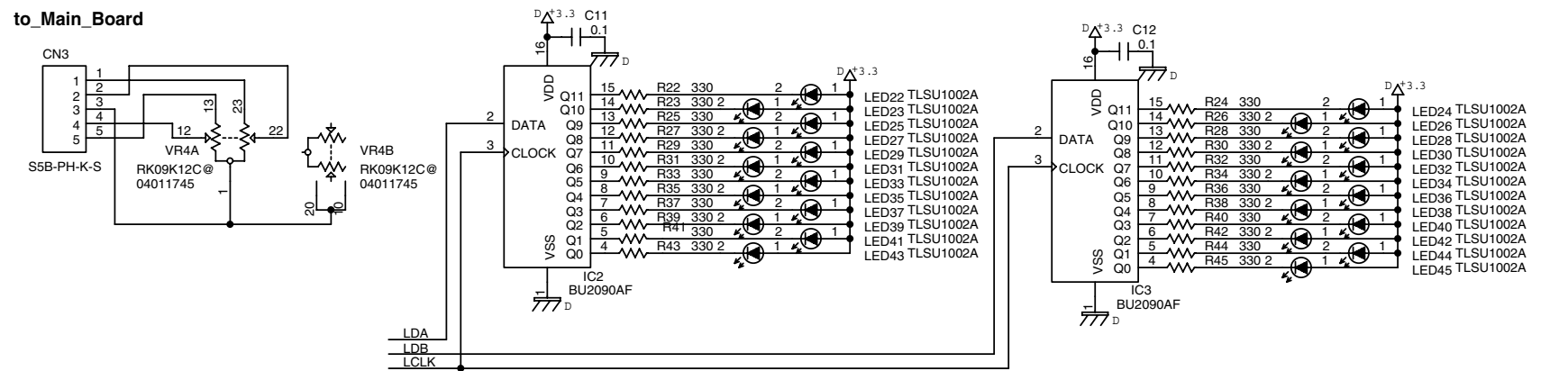
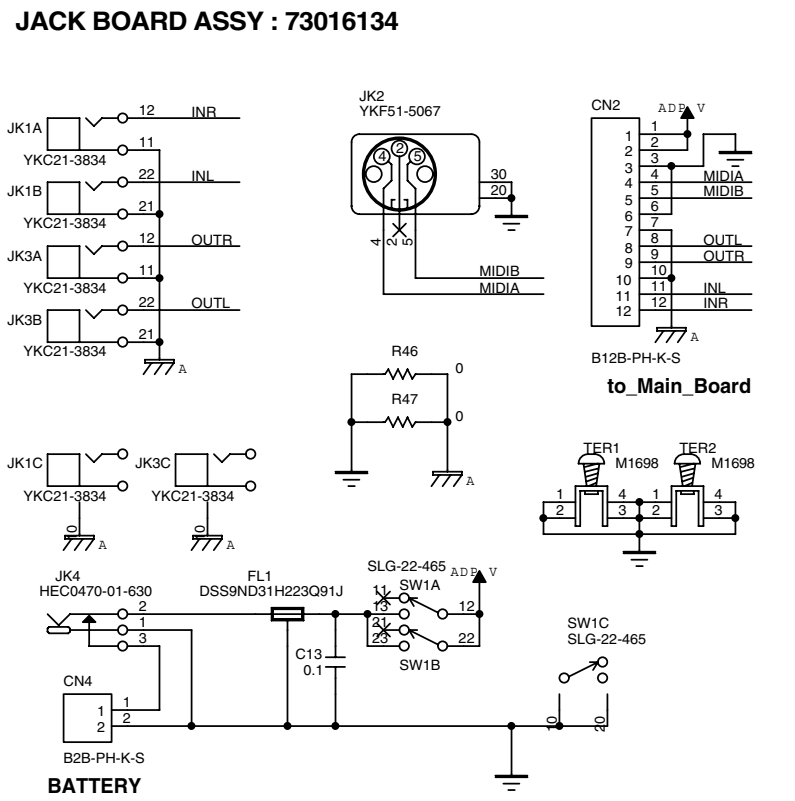
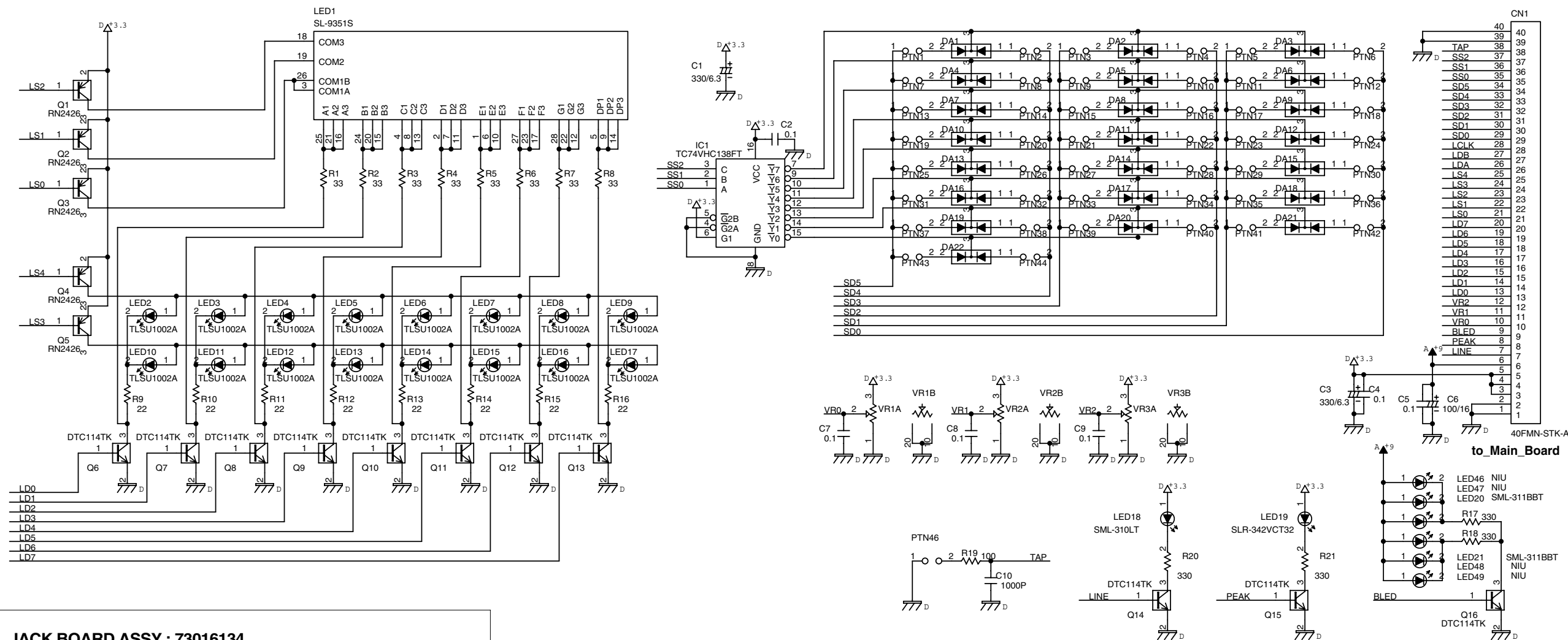

ERROR MESSAGES

Message	Meaning
A.on (Bank A protect on)	Bank A is protected.
AiF (AIFF)	Audio files will be exported in AIFF format.
bdL (Backup Delete)	Backup data will be deleted.
CHG (Change)	Samples or patterns will be exchanged between two pads.
dAL (Delete All)	All samples or patterns in the bank will be deleted.
dEL (Delete)	The sample or pattern will be deleted.
Edt (Edit)	The sample is being edited.
EJC (Eject)	The memory card was removed, so processing is not possible. * Don't remove the card while the power is on.
EMP (Empty)	There is no sample, pattern, or backup data to delete. There is no backup data to load. There is no WAV or AIFF data to import. There is no data to export as WAV or AIFF.
Err (Error)	Faulty data was found in internal memory; it has been repaired or deleted.
ErS (Erase)	Data will be erased from the pattern.
EXP (File Export)	The sample will be exported as WAV or AIFF.
FiL (File I/E)	WAV or AIFF data will be imported/exported.
FmT (Format)	Memory card will be formatted.
FUL (Memory Full)	Processing could not be executed because there is insufficient memory.
iMP (File Import)	WAV or AIFF data will be imported.
ini (Initialize)	All data will be initialized.
L.oF (Limit mode off)	Effect Limit mode is off.
L.on (Limit mode on)	Effect Limit mode is on.
LEd (LED)	The blinking speed of the display illumination will be specified.
LEV (Level)	The resampling volume (level) will be specified.
Lo (Battery Low)	If the batteries run down completely, no further operations will be possible. Replace the batteries immediately.
Lod (Backup Load)	Backup data will be loaded.
Mid (MIDI)	Synchronized to MIDI Clock.
P.oF (Protect off)	Protect is turned off.
P.on (All data protect on)	All banks are protected.
Prt (Protected)	The operation cannot be performed because Protect is enabled.
Ptn (Pattern)	Pattern playback or recording will be performed.
rdy (Ready)	Waiting for input signal during Auto Sampling.
rEC (Recording)	Sampling. Resampling. Recording a pattern.
rEh (Rehearsal)	Rehearsal mode during pattern recording.
S.oF (Send/Return mode off)	Send/Return mode is off.
S.on (Send/Return mode on)	Send/Return mode is on.
SAV (Backup Save)	Backup data will be saved.
trC (Truncate)	Sample will be truncated.
UnS (Unsupported format)	The operation was cancelled because the WAV or AIFF is in a format not supported by the SP-404.
WAV	When exporting an audio file, it will be exported in WAV format.