

Location of Controls

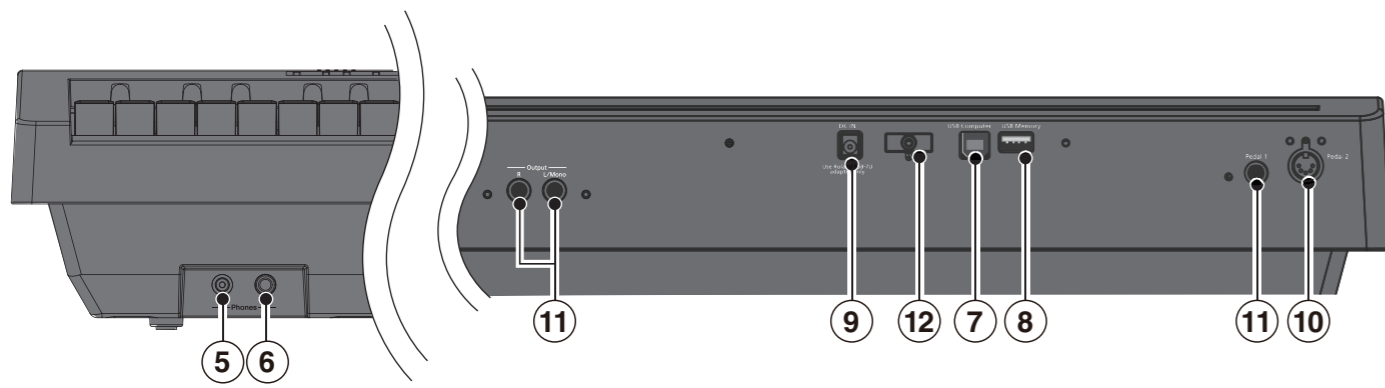
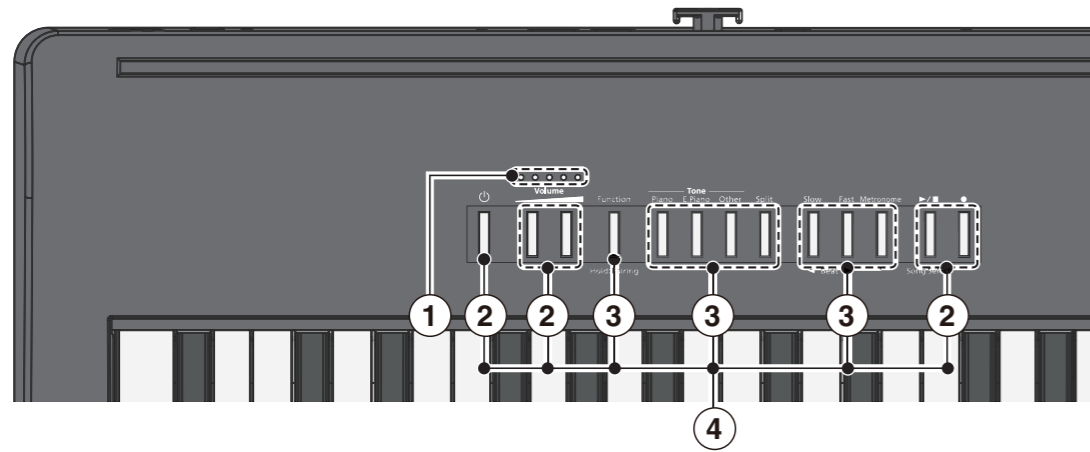

Location of Controls Parts List

No.	Part Code	Part Name	Description	Q'ty
1	5100047918	LED INDICATOR		1
2	5100047913	KEYTOP	MX2H CLR	3
3	5100047917	KEYTOP	MX4H CLR	2
4	01458501	TACT SWITCH	SKQMAK	13
5	04452945	3.5MM JACK	YKB21-5344N	1
6	5100071299	6.5MM JACK	YKB21-5006W	1
7	5100009531	USB CONNECTOR B TYPE FEMALE	YKF45-0044N	1
8	04459190	USB CONNECTOR A TYPE FEMALE	YKF45-0033N	1
9	5100068814	DC JACK	DC-021H-1-G	1
10	00340223	DIN SOCKET	YKF51-5031	1
11	13449275	6.5MM JACK	YKB21-5074	3
12	5100027106	CORD HOOK	40516-014	1

Exploded View

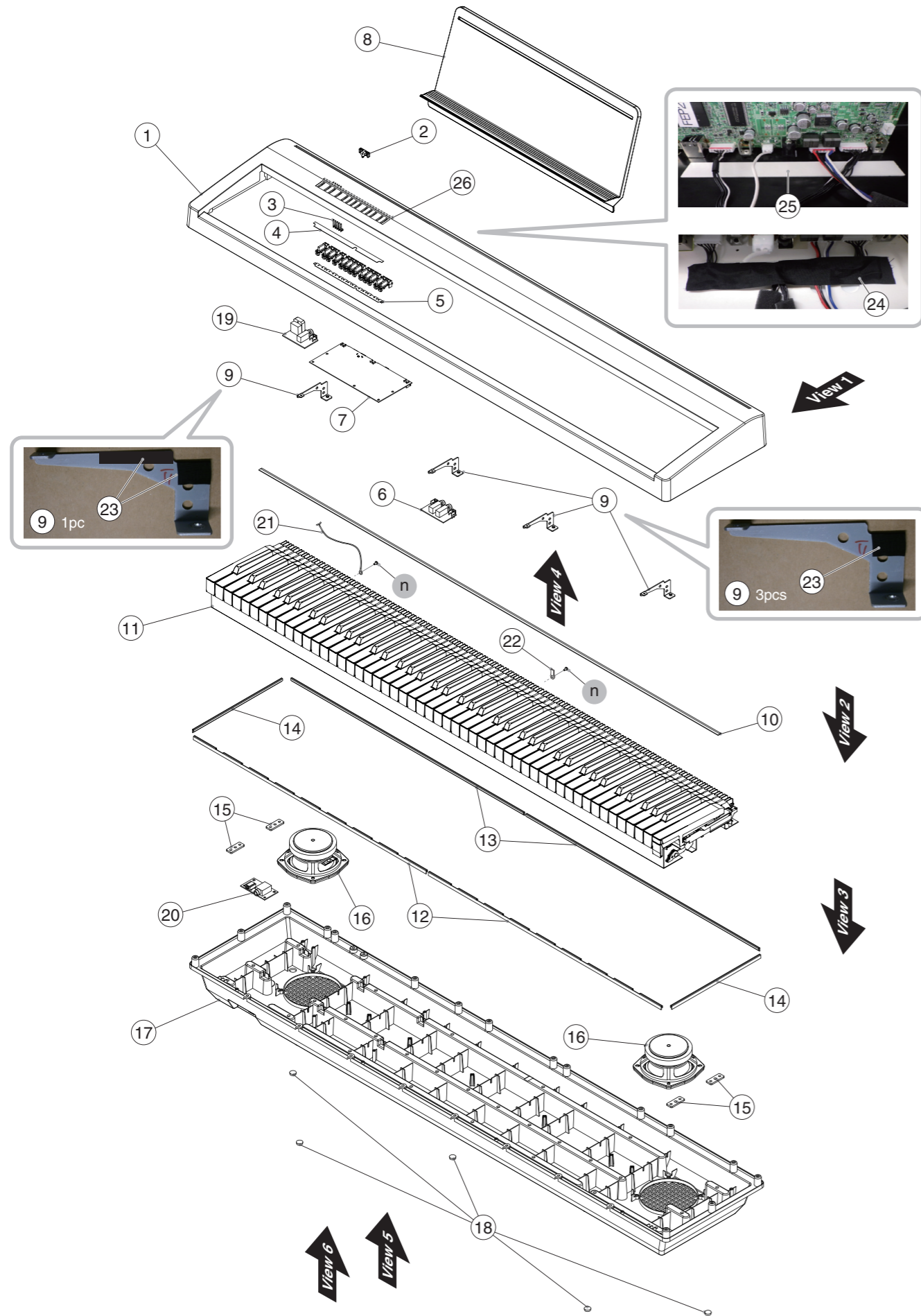

Exploded View Parts List

No.	Part Code	Part Name	Description	Q'ty
1	5100068961	TOP CASE	for BK	1
	5100068962	TOP CASE	for WH	1
2	5100027106	CORD HOOK	40516-014	1
3	5100047918	LED INDICATOR		1
4	5100048657	KEYTOP CUSHION		1
5	5100048658	TACT SW CUSHION		1
6	5100068213	OUTPUT BOARD ASSY		1
7	5100068208	MAIN BOARD ASSY		1
8	5100069603	MUSIC REST	BK for BK	1
	5100069610	MUSIC REST	WH for WH	1
9	5100047911	CENTER HOLDER		4
10	5100052508	KEY FELT		1
11	5100054674	KEYBOARD ASSY	PX-7C SV SERVICE ASSY	1
12	5100049095	CUSHION A		2
13	5100049096	CUSHION B		2
14	5100049097	CUSHION C		2
15	5100047922	SCREW HOLDER		4
16	5100047143	SPEAKER	F1204-E34C	2
17	5100047920	BOTTOM CASE	for BK	1
	5100070076	BOTTOM CASE	for WH	1
18	5100049094	FOOT	SJ-5012 BLK	5
	5100047904	JACK SHEET ASSY		1
	* This unit includes the following parts.			
19	*****	PEDAL BOARD		1
20	*****	PHONES BOARD		1
21	5100072104	WIRING	W4 (MAIN-KEYFRAME)	1
22	40016545	LOCKING TOOL FOR INSULOK TIE	SKM-1	1
23	40122789	ACETATE TAPE	NITTO #156A W15MM 30M	-
24	40232123	ACETATE TAPE	NITTO #5 BLACK W20MM 30M	-
25	40567623	DOUBLE-FACED TAPE	#575 W15MM 30M	-
26	5100021076	DOUBLE SIDED ADHESIVE TAPE	NITTO #5000NS W5MM	-
n	40011056	SCREW 3X6	BINDING TAPTITE B ZC	2

Plain View (1)

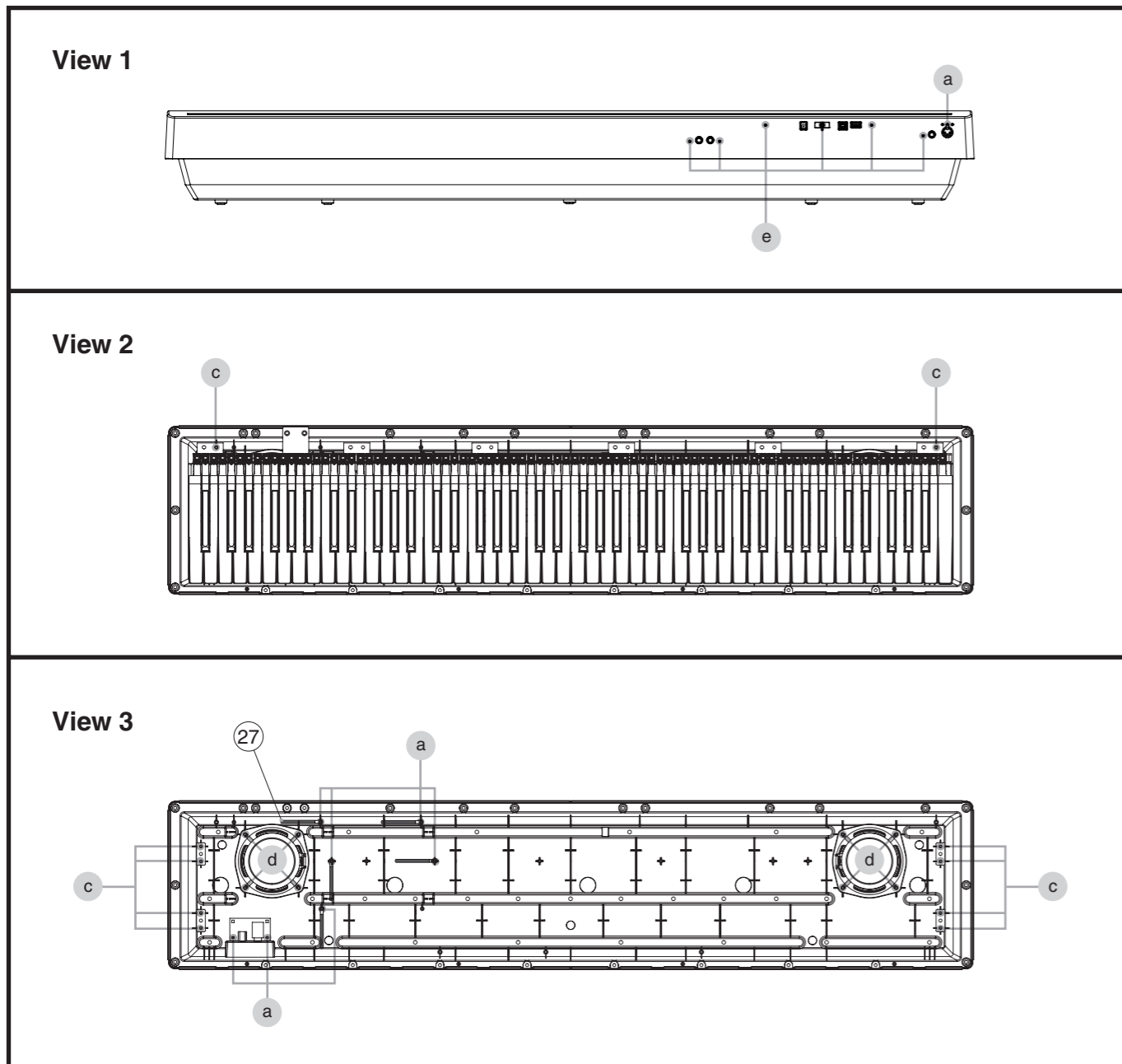

View 1

No.	Part Code	Part Name	Description	Q'ty
a	40011312	SCREW 3X8	BINDING TAPTITE P FE BZC	1
e	40459534	SCREW M3X10	PAN MACHINE W /SW+PW BZC	6

View 2

No.	Part Code	Part Name	Description	Q'ty
c	40012490	SCREW 4X10	BINDING TAPTITE P BZC	2

View 3

No.	Part Code	Part Name	Description	Q'ty
a	40011312	SCREW 3X8	BINDING TAPTITE P FE BZC	7
c	40012490	SCREW 4X10	BINDING TAPTITE P BZC	8
d	5100047746	SCREW 4X14	BINDING TAPTITE P BZC	8
27	40017378	COATING CLIP	CS-7	5

Plain View (2)

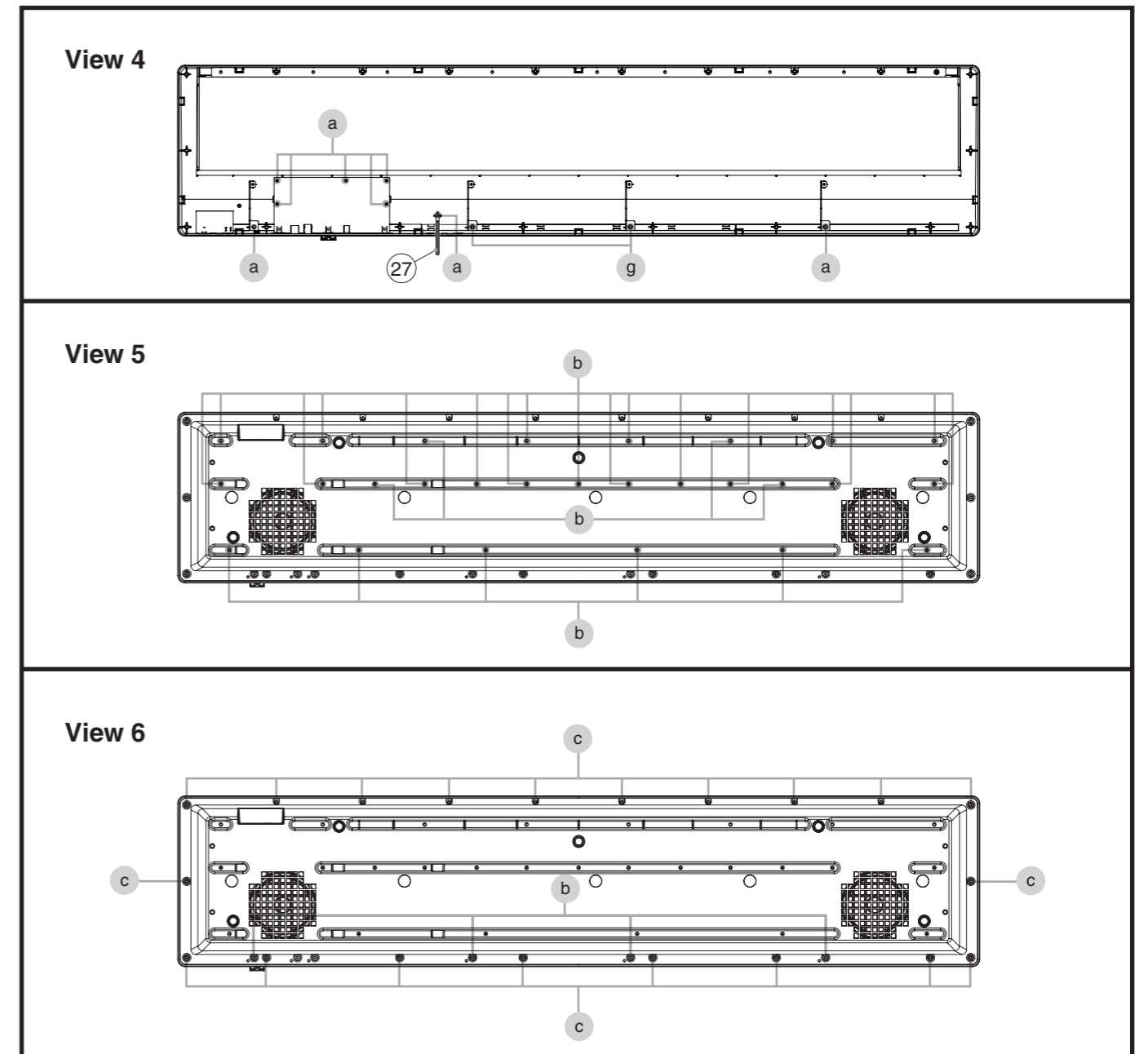

View 4

No.	Part Code	Part Name	Description	Q'ty
a	40011312	SCREW 3X8	BINDING TAPTITE P FE BZC	8
g	40011289	SCREW 3X10	BINDING TAPTITE P FE ZC	2
	5100059056	RESIN WASHER	3.2X8X1.5	2
27	40017378	COATING CLIP	CS-7	1

View 5

No.	Part Code	Part Name	Description	Q'ty
b	40012301	SCREW 4X8	BINDING TAPTITE B FE ZC	27

View 6

No.	Part Code	Part Name	Description	Q'ty
b	40012301	SCREW 4X8	BINDING TAPTITE B FE ZC	4
c	40012490	SCREW 4X10	BINDING TAPTITE P BZC	20

Keyboard Exploded View (PX-7C)

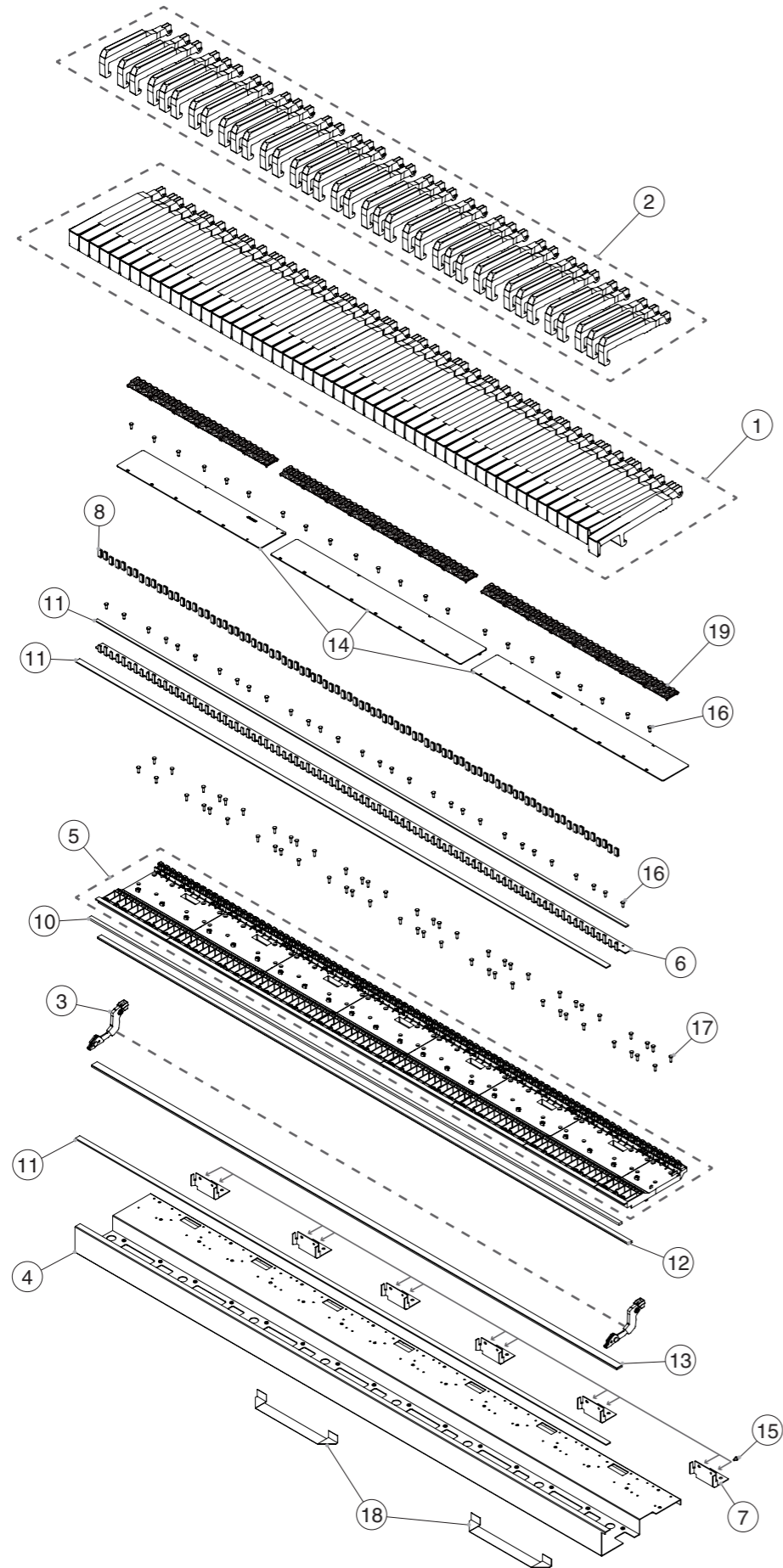

Keyboard Parts List (PX-7C)

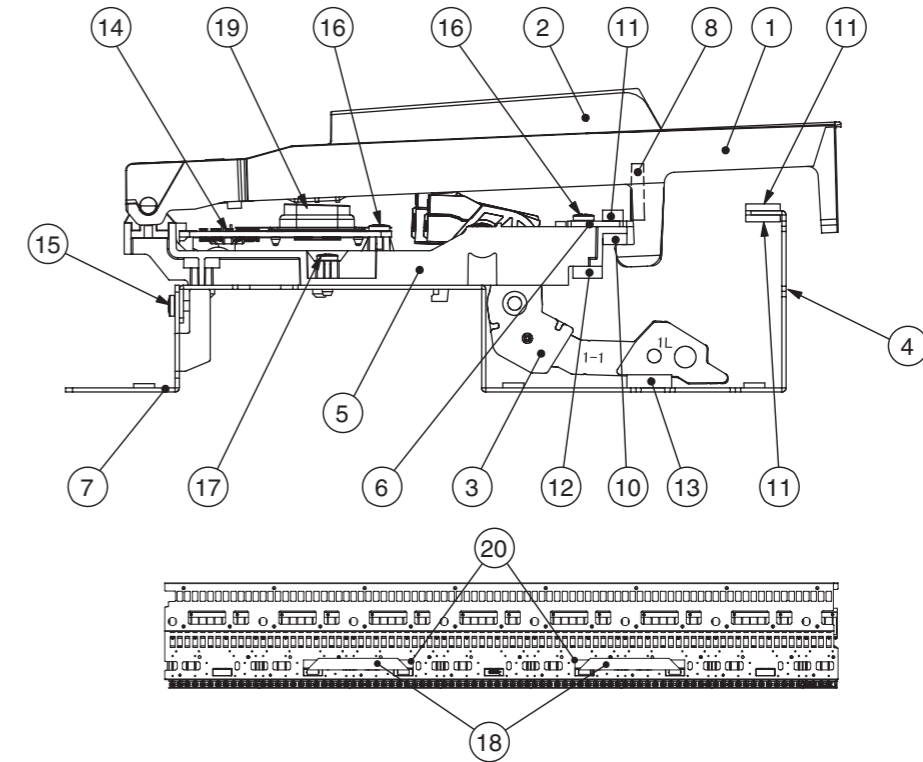

No.	Part Code	Part Name	Description	Q'ty
	5100054674	KEYBOARD ASSY	PX-7C SV SERVICE ASSY	
1	5100046363	N-KEY C	PX-7C	7
	5100046364	N-KEY D	PX-7C	7
	5100046365	N-KEY E	PX-7C	7
	5100046366	N-KEY F	PX-7C	7
	5100046367	N-KEY G	PX-7C	7
	5100046361	N-KEY A	PX-7C	7
	5100046362	N-KEY B	PX-7C	8
	5100046368	N-KEY A DASH	PX-7C	1
	5100046369	N-KEY C DASH	PX-7C	1
2	5100055829	S-KEY EBONY	PX-7C	36
3	5100048710	HAMMER-1 FOR N-KEY	PX-7C	13
	5100048711	HAMMER-2 FOR N-KEY	PX-7C	13
	5100048712	HAMMER-3 FOR N-KEY	PX-7C	13
	5100048713	HAMMER-4 FOR N-KEY	PX-7C	13
	5100048714	HAMMER-1 FOR S-KEY	PX-7C	9
	5100048715	HAMMER-2 FOR S-KEY	PX-7C	9
	5100048716	HAMMER-3 FOR S-KEY	PX-7C	9
	5100048717	HAMMER-4 FOR S-KEY	PX-7C	9
4	*****	CHASSIS 88P	PX-7	1
5	*****	SUB CHASSIS 12P	PX-7	7
	*****	SUB CHASSIS 4P	PX-7	1
6	*****	GUIDE HOLDER	PX-7	1
7	5100046729	KEYBOARD HOLDER	PX-7C	6
8	5100046717	GUIDE BUSHING	PX-7C	88
	5100019663	KEY CUSHION B	PX-7	1
11	5100048727	KEY STOP CUSHION B	PX-7	3
12	5100019111	HAMMER CUSHION A	PX-7	1
13	5100019664	HAMMER CUSHION B	PX-7	1
14	5100068954	PWB ASSY SET (GUH)	PX-7C/D	1
15	40011056	SCREW 3X6	BINDING TAPTITE B ZC	12
16	40011312	SCREW 3X8	BINDING TAPTITE P FE BZC	52
17	40012256	SCREW 3X10	BINDING TAPTITE B FE ZC	60
18	5100068059	FLAT CABLE	SML2CD-20X222-BDX8(BL)-P1.0-S4	2
19	5100047674	RUBBER SWITCH	12P	8
20	5100034564	DOUBLE-FACED TAPE	NITTO TAPE #501L W15MM 50M	-

* The cable (#5100070002) isn't included in this unit (#5100054674).

* For disassembly and maintenance of keyboard, refer to the Service Notes for PX-7B/C/D.

Parts List

Due to one or more of the following reasons, parts with parts code ***** cannot be supplied as service parts.

- Supply is prohibited due to copyright restrictions.
- It is carried in electronic data on the Roland web site.
- The part is made to order (at current market price).
- It is a package or an accessory irrelevant to the function maintenance of the main body.
- It is sold as a product.
- Reissuance is restricted.
- It is supplied as an assembled part (under a different part code).
- It can be replaced with an article on the market. (battery or etc.)
- A number of circuit boards are grouped together and supplied as a single circuit board (under a different part code).

Note: The parts marked # are new. (initial parts) The description "Q'ty" means a necessary number of the parts per one product.

CASING			
#	5100068961	TOP CASE	for BK 1
	5100047920	BOTTOM CASE	for BK 1
#	5100068962	TOP CASE	for WH 1
#	5100070076	BOTTOM CASE	for WH 1

CHASSIS			
	5100047911	CENTER HOLDER	4
	5100047922	SCREW HOLDER	4

KNOB, BUTTON			
	5100047913	KEYTOP	MX2H CLR 3
	5100047917	KEYTOP	MX4H CLR 2

SWITCH			
	01458501	TACT SWITCH	SKQMATE010 13

JACK, EXT TERMINAL			
	04452945	3.5MM JACK	YKB21-5344N 1
#	5100071299	6.5MM JACK	YKB21-5006W 1
	13449275	6.5MM JACK	YKB21-5074 3
#	5100068814	DC JACK	DC-021H-1-G 1
	00340223	DIN SOCKET	YKF51-5031 1
	04459190	USB CONNECTOR A TYPE FEMALE	YKF45-0033N 1
	5100009531	USB CONNECTOR B TYPE FEMALE	YKF45-0044N 1

SPEAKER, BUZZER			
	5100047143	SPEAKER	F1204-E34C 2

KEYBOARD ASSY			
	5100054674	KEYBOARD ASSY	PX-7C SV SERVICE ASSY 1

PWB ASSY			
#	5100068208	MAIN BOARD ASSY	1
#	5100068213	OUTPUT BOARD ASSY	1
	5100047904	JACK SHEET ASSY	(PHONES BD + PEDAL BD) 1
	* This unit includes the following parts.		
	*****	PHONES BOARD	1
	*****	PEDAL BOARD	1

WIRING, CABLE			
#	5100070002	WIRING	W1 (MAIN-KEY) 1
#	5100070003	WIRING	W2 (MAIN-PH) 1
#	5100070004	WIRING	W3 (MAIN-SP) 1
#	5100072104	WIRING	W4 (MAIN-KEYFRAME) 1
#	5100069935	WIRING	1061#28 3X150-PHR-PHR-F 1
	5100048744	WIRING	1061#28 7X150-PHR-PHR-F 1

SCREWS			
	40459534	SCREW M3X10	PAN MACHINE W/SW+PW(5.8MM) BZC 6
	40011056	SCREW 3X6	BINDING TAPTITE B ZC 2
	40011312	SCREW 3X8	BINDING TAPTITE P FE BZC 11
	40011289	SCREW 3X10	BINDING TAPTITE P FE ZC 2
	40012301	SCREW 4X8	BINDING TAPTITE B FE ZC 31
	40012490	SCREW 4X10	BINDING TAPTITE P BZC 34
	5100047746	SCREW 4X14	BINDING TAPTITE P BZC 8
	5100059056	RESIN WASHER	3.2X8X1.5 2

MISCELLANEOUS				
	5100047918	LED INDICATOR		1
	5100027106	CORD HOOK	40516-014	1
	5100049094	FOOT	SJ-5012 BLK	5
	5100061992	ABSORPTIVE FELT	245X25	1
	5100049479	ABSORPTIVE FELT A		1
	5100049480	ABSORPTIVE FELT B		1
	5100049481	ABSORPTIVE FELT C		1
	5100049568	ABSORPTIVE FELT D		1
	5100052508	KEY FELT		1
	5100049095	CUSHION A		2
	5100049096	CUSHION B		2
	5100049097	CUSHION C		2
	5100048657	KEYTOP CUSHION		1
	5100048658	TACT SW CUSHION		1
	40017378	COATING CLIP	CS-7	6
	40016545	LOCKING TOOL FOR INSULOK TIE	SKM-1	1
	40016523	INSULOK TIE 100M/M T-18R	(1000 PCS ORDERING PER)	7
	40122789	ACETATE TAPE	NITTO #156A W15MM 30M	-
	40232123	ACETATE TAPE	NITTO #5 BLACK W20MM 30M	-
	5100021076	DOUBLE SIDED ADHESIVE TAPE	NITTO #5000NS W5MM	-
	40567623	DOUBLE-FACED TAPE	#575 W15MM 30M	-
	17041858	GREASE FOR KEY	MOLYKOTE G-1039 (50 GRAM)	-
	17049543	GREASE FOR KEY	FLOIL G-336A WHITE (93 GRAM)	-

ACCESSORIES (Standard)				
#	5100069603	MUSIC REST	BK	for BK 1
#	5100069610	MUSIC REST	WH	for WH 1
#	5100069327	OWNER'S MANUAL	MULTILANGUAGE	1
#	5100069328	OWNER'S MANUAL	MULTILANGUAGE & CHINESE	1
	5100047496	AC ADAPTOR	PSB-7U(S)2 WITHOUT AC CORD	1
	5100048283	AC CORD SET	100V EYEGLASS ARK-VFF 1.0M	(19) for 100V 1
	5100012293	AC CORD SET	117VBL 1.0M FOR PSB	(26) for 117VBL 1
	02562456	AC CORD SET	120V 1.0M (NON POLAR)	(22), (28) for 117VU, 117VU/CS 1
	5100019558	AC CORD SET	220V CCC SP505A-IS037 1.0M	(66) for 220VCN 1
	5100039367	AC CORD	SP021A+IS037 220VK 2.5M 2P	(65) for 220VK 1
	01903356	AC CORD SET	230V 1.0M FOR PSB	(38) for 230V 1
	5100018086	AC CORD SET	230VE 1.0M FOR EPS	(38) for 230VE 1
	5100033404	AC CORD SET	240V SP501-IS037 PSB 1.0M	(59) for 240VA 1

Block/Wiring Diagram

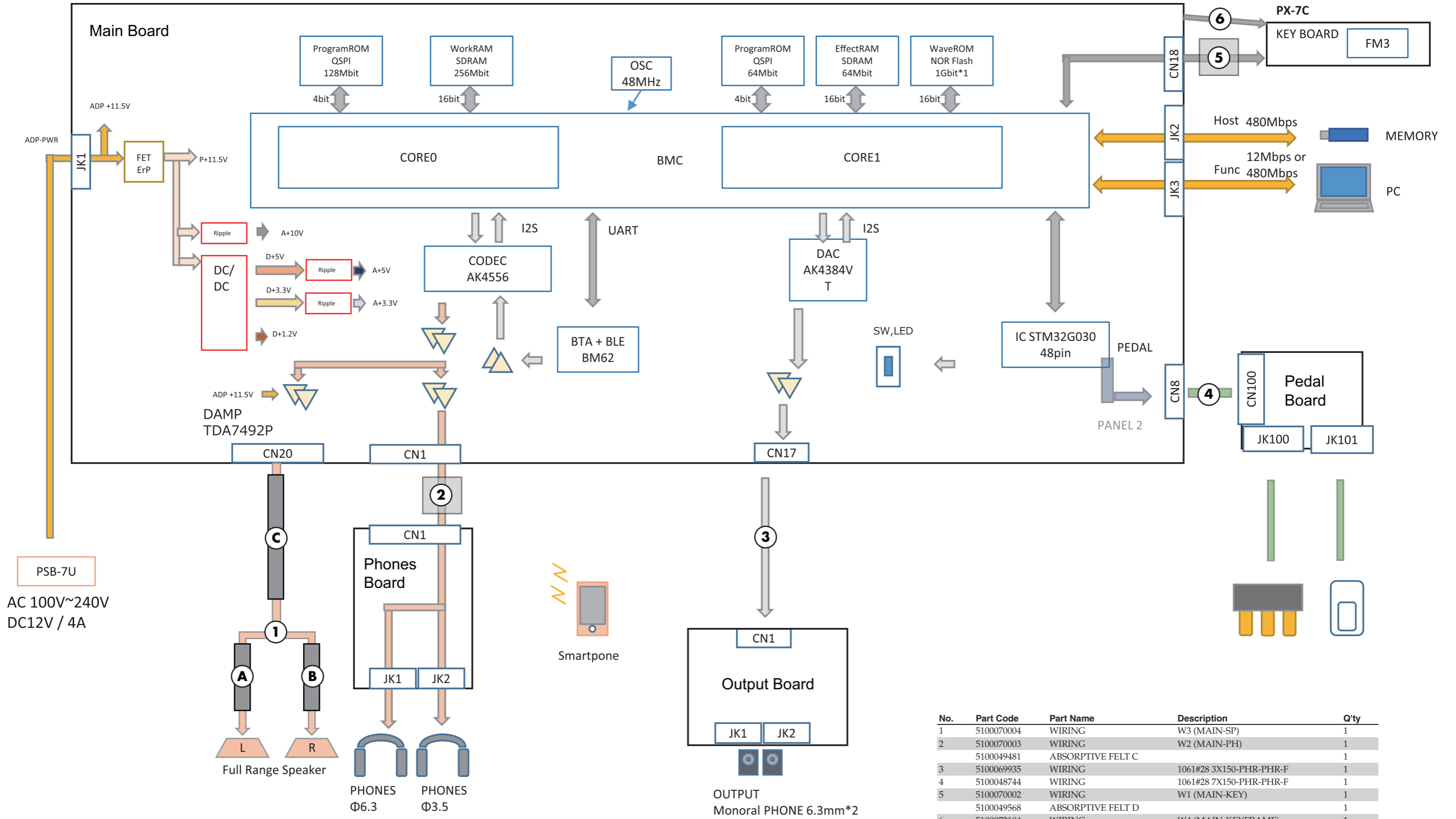

No.	Part Code	Part Name	Description	Q'ty
1	5100070004	WIRING	W3 (MAIN-SP)	1
2	5100070003	WIRING	W2 (MAIN-PH)	1
	5100049481	ABSORPTIVE FELT C		1
3	5100069935	WIRING	1061#28 3X150-PHR-PHR-F	1
4	5100048744	WIRING	1061#28 7X150-PHR-PHR-F	1
5	5100070002	WIRING	W1 (MAIN-KEY)	1
	5100049568	ABSORPTIVE FELT D		1
6	5100072104	WIRING	W4 (MAIN-KEYFRAME)	1
A	5100049479	ABSORPTIVE FELT A		1
B	5100049480	ABSORPTIVE FELT B		1
C	5100061992	ABSORPTIVE FELT	245X25	1

Circuit Board (Pedal, Phones Board)

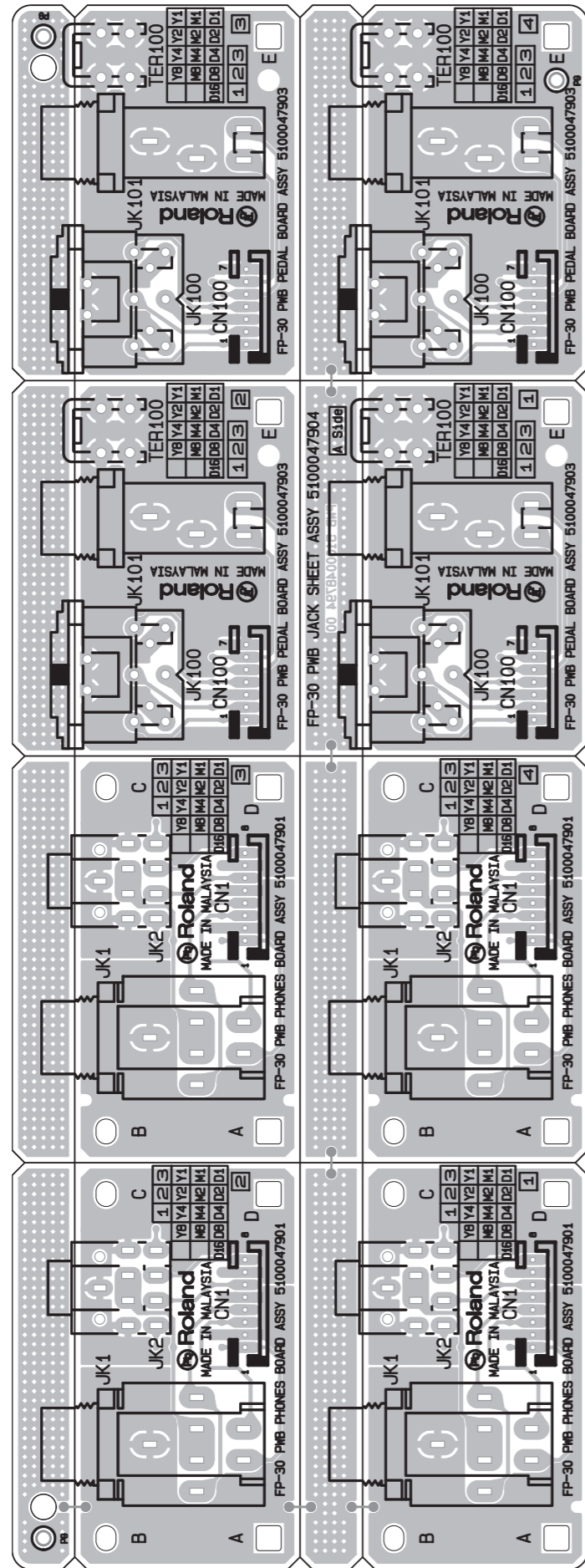

Circuit Diagram (Pedal Board)

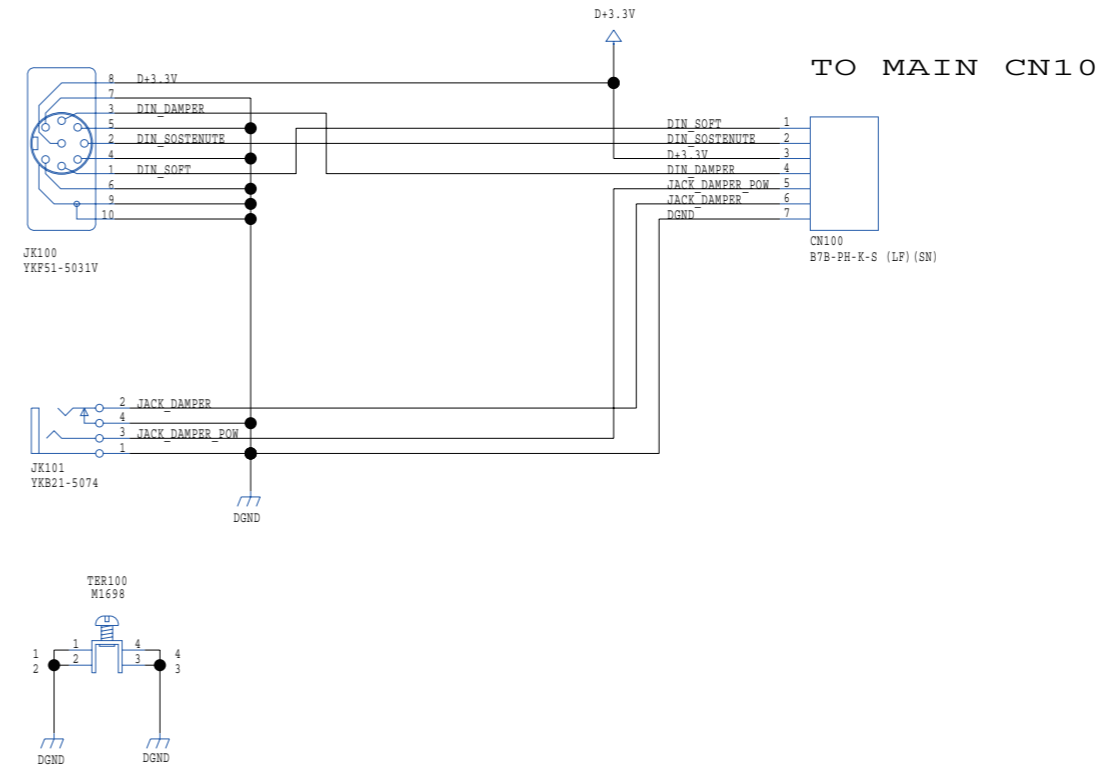

Circuit Diagram (Phones Board)

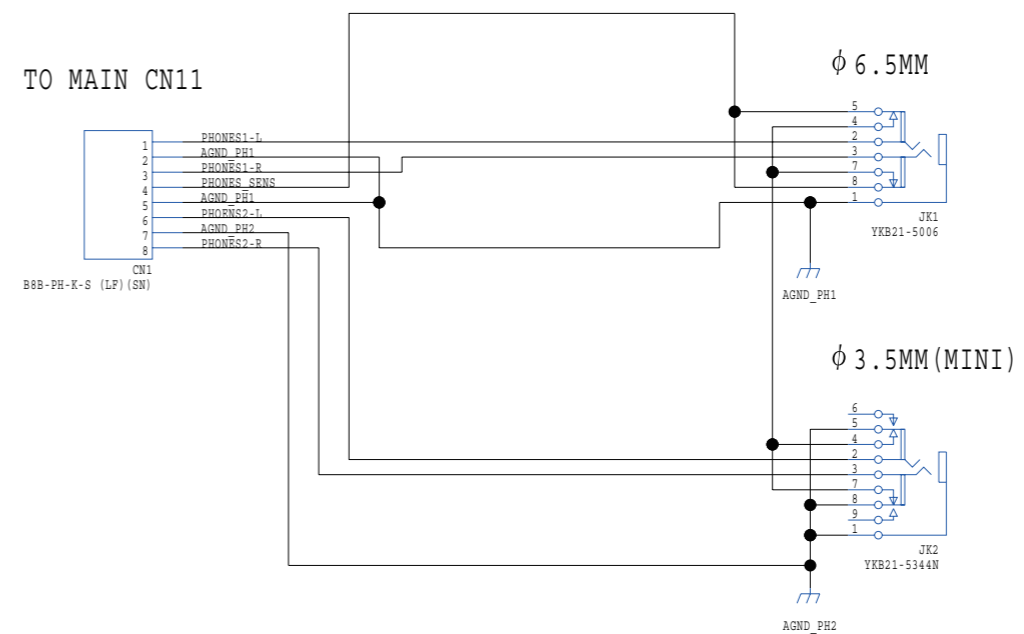

Circuit Board (Output Board)

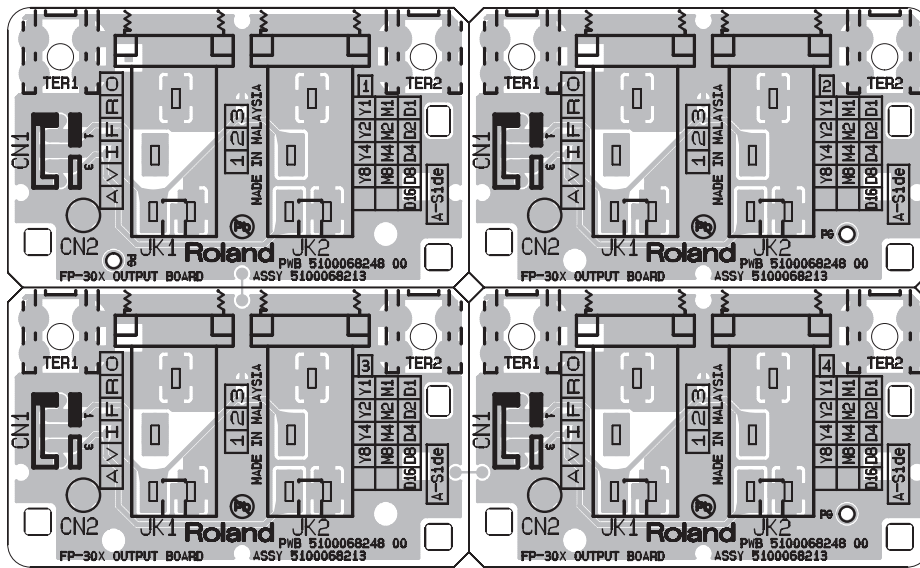

Circuit Diagram (Output Board)

To MAIN CN17

