

Digital Delay

SERVICE NOTES

Issued by RJA

DD-3(T)

DD-3C

Table of Contents

Distinguishing the DD-3, 3A, 3B, and 3C	2	Verifying the Version.....	11
Cautionary Notes	2	Data Backup and Restore Operations	11
Specifications	3	Performing a Factory Reset.....	11
Location of Controls	4	Updating the System	11
Location of Controls Parts List.....	4	Operation Test	11
Exploded View	5	Circuit Board (Main, VR, LED, Input, Output, SW Board).....	14
Exploded View Parts List.....	5	Circuit Diagram (Main, VR, LED, Input, Output, SW Board).....	16
Modification to the DD-3C	6		
Important Notes on Assembly	7		
Parts List.....	9		

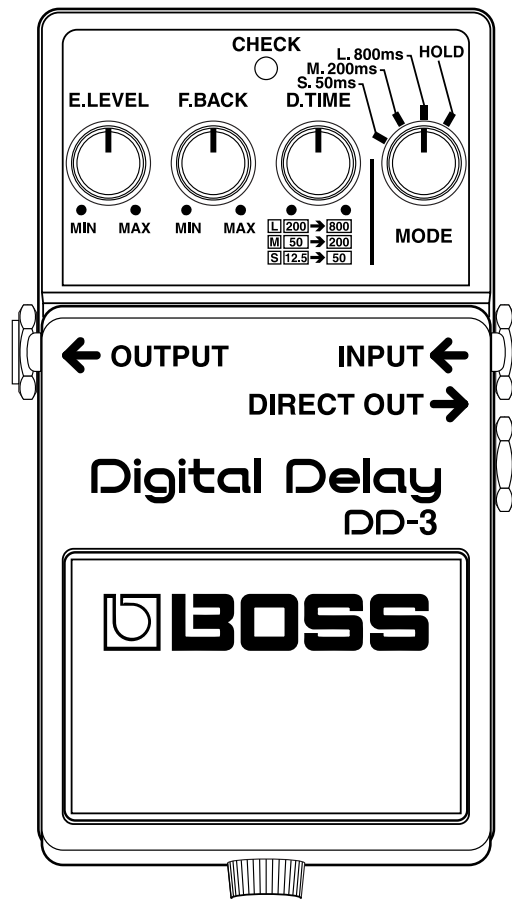

Copyright © 2010 Roland Corporation

All rights reserved. No part of this publication may be reproduced in any form without the written permission of Roland Corporation.

Distinguishing the DD-3, 3A, 3B, and 3C

The DD-3 and DD-3(T) include four types having differing circuit structures: the **DD-3**, **DD-3A**, **DD-3B**, and **DD-3C**. On each, the pedal is labeled **Digital Delay DD-3**, making them appear identical at first glance, but you can use the following two methods to tell them apart.

After distinguishing the type of the product to be serviced, refer to the corresponding Service Notes for the required parts and test methods.

DD-3:	Service Notes DD-2/3 (#17059183)
DD-3A:	Service Notes DD-3A (#17059557)
DD-3B:	Service Notes 3rd Edition (#17059557E3)
DD-3C:	Service Notes DD-3C (#17059557E4)

This version of Service Notes is for the DD-3C.

Distinguishing the Product (1)

The four types can be distinguished by differences in appearance, production number, and components mounted on the circuit board. Refer to the table below.

	DD-3		DD-3(T)	
	DD-3A	DD-3B	DD-3C	
Appearance	Figure 1		Figure 2	
Production number	Up to SO81199		S91200 or later	
Components on circuit board	Radial components present		Radial components absent	

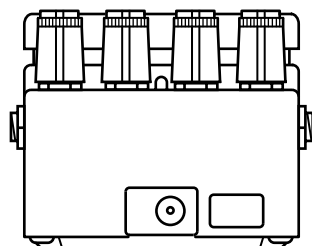

Figure 1 — DD-3

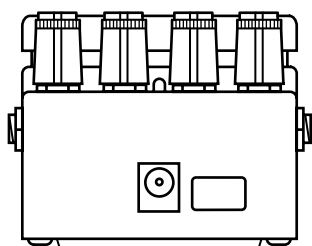

Figure 2 — DD-3A, DD-3B, or DD-3C

Distinguishing the Product (2)

The DD-3C can be distinguished from the DD-3A or DD-3B by differences in operation when an AC adaptor is connected.

* This method is limited to correctly operating products.

Follow the procedure shown below.

1. Connect an AC adaptor.
2. Adjust the **MODE** control to a setting other than **HOLD**.
3. Depress the pedal.
If the **CHECK** indicator lights up at this time, the product is the DD-3A or DD-3B. The DD-3C does not light up.
4. Insert a plug into the **INPUT** jack.
If the **CHECK** indicator lights up for the first time here, the product is the DD-3C.

Cautionary Notes

Before beginning the procedure, please read through this document. The matters described may differ according to the model.

No User Data

This product cannot save user data. Backing up user data during servicing is not required.

Part Replacement

When replacing components near the power-supply circuit or a heat-generating circuit (such as a circuit provided with a heat sink or including a cement resistor), carry out the procedure according to the instructions with respect to the part number, direction, and attachment position (mounting so as to leave an air gap between the component and the circuit board, etc.).

Parts List

A component whose part code is ***** will not be supplied as a service part because one of the following reasons applies.

- Because it is supplied as an assembled part (under a different part code).
- Because a number of circuit boards are grouped together and supplied as a single circuit board (under a different part code).
- Because supply is prohibited due to copyright restrictions.
- Because reissuance is restricted.
- Because the part is made to order (at current market price).
- Because it is carried in electronic data on the Roland web site.
- Because it is a package or an accessory irrelevant to the function maintenance of the main body.
- Because it can be replaced with an article on the market. (battery or etc.)

Circuit Diagram

In the circuit diagram, "NIU" is an abbreviation for "Not in Use," and "UnPop" is an abbreviation for "Unpopulated." They both mean non-mounted components. The circuit board and circuit board diagram show silk-screened indications, but no components are mounted.

Specifications

DD-3: Digital Delay (DD-3C)

Power Supply

DC 9 V; Dry battery 6LR61 (9 V) type (alkaline),
AC Adaptor (PSA series: Option)

Current Draw

35 mA (DC 9 V)

* *Expected battery life under continuous use:*

- Carbon: 2 hours
- Alkaline: 8 hours

These figures will vary depending on the actual conditions of use.

Controls

EFFECT LEVEL, FEEDBACK, DELAY TIME,

Others

MODE SELECTOR Switch

Pedal Switch

Indicator

Check Indicator (serves also as battery check indicator)

Jacks

INPUT, DIRECT OUTPUT, MAIN OUTPUT, AC Adaptor

Delay Time

12.5 ms (MIN) to 800 ms (MAX)

S (Short) 50 ms (12.5 ms to 50 ms)

M (Middle) 200 ms (50 ms to 200 ms)

L (Long) 800 ms (200 ms to 800 ms)

Hold Time

200 ms (MIN) to 800 ms (MAX) in Hold mode

Frequency Response

Delay Sound: 40 Hz to 7 kHz; +1/-3 dB

Direct Sound: 10 Hz to 60 kHz; +1/-3 dB

Residual Noise

-95 dBu (IHF-A, Typ.)

Input Impedance

1 M Ω

Output Load Impedance

10 k Ω or greater

Dimensions

73 (W) x 129 (D) x 59 (H) mm

2-7/8 (W) x 5-1/8 (D) x 2-3/8 (H) inches

Weight

450 g / 1 lb (including battery)

Accessories

Owner's Manual (#5100015110)

Dry battery /9 V type (6LR61) (#*****)

Leaflet ("USING THE UNIT SAFELY," "IMPORTANT NOTES," and "Information") (#*****)

Options

AC Adaptor PSA series

* $0 \text{ dBu} = 0.775 \text{ Vrms}$

* *Printed matters will not be supplied after the end of the production. Then, download the electronic file from the Roland web site.*

* *In the interest of product improvement, the specifications and/or appearance of this unit are subject to change without prior notice.*

Location of Controls

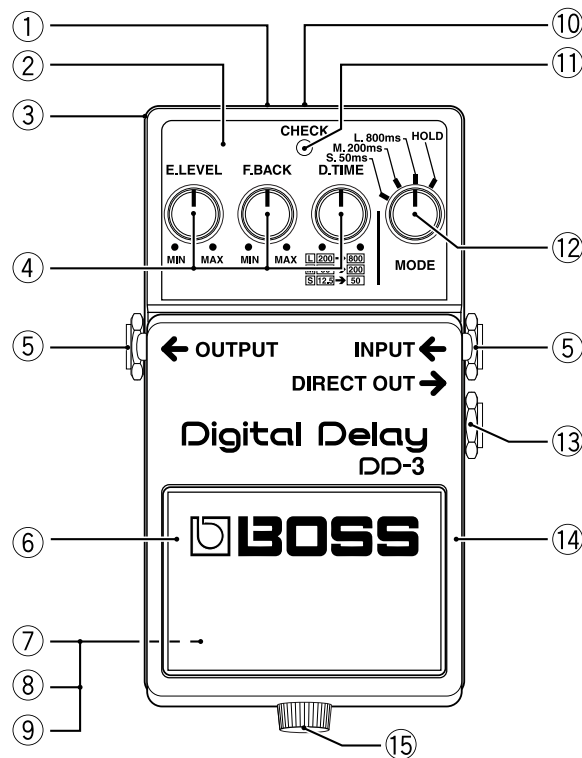

Location of Controls Parts List

No.	Part Code	Part Name	Description	Q'ty
1	5100014487	COMPACT PSA LABEL	(22537538R0)	1
2	22217404R0	PANEL		1
3	75D563C0R0	CASE (PEARL WHITE)		1
4	5100008175	R-KNOB	F BLU / BLK (G2477530R0)	3
	F3279852R0	POTENTIOMETER	RD901-20-15FW-B54-006	3
5	01903234	6.5MM JACK	HTJ-064-13D	2
	5100003926	PLAIN WASHER 9X13.5X0.5T	NI(H5039158R0)	2
	5100008086	INT TOOTH WASHER 9.5X12.5X0.5	NI RTC(H5039205R0)	2
	5100003918	JACK NUT M9X12X2	NI RTC(H5039510R0)	2
6	5100008294	PEDAL PLATE	(22357304R0)	1
7	5100006632	BOTTOM COVER	(22027851R0)	1
8	5100006633	BOTTOM FOOT	(22357305R0)	1
9	5100006631	CAUTION SEAL	PSA (FCC / EMI)(G2537516R2)	1
10	04908712	DC JACK	KM02020ABM2P (F3439892R0)	1
11	15029281	LED (RED)	GL-3PR8	1
12	5100008175	R-KNOB	F BLU / BLK (G2477530R0)	1
	5100014193	R.POTENTIOMETER (F3279853R0)	RD901F-20-15FB-B50K-04	1
13	5100006457	6.5MM JACK	HTJ-064-14D(13449140R0)	1
	5100003926	PLAIN WASHER 9X13.5X0.5T	NI(H5039158R0)	1
	5100008086	INT TOOTH WASHER 9.5X12.5X0.5	NI RTC(H5039205R0)	1
	5100003918	JACK NUT M9X12X2	NI RTC(H5039510R0)	1
14	75D562T0R0	PEDAL		1
15	5100007512	THUMB SCREW	(H5029820R0)	1

Exploded View

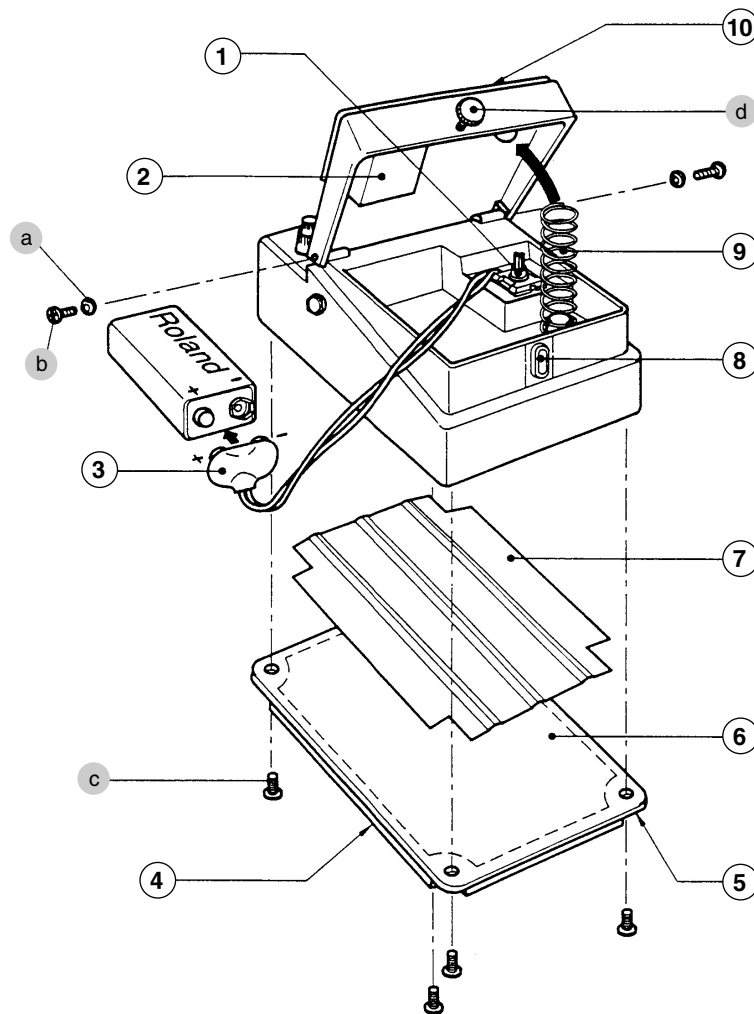

Exploded View Parts List

No.	Part Code	Part Name	Description	Q'ty
1	13129710R0	SWITCH(PUSH)	JM-0404	1
2	5100007503	BATTERY CUSHION	(22267333R0)	1
3	5100007872	BATTERY CONNECTOR	006P BATTERY SNAP (F3419102R0)	1
4	5100006631	CAUTION SEAL	PSA (FCC/EMI)(G2537516R2)	1
5	5100006633	BOTTOM FOOT	(22357305R0)	1
6	5100006632	BOTTOM COVER	(22027851R0)	1
7	5100007509	INSULATING SHEET	(75D273W0R0)	1
8	5100007505	PEDAL GUIDE BUSH	(22157702R0)	1
9	5100007504	COIL SPRING	(22177109R0)	1
10	5100008294	PEDAL PLATE	(22357304R0)	1
a	5100008092	PLAIN WASHER 3X6X0.5	RESIN RTC(H5039708R0)	2
b	40010267	SCREW M3X10	BINDING MACHINE FE BZC	2
c	5100007965	SCREW 3X6(H5029325R0)	PAN TAPPING B1 BZC	4
d	5100007512	THUMB SCREW	(H5029820R0)	1

Modification to the DD-3C

When modifying a DD-3, DD-3A, or DD-3B to transform it into a DD-3C, replace the respective parts shown in the table below.
 For the circuit boards in particular, all circuit board must be replaced at the same time.

DD-3			DD-3C			
Part Code	Part Name	Description		Part Code	Part Name	Description
75224510	EFFECT BOARD ASSY	ET-1	->	5100013258	MAIN SHEET ASSY	DD-3C
*****	EFFECT BOARD			*****	MAIN BOARD	
*****	VOLUME BOARD			*****	VR BOARD	
*****	LED BOARD			*****	LED BOARD	
*****	SW BOARD			*****	SW BOARD	
*****	DC SUPPLY BOARD			*****	INPUT BOARD	
				*****	OUTPUT BOARD	
2216752901	INSULATION SHEET		->	5100007509	INSULATING SHEET	(75D273W0R0)
2201017200	CASE	201-172	->	75D563C0R0	CASE (PEARL WHITE)	
2235030500	BOTTOM BASE	235-305	->	5100006633	BOTTOM FOOT	(22357305R0)
2202011600	BOTTOM COVER	202-116	->	5100006632	BOTTOM COVER	(22027851R0)
2247026200	KNOB	247-262 (BLUE)	->	5100008175	R-KNOB	F BLU/BLK (G2477530R0)
-	-	-	->	5100014487	COMPACT PSA LABEL	(22537538R0)
-	-	-	->	5100006631	CAUTION SEAL	PSA (FCC/EMI)(G2537516R2)
2603768604	OWNER'S MANUAL	JAPANESE	->	5100015109	OWNER'S MANUAL	JAPANESE
2603768704	OWNER'S MANUAL	ENGLISH	->	5100015110	OWNER'S MANUAL	ENGLISH

DD-3A			DD-3C			
Part Code	Part Name	Description		Part Code	Part Name	Description
7527351000	MT BOARD ASSY	(INC. VR/LED BOARD)	->	5100013258	MAIN SHEET ASSY	DD-3C
*****	MT BOARD			*****	MAIN BOARD	
*****	VR BOARD			*****	VR BOARD	
*****	LED BOARD			*****	LED BOARD	
				*****	SW BOARD	
				*****	INPUT BOARD	
				*****	OUTPUT BOARD	
2216059400	INSULATION SPACER	216-594	->	5100007509	INSULATING SHEET	(75D273W0R0)
2247026200	KNOB	247-262 (BLUE)	->	5100008175	R-KNOB	F BLU/BLK (G2477530R0)
2253753801	PSA CAUTION	253-538	->	5100014487	COMPACT PSA LABEL	(22537538R0)
2253053900	BOTTOM CAUTION	253-539	->	5100006631	CAUTION SEAL	PSA (FCC/EMI)(G2537516R2)
2603768604	OWNER'S MANUAL	JAPANESE	->	5100015109	OWNER'S MANUAL	JAPANESE
2603768704	OWNER'S MANUAL	ENGLISH	->	5100015110	OWNER'S MANUAL	ENGLISH

DD-3B			DD-3C			
Part Code	Part Name	Description		Part Code	Part Name	Description
75D563P0R0	MT BOARD ASSY	DD-3B(75D573P0R0)	->	5100013258	MAIN SHEET ASSY	DD-3C
*****	MAIN BOARD			*****	MAIN BOARD	
*****	VR BOARD			*****	VR BOARD	
*****	LED BOARD			*****	LED BOARD	
*****	SW BOARD			*****	SW BOARD	
				*****	INPUT BOARD	
				*****	OUTPUT BOARD	
2247026200	KNOB	247-262 (BLUE)	->	5100008175	R-KNOB	F BLU/BLK (G2477530R0)
2253753801	PSA CAUTION	253-538	->	5100014487	COMPACT PSA LABEL	(22537538R0)
G253751603	BOTTOM CAUTION PSA	FCC/CE/C-TICK/EMC GRY	->	5100006631	CAUTION SEAL	PSA (FCC/EMI)(G2537516R2)
2603768604	OWNER'S MANUAL	JAPANESE	->	5100015109	OWNER'S MANUAL	JAPANESE
2603768704	OWNER'S MANUAL	ENGLISH	->	5100015110	OWNER'S MANUAL	ENGLISH

When assembling, refer to **Important Notes on Assembly** (p. 7).

* For information on the modification method to create a DD-3B, refer to Service Information No. 100852.

Important Notes on Assembly

Installing the Output Jack

* Ensure that the wiring is not pinched.

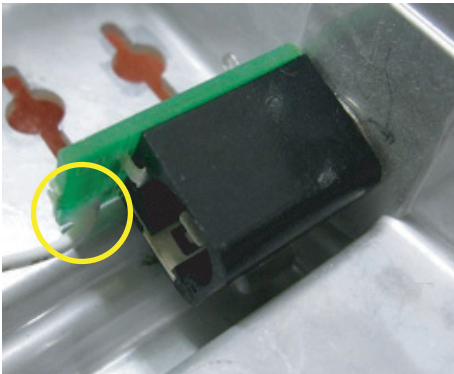

* Be sure not to let the Output jack touch the case.

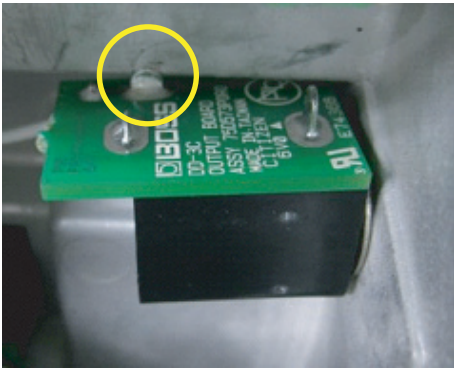

Installing the Input Jack

* When installing, be sure to hold down the Input Board with your hand and keep the jack from tilting at an angle.

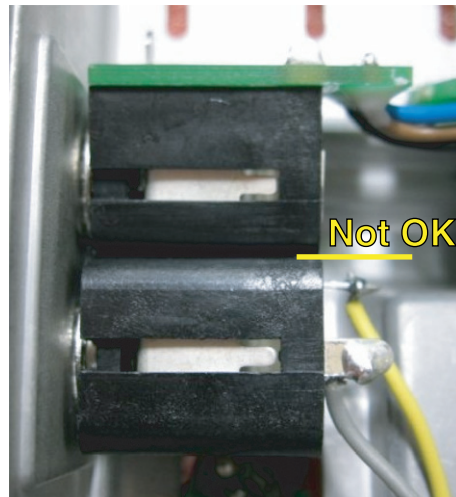
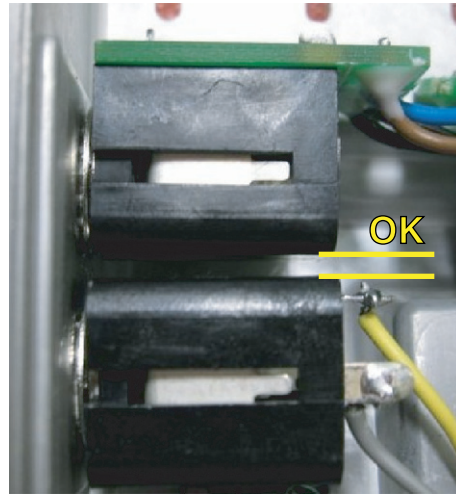

Installing the Direct Out Jack

Solder the wiring from the Direct Out jack to **TP69** and **TP81** on the Main Board.

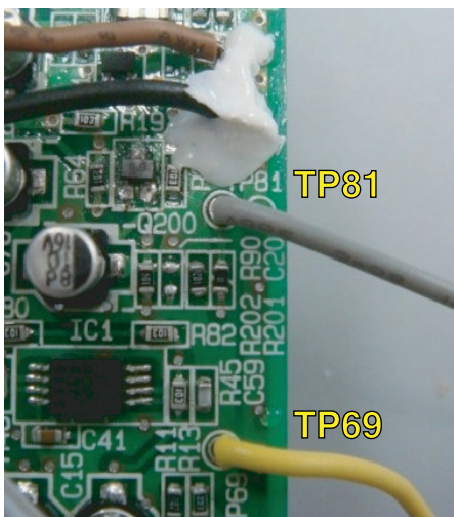

Disposition of Wiring

1. Insert the green and orange wires behind the ribbon cable (between the VR Board and the Case).

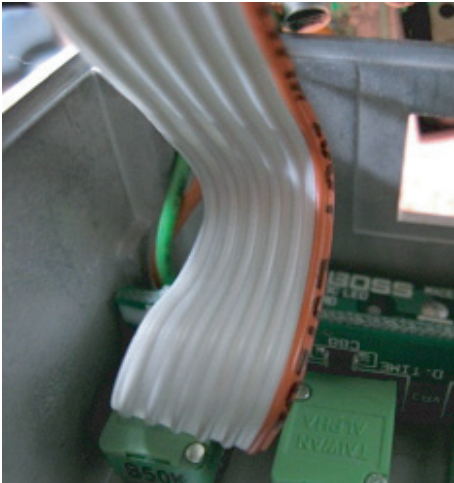

2. Arrange the wiring as shown in the figure.

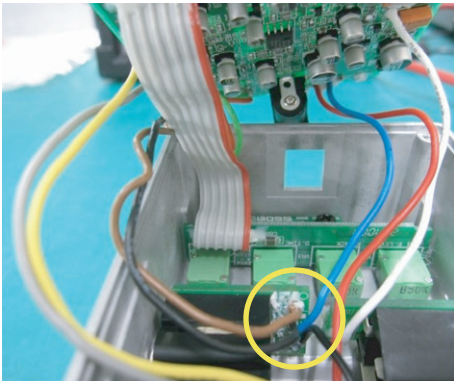

* Ensure that the Input-Board wires (brown and black) do not become tangled. Arrangement as shown in the figure above is OK.

3. Twist the Input-Board wires (brown and black).

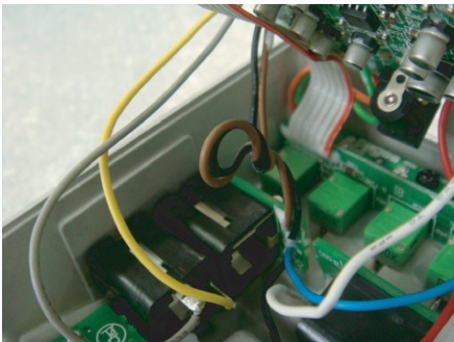

4. Insert the Input-Board wires (brown and black) between the potentiometer and the Input Board.

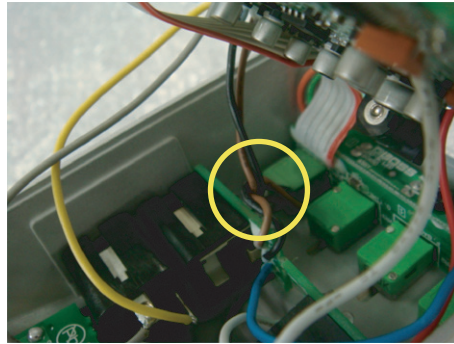

5. Twist any excess length of the wires as shown in the figure.

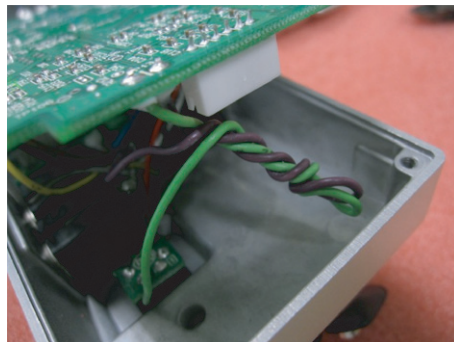

* Noise may occur if the Input-Board wires (brown and black) are too close to the area around IC6.

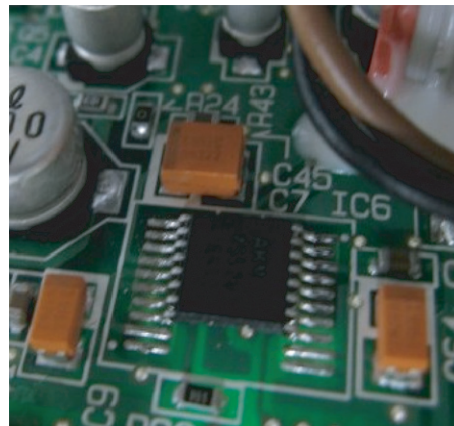

Parts List

Safety Precautions:
The parts marked Δ have safety-related characteristics. Use only listed parts for replacement.

Due to one or more of the following reasons, parts with parts code ***** cannot be supplied as service parts.

- Part supplied only as a component in a complete assembly
- Copyright does not permit the part to be supplied
- Part is sold commercially

Note: The parts marked # are new. (initial parts) The description "Q'ty" means a necessary number of the parts per one product.

CASING				
	75D563C0R0	CASE (PEARL WHITE)		1
	22217404R0	PANEL		1
	75D562T0R0	PEDAL		1
	5100006632	BOTTOM COVER	(22027851R0)	1
CHASSIS				
	5100008294	PEDAL PLATE	(22357304R0)	1
KNOB, BUTTON				
#	5100008175	R-KNOB	F BLU/BLK (G2477530R0)	4
SWITCH				
	13129710R0	SWITCH(PUSH)	JM-0404	1
JACK, EXT TERMINAL				
	04908712	DC JACK	KM02020ABM2P (F3439892R0)	1
	01903234	6.5MM JACK	HTJ-064-13D	2
	5100006457	6.5MM JACK	HTJ-064-14D(13449140R0)	1
			not included in Main Sheet Assy	
PWB ASSY				
#	5100013258	MAIN SHEET ASSY	DD-3C	1
		* This unit includes the following parts.		
	*****	MAIN BOARD		1
	*****	VR BOARD		1
	*****	LED BOARD		1
	*****	INPUT BOARD		1
	*****	OUTPUT BOARD		1
	*****	SW BOARD		1
DIODE				
	15029281	LED (RED)	GL-3PR8	1
#	5100001583	DIODE	SS14 (F5339137R0)	1
POTENTIOMETER				
	F3279852R0	POTENTIOMETER	RD901-20-15FW-B54-006	3
#	5100014193	R.POTENTIOMETER (F3279853R0)	RD901F-20-15FB-B50K-04	1
WIRING, CABLE				
#	5100008079	WIRING UL1007 OS-1 AWG24	PUR 160X6EX6E (H4009498R1)	1
#	5100008080	WIRING UL1007 OS-1 AWG24	GRN 160X6EX6E (H4009499R1)	1
#	5100010401	WIRING UL1007 OS-1 AWG24	WHT 100X6EX6E (H4009809R0)	1
#	5100014617	WIRING UL1007 OS-1 AWG24	ORG 80X6EX6E (H4019509R0)	1
#	5100014618	WIRING UL1007 OS-1 AWG24	GRN 80X6EX6E (H4019510R0)	1
#	5100014619	WIRING UL1007 OS-1 AWG24	BLU 100X6EX6E (H4019508R0)	1
#	5100014620	WIRING UL1007 OS-1 AWG24	BLK 115X6EX6E (F3487020R0)	1
#	5100014621	WIRING UL1007 OS-1 AWG24	YEL 110X3X6 (H4009526R0)	1
#	5100014622	WIRING UL1007 OS-1 AWG24	GRY 110X3X6 (H4009339R0)	1
#	5100014623	WIRING UL1007 OS-1 AWG24	BRN 115X6EX6E (H4019507R0)	1
#	5100014307	RIBBON CABLE	6X80MM (F3477063R0)	1
#	5100007872	BATTERY CONNECTOR	006P BATTERY SNAP (F3419102R0)	1
			not included in Main Sheet Assy	
			not included in Main Sheet Assy	

SCREWS

40010267	SCREW M3X10	BINDING MACHINE FE BZC	2
5100007965	SCREW 3X6(H5029325R0)	PAN TAPPING B1 BZC	5
5100007512	THUMB SCREW	(H5029820R0)	1
40128923	HEX NUT M7		4
5100003918	JACK NUT M9X12X2	NI RTC(H5039510R0)	3
5100008092	PLAIN WASHER 3X6X0.5	RESIN RTC(H5039708R0)	2
5100003926	PLAIN WASHER 9X13.5X0.5T	NI(H5039158R0)	3
5100008086	INT TOOTH WASHER 9.5X12.5X0.5	NI RTC(H5039205R0)	3

MISCELLANEOUS

	5100006633	BOTTOM FOOT	(22357305R0)	1
	5100007503	BATTERY CUSHION	(22267333R0)	1
	5100006631	CAUTION SEAL	PSA (FCC/EMI)(G2537516R2)	1
#	5100014487	COMPACT PSA LABEL	(22537538R0)	1
	5100007504	COIL SPRING	(22177109R0)	1
#	5100006330	EARTH TERMINAL	(22257257R0)	4
	5100007509	INSULATING SHEET	(75D273W0R0)	1
#	5100007870	INSULOK TIE	YJ-80 V2 (H5319102R0)	1
	5100007505	PEDAL GUIDE BUSH	(22157702R0)	1
	H2369402R0	POLYCA PIPE	#306 3X6X6	1

ACCESSORIES (Standard)

#	5100015109	OWNER'S MANUAL	JAPANESE	1
#	5100015110	OWNER'S MANUAL	ENGLISH	1

Verifying the Version

1. Turn all controls all the way counterclockwise.
2. Hold down the pedal and insert a 1/4-inch stereo phone plug into the **INPUT** jack.
The power comes on and the **CHECK** LED lights up.
After approximately 2 seconds, the **CHECK** LED flashes, and the number of flashes indicates the version.
Examples: 1 flash: Version 1.00
2 flashes: Version 1.01
3 flashes: Version 1.02
3. Release the pedal.
After the version display, the unit automatically changes to the Test Mode.

Data Backup and Restore Operations

This product cannot save user data. Backing up user data during servicing is not required.

Performing a Factory Reset

This product has no factory-reset feature.

Updating the System

A system update cannot be performed for this product. If an update is required, replace with an updated circuit board. Updates can be accomplished only at the factory.

Operation Test

Items Required

- AC adaptor (PSA-series device)
- Amp-equipped monitor speaker x 1
- Signal generator x 1
- Oscilloscope x 1
- Noise meter x 1
- Stabilized power supply x 1
- Ammeter x 1
- 47-k Ω dummy plug (1/4-inch mono phone type) x 1

Inspection Items

1. **Measurement of Current Consumption** (p. 12)
2. **Volume and AD/DA Test** (p. 12)
3. **Noise Test** (p. 12)
4. **MODE Test** (p. 13)
5. **DIRECT OUT Test** (p. 13)
6. **BYPASS Test** (p. 13)
7. **LED and Battery Operation Test** (p. 13)

The tests just described can safely be carried out in any sequence. Also, some items involve testing while in the Test Mode, and others involve testing in the normal usage state. For detailed information, refer to the procedures for the respective test items described later in this document.

Entering the Test Mode and Verifying the Version

1. Turn all controls all the way counterclockwise.
2. Hold down the pedal and insert a 1/4-inch mono phone plug into the **INPUT** jack.
The power comes on and the **CHECK** LED lights up.
After approximately 2 seconds, the **CHECK** LED flashes, and the number of flashes indicates the version.
Examples: 1 flash: Version 1.00
2 flashes: Version 1.01
3 flashes: Version 1.02
3. Release the pedal.
After the version display, the unit automatically changes to the Test Mode.

Quitting the Test Mode

After entering the Test Mode and displaying the version, depress the pedal. Alternatively, disconnect the plug from the **INPUT** jack to switch off the power.

1. Measurement of Current Consumption

1. Make the connections as shown in the figure, then start the unit in the **Test Mode**.
(Connect the **OUTPUT** and **INPUT** jacks using an audio cable.)

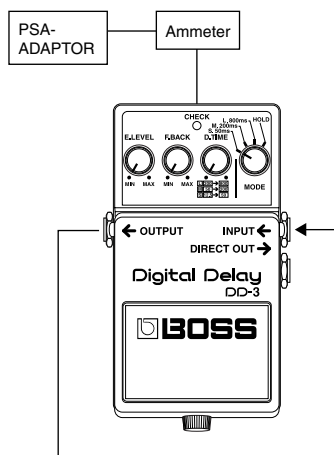

2. Verify that current consumption is **35 mA** or less.

2. Volume and AD/DA Test

1. Make the connections as shown in the figure, then start the unit in the **Test Mode**.
(Connect the **OUTPUT** and **INPUT** jacks using an audio cable.)

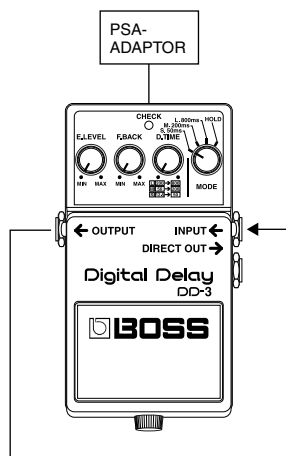

2. Turn the **E.LEVEL** control to near the nine o'clock position, and verify that the **CHECK** LED lights up.
3. Turn the **E.LEVEL** control to near the eleven o'clock position, and verify that the **CHECK** LED goes dark.
4. Turn the **E.LEVEL** control to near the one o'clock position, and verify that the **CHECK** LED lights up.
5. Turn the **E.LEVEL** control to **MAX** and verify that the **CHECK** LED goes dark.
6. Carry out steps 2 through 5 for the **F.BACK** and **D.TIME** controls as well. When the **D.TIME** control is turned to **MAX**, the AD/DA test is carried out automatically. The **CHECK** LED lights up steadily if the test results are OK, or flashes if the results are not OK.

3. Noise Test

1. Make the connections as shown in the figure, then start the unit in the **Test Mode**.

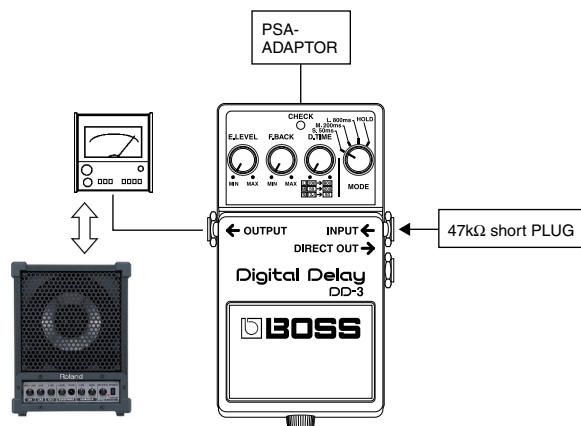

2. Connect the noise meter to the **OUTPUT** jack, and verify that residual noise is **-93 dBm** or less (DIN audio) or **-95 dBm** or less (JIS A).
3. Connect the amp-equipped monitor speaker to the **OUTPUT** jack.
4. Subject the unit to impact (by dropping it from a height of about 5 cm), and verify that no abnormal noise is heard from the speaker.
5. Depress the pedal several times, and verify that no switching noise occurs and that no wires are pinched between the switch and the pedal.
6. Depress the pedal to make the **CHECK** LED go dark. The effect is switched off.
7. Connect the noise meter to the **OUTPUT** jack, and verify that residual noise is **-100 dBm** or less (DIN audio) or **-102 dBm** or less (JIS A).
8. Disconnect the plug from the **OUTPUT** jack and connect the noise meter to the **DIRECT OUT** jack.

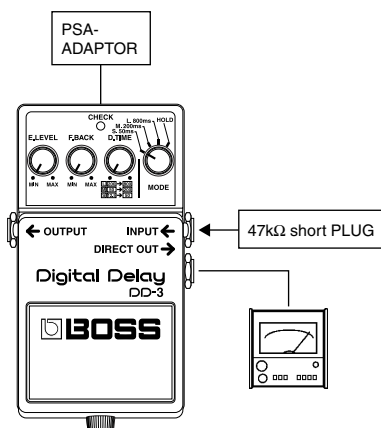

9. Verify that the **CHECK** LED is dark, then verify that residual noise is **-104 dBm** or less (DIN audio) or **-106 dBm** or less (JIS A).

4. MODE Test

1. Make the connections as shown in the figure below, then start the unit in the **normal usage state**.
(Set the **E.LEVEL** and **D.TIME** controls to **MAX** and center the **F.BACK** control.)

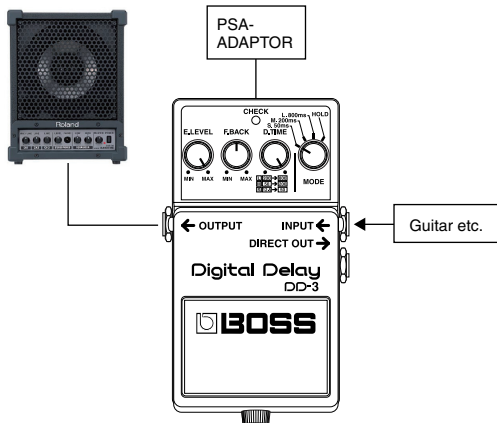

2. Turn the **MODE** control to **S. 50ms**, **M. 200ms**, and **L. 800ms**, and verify that the delay time changes.
3. Adjust the **MODE** control to **HOLD** and switch on the pedal, and verify that a sampling sound is produced.

5. DIRECT OUT Test

1. Make the connections as shown in the figure below, then start the unit in the **normal usage state**.

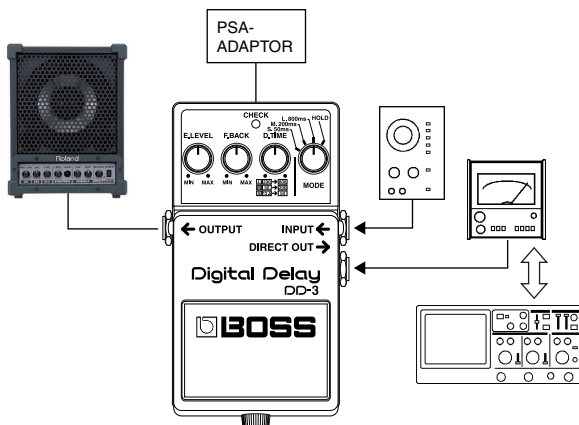

2. Adjust the **E.LEVEL**, **F.BACK**, and **D.TIME** controls to **MIN** and the **MODE** control to **S. 50ms**.
3. Depress the pedal to make the **CHECK** LED light up. The effect is switched on.
4. Input a suitable signal from the signal generator, and verify that sound is heard from the speaker.
5. Insert a plug into the **DIRECT OUT** jack, and verify that the audible sound stops.
6. Disconnect the plug from the **OUTPUT** jack.
7. Input signals like those shown below from the signal generator, and verify that the output signals are at the corresponding values.

* Set the filter on the noise meter to Flat or DIN audio.

Input signal	Output signal
80-Hz sine wave at 3.5 dBm	3 dBm±1.0 dBm
8,000-Hz sine wave at -21.5 dBm	-22 dBm±1.0 dBm

6. BYPASS Test

1. Make the connections as shown in the figure below, then start the unit in the **normal usage state**.

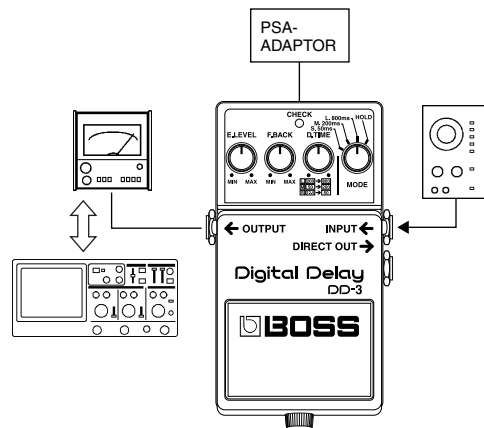

2. Depress the pedal to make the **CHECK** LED go dark. The effect is switched off.
 3. Input signals like those shown below from the signal generator, and verify that the output signals are at the corresponding values.
- * Set the filter on the noise meter to Flat or DIN audio.

Input signal	Output signal
80-Hz sine wave at 3.5 dBm	3 dBm±1.0 dBm
800-Hz sine wave at -1.5 dBm	-2 dBm±1.0 dBm
1,600-Hz sine wave at -11.5 dBm	-12 dBm±1.0 dBm
8,000-Hz sine wave at -21.5 dBm	-22 dBm±1.0 dBm

7. LED and Battery Operation Test

1. Insert a battery into the unit, make the connections as shown in the figure, then start the unit in the **usual usage state**.

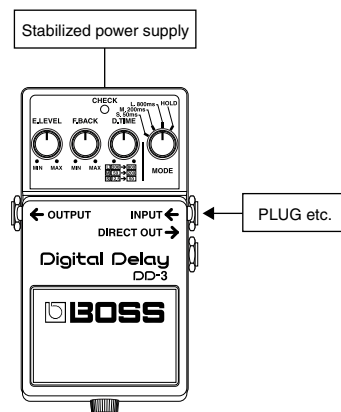

2. Adjust the **MODE** control to a setting other than **HOLD**.
3. Set the output voltage of the stabilized power supply to **9.0 V**.
4. Depress the pedal to make the **CHECK** LED light up.
5. Set the output voltage of the stabilized power supply to **7.0 V**.
6. Verify that the **CHECK** LED dims.
7. Disconnect the stabilized power supply.
8. Verify that the **CHECK** LED lights up brightly.
9. Depress the pedal several times, and verify that the **CHECK** LED repeatedly lights up and goes dark.
10. With the **CHECK** LED illuminated, disconnect the plug from the **INPUT** jack.
11. Verify that the **CHECK** LED goes dark.

Circuit Board (Main, VR, LED, Input, Output, SW Board)

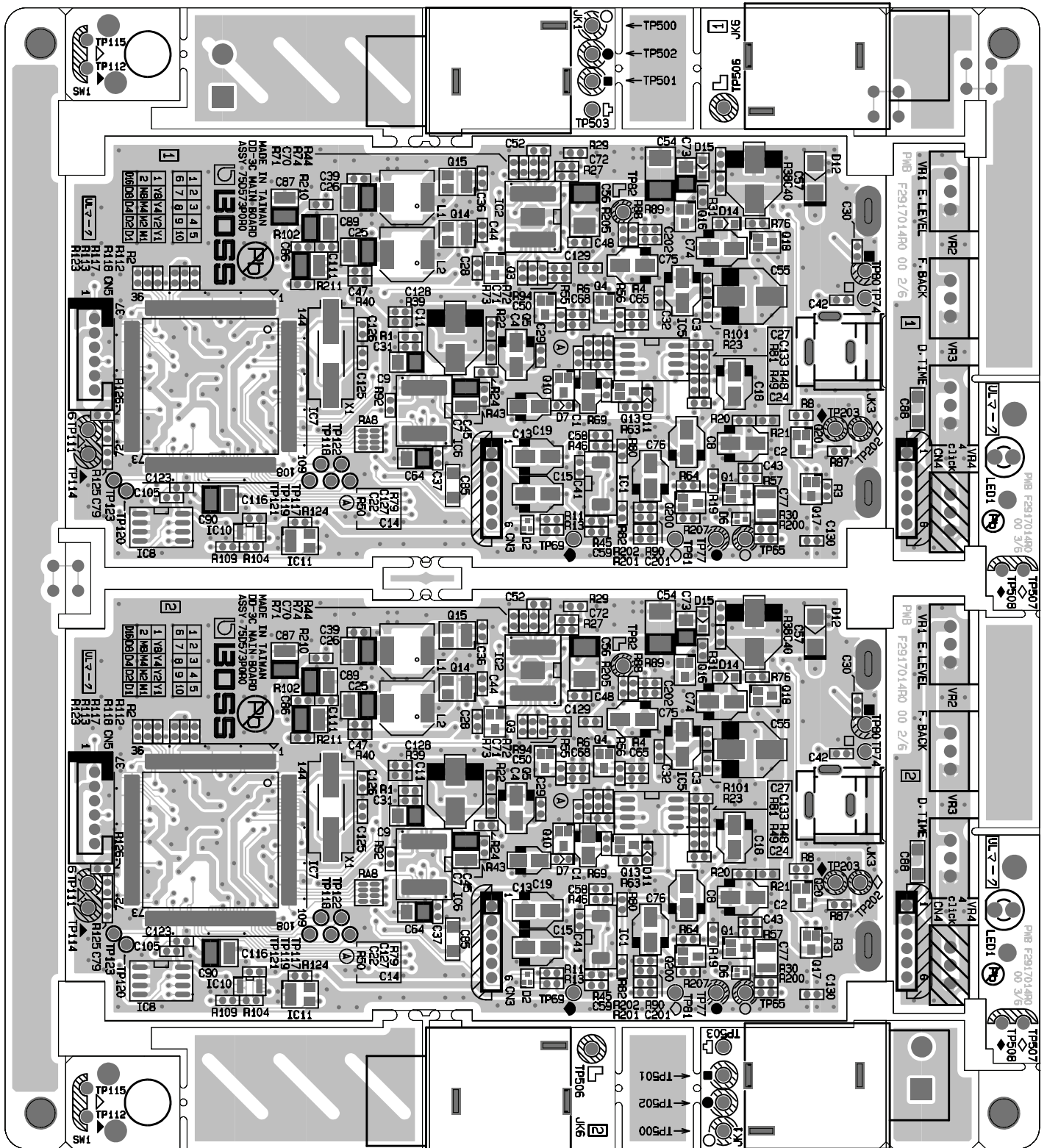

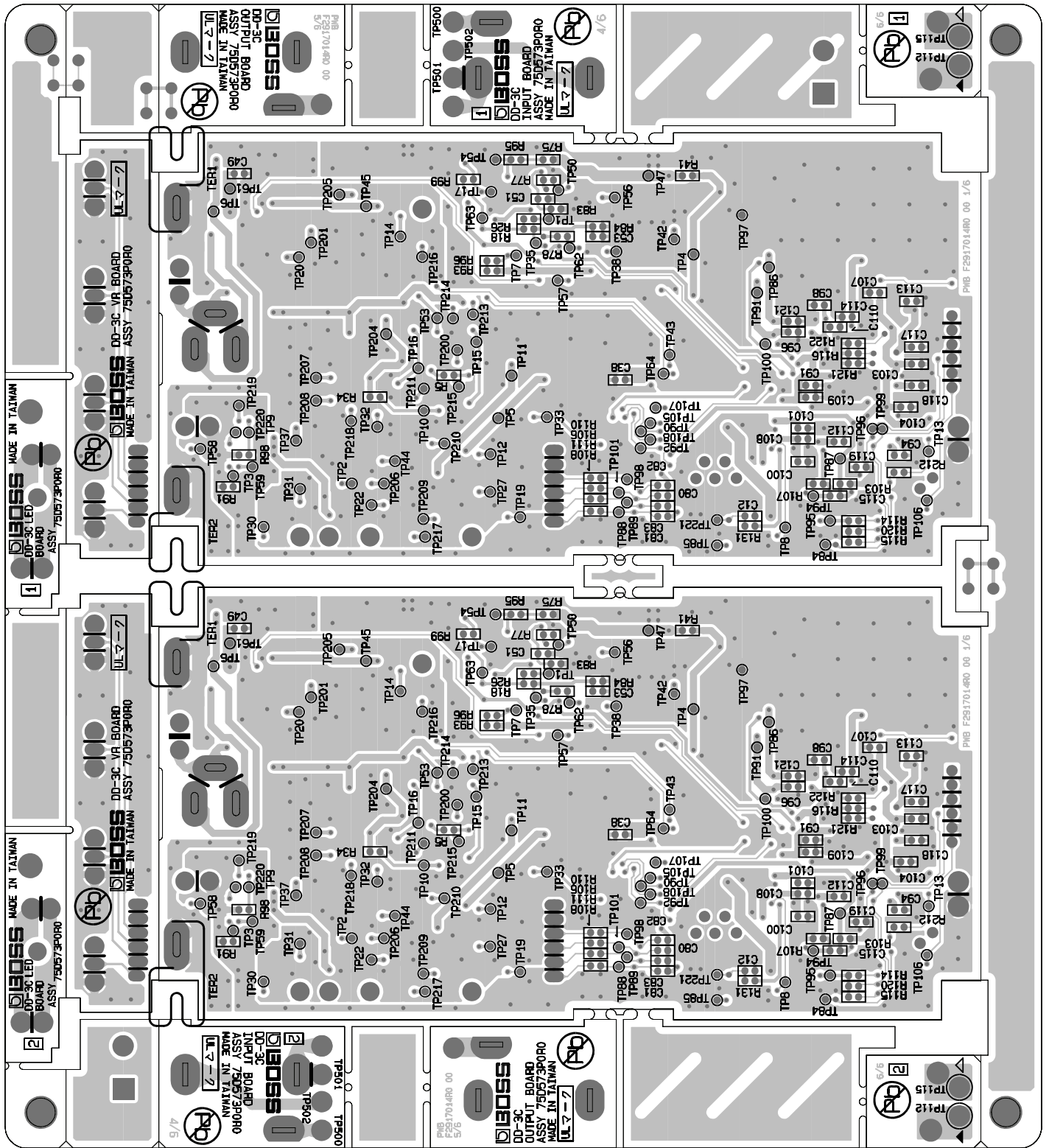

Circuit Diagram (Main, VR, LED, Input, Output, SW Board)

DD-3C Circuit Diagram MAIN BOARD

PWB F2917014R0 1/6
ASSY 75D573P0R0

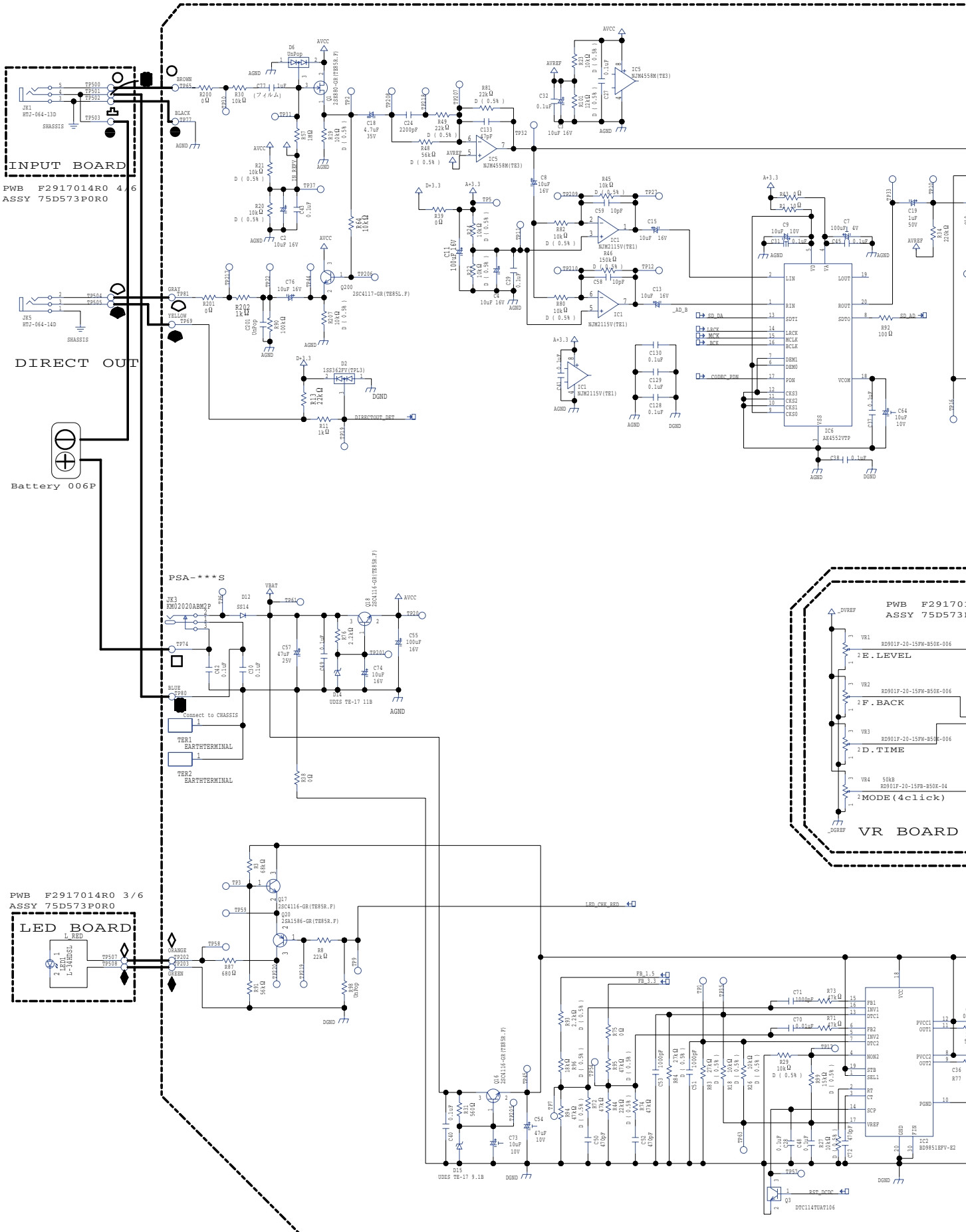

* The symbols appearing at the TP locations are silkscreened on the circuit board. Identical symbols are mutually connected by wiring.

