

T-29-05-20

MITSUBISHI <LINEAR ICs>

M5201L, P, FP

**GENERAL PURPOSE SWITCHING OPERATIONAL AMPLIFIER
(DUAL INPUT, SINGLE OUTPUT TYPE)**

MITSUBISHI ELEK (LINEAR) 53E D ■ 6249826 0014044 511 ■ MIT2

DESCRIPTION

The M5201 is a semiconductor integrated circuit designed for an operational amplifier which adopts analog switch function, having dual inputs of A and B and a single output. The device comes in an 8-pin SIP, DIP or FP and contains input differential circuits of A and B type, single output circuit and a switching circuit of an operational amplifier, and can be used as a conventional operational amplifier, turning on A or B inputs by externally setting the control pin at high or low level. For a voltage follower condition where $G_V = 0\text{dB}$, the device functions merely as an analog switch, but, for an amplifier with a switching function, gain can be set independently for A and B inputs. The M5201 operational amplifier has basic characteristics similar to those of the M5218/M5R4558P and can be widely used as audio, video and musical instrument equipments.

FEATURES

- Operational amplifier inputs of A and B type and gain can be set independently
- Applicable to both single and dual power supplies
- High gain, low distortion
..... $G_{VO} = 100\text{dB}$, $\text{THD} = 0.002\%$ (typ.)
- High slew rate, high f_T $\text{SR} = 2.2\text{V}/\mu\text{s}$, $f_T = 7\text{MHz}$ (typ.)
- Low noise ($R_S = 1\text{k}\Omega$) FLAT $V_{NI} = 2\mu\text{Vrms}$ (typ.)
- Small switching shock noise
- High load current, high power dissipation
..... $I_{LP} = \pm 50\text{mA}$, $P_d = 800\text{mW}$ (SIP)
..... $P_d = 625\text{mW}$ (DIP)
..... $P_d = 440\text{mW}$ (FP)

PIN CONFIGURATION (TOP VIEW)

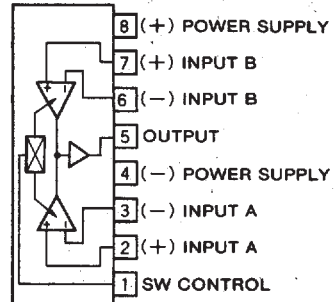

Outline 8P5 (M5201L)

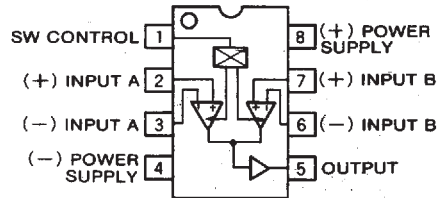

Outline 8P4 (M5201P) 8P2S (M5201FP)

RECOMMENDED OPERATING CONDITIONS

Supply voltage range $\pm 2.5 \sim \pm 16\text{V}$
 Rated supply voltage $\pm 15\text{V}$

EQUIVALENT CIRCUIT

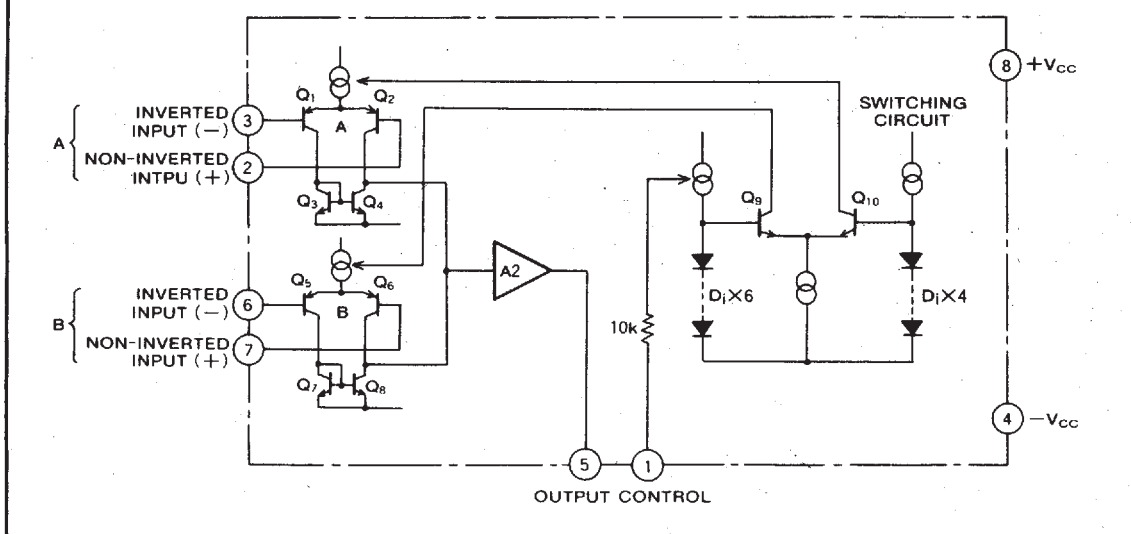

M5201L. P. FP

MITSUBISHI ELEK (LINEAR) 53E D ■ 6249826 0014045 458 ■ MIT2

**GENERAL PURPOSE SWITCHING OPERATIONAL AMPLIFIER
(DUAL INPUT, SINGLE OUTPUT TYPE)**

ABSOLUTE MAXIMUM RATINGS

Symbol	Parameter	Rated	Unit
V_{CC}	Supply voltage	$\pm 18(36)$	V
V_{id}	Differential input voltage	± 30	V
V_{ic}	Common phase input voltage	± 15	V
I_{LP}	Load current	± 50	mA
P_d	Power dissipation	800(SIP)/625(DIP)/440(FP)	mW
T_{opr}	Ambient temperature	$-20 \sim +75$	$^{\circ}C$
T_{stg}	Storage temperature	$-55 \sim +125$	$^{\circ}C$

ELECTRICAL CHARACTERISTICS ($V_{CC} = \pm 15V$)

Symbol	Parameter	Test conditions	Limits			Unit
			Min	Typ	Max	
I_{CC}	Circuit current	V_{in}	SW ON	2.3	6.0	mA
			SW OFF	2.1	6.0	
V_{IO}	Input offset voltage	$R_s = 10k\Omega$	0.8	6.0	mV	
I_B	Input bias current		80	500	nA	
G_{VO}	Open loop voltage gain	$R_L = 2k\Omega$		100	dB	
V_{OM}	Maximum output voltage	$R_L \geq 10k\Omega$	± 12	± 14	V	
THD	Total harmonic distortion	$f = 1kHz, V_O = 5V_{rms}, G_V = 20dB$		0.002	%	
SVR	Supply voltage rejection ratio			20	150	$\mu V/V$
C·S	Channel separation	$f = 1kHz$		82	dB	
f_T	Gain bandwidth product	$G_V = 0dB$		7	MHz	
SR	Slew rate	$G_V = 0dB, R_L = 2k\Omega // 100pF$		2.2	$V/\mu s$	
V_{NI}	Input referred noise voltage	$R_s = 1k\Omega, BW = 10Hz \sim 30kHz, Flat$		2.0	μV_{rms}	

TEST CIRCUIT

(1) I_{CC}, V_{IO}, SVR

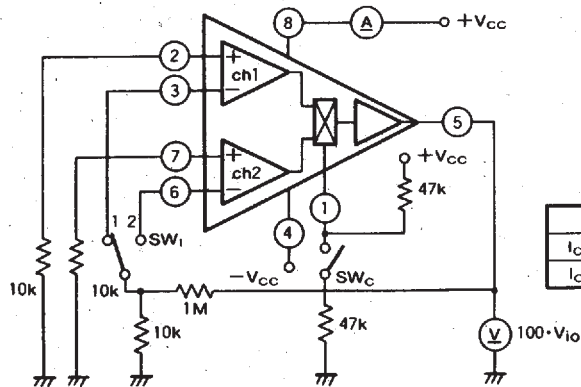

	SW_C	SW_1	Select ch
I_{CC1}, V_{IO1}, SVR_1	OFF	1	ch1
I_{CC2}, V_{IO2}, SVR_2	ON	2	ch2

Unit Resistance : Ω
capacitance : F

M5201L, P, FP

**GENERAL PURPOSE SWITCHING OPERATIONAL AMPLIFIER
(DUAL INPUT, SINGLE OUTPUT TYPE)**

MITSUBISHI ELEK (LINEAR) 53E D ■ 6249826 0014046 394 ■ MIT2

(2) I_b, I_{io}

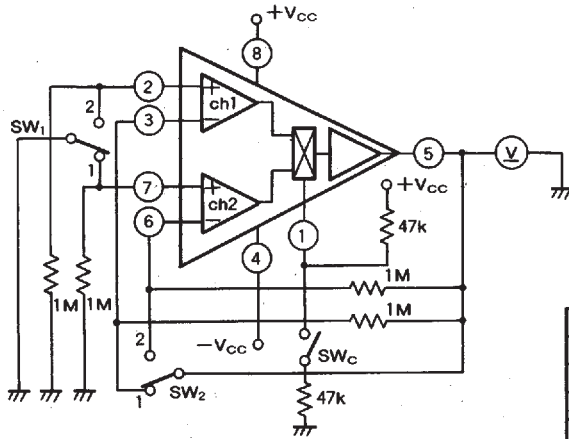

$$I_b^+ = V_o^+ / 1M\Omega$$

$$I_b^- = V_o^- / 1M\Omega$$

$$I_{io} = |I_b^+ - I_b^-|$$

	SW _C	SW ₁	SW ₂	Select ch
V _{O1}	OFF	1	1	ch1
V _{O1}	OFF	2	2	ch1
V _{O2}	ON	2	2	ch2
V _{O2}	ON	1	1	ch2

(3) f_t, G_v

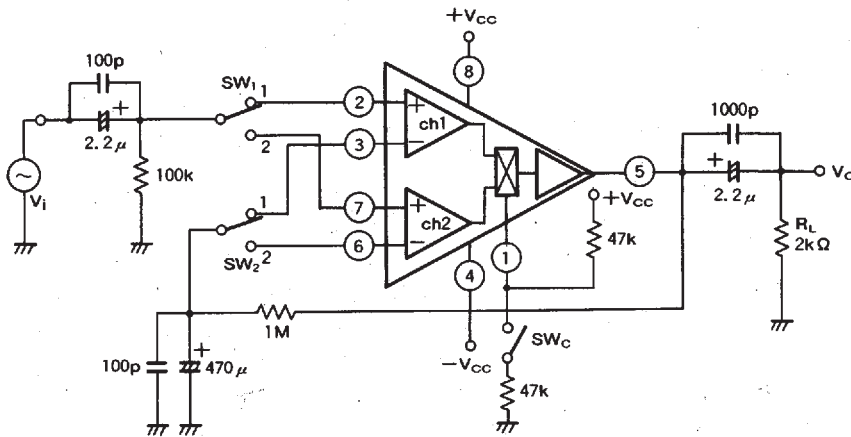

	SW _C	SW ₁	SW ₂	Select ch
f_{t1}, G_{v1}	OFF	1	1	ch1
f_{t2}, G_{v2}	ON	2	2	ch2

Unit Resistance: Ω
Capacitance: F

M5201L, P, FP

**GENERAL PURPOSE SWITCHING OPERATIONAL AMPLIFIER
(DUAL INPUT, SINGLE OUTPUT TYPE)**

MITSUBISHI ELEK (LINEAR) 53E D ■ 6249826 0014047 220 ■ MIT2

TYPICAL CHARACTERISTICS

THERMAL DERATING (MAXIMUM RATING)

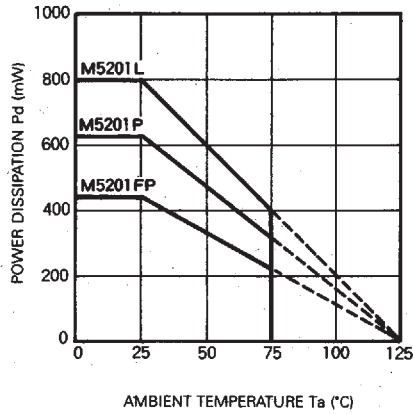

VOLTAGE GAIN VS. FREQUENCY RESPONSE

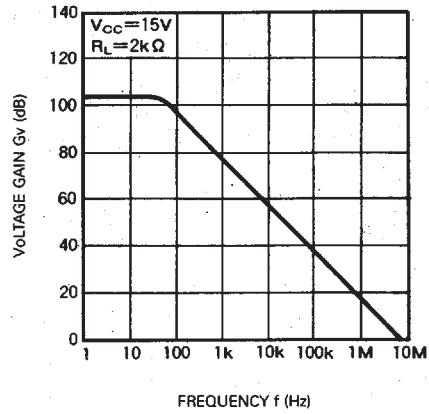

CIRCUIT CURRENT VS. SUPPLY VOLTAGE

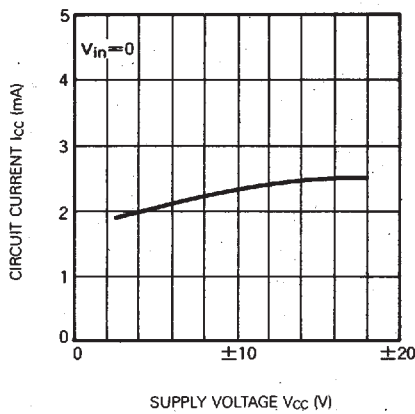

OUTPUT VOLTAGE/LOAD CURRENT PEAK VS. LOAD RESISTANCE

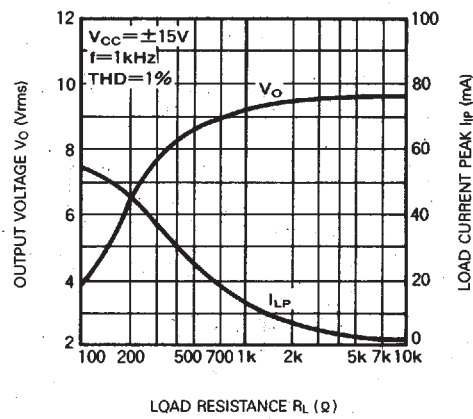

MAXIMUM OUTPUT VOLTAGE VS. SUPPLY VOLTAGE

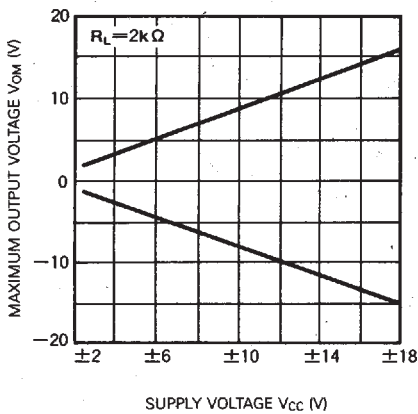

MAXIMUM OUTPUT VOLTAGE VS. FREQUENCY RESPONSE

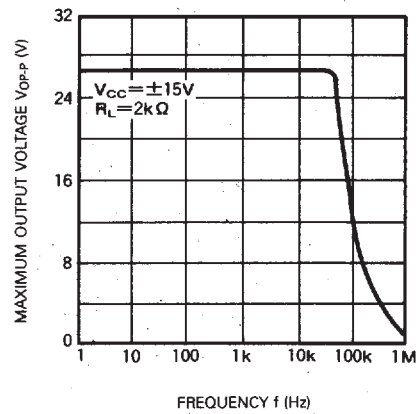

**GENERAL PURPOSE SWITCHING OPERATIONAL AMPLIFIER
 (DUAL INPUT, SINGLE OUTPUT TYPE)**

MITSUBISHI ELEK (LINEAR) 53E D ■ 6249826 0014048 167 ■ MIT2
APPLICATION CIRCUIT

(1) FLAT amplifier ($G_v \approx 10\text{dB}$) + analog switch circuit

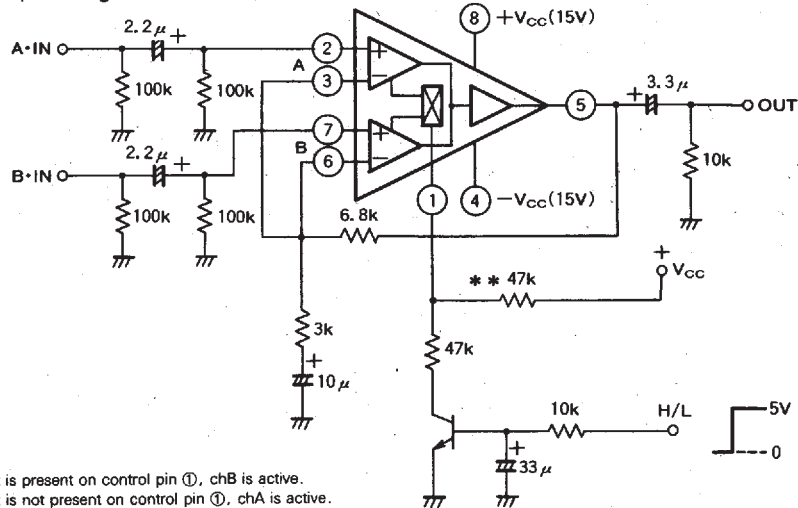

* When the current is present on control pin ①, chB is active.
 When the current is not present on control pin ①, chA is active.

(2) Analog switch circuit ($D_v = 0\text{dB}$, voltage follower amplifier)

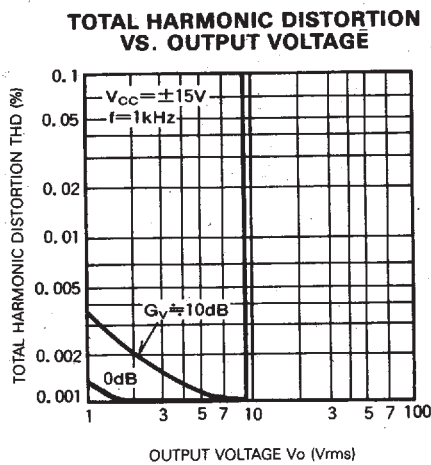
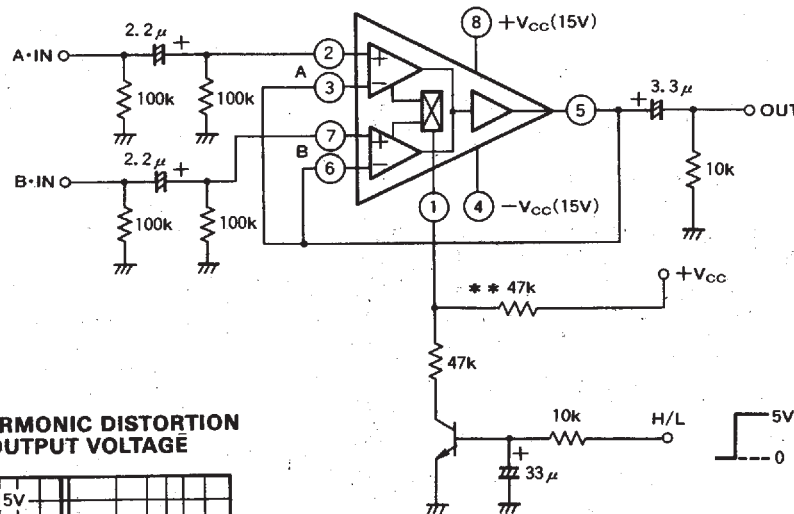

A resistor indicated by ** is a pull-up resistor to prevent switching pin ① from being activated by the leak current from an external circuit (i. e. TR).

MITSUBISHI <LINEAR ICs>
M5201L, P, FP

**GENERAL PURPOSE SWITCHING OPERATIONAL AMPLIFIER
(DUAL INPUT, SINGLE OUTPUT TYPE)**

MITSUBISHI ELEK (LINEAR)
TYPICAL APPLICATION CIRCUIT

53E D ■ 6249826 0014049 0T3 ■ MIT2

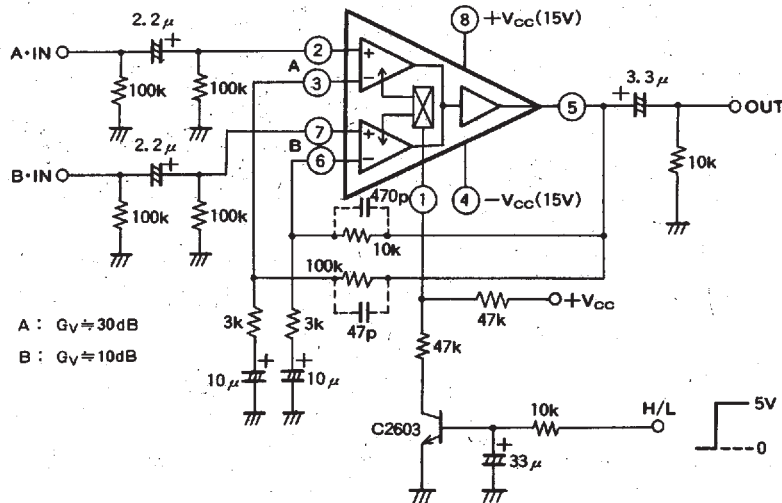

*When the current is present on control pin ①, chB is active. When the current is not present on control pin ①, chA is active.

Unit Resistance: Ω
 Capacitance: F

PCB FOR CIRCUIT TESTING

WIRING ON THE PCB

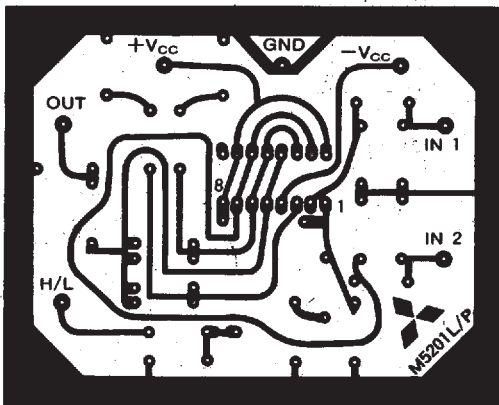

(PARTS INSERTION SIDE)

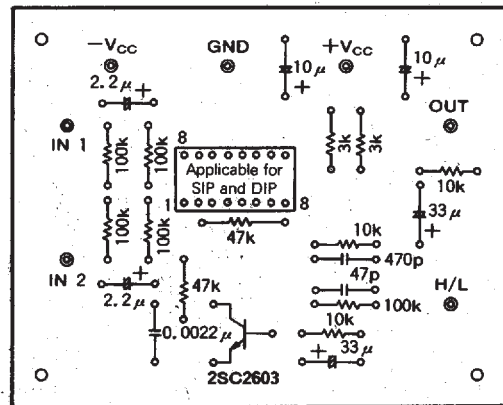

M5201L, P, FP

**GENERAL PURPOSE SWITCHING OPERATIONAL AMPLIFIER
(DUAL INPUT, SINGLE OUTPUT TYPE)**

MITSUBISHI ELEK (LINEAR) 53E D

6249826 0014050 815 MIT2

SHOCK NOISE MEASUREMENT

TEST CIRCUIT

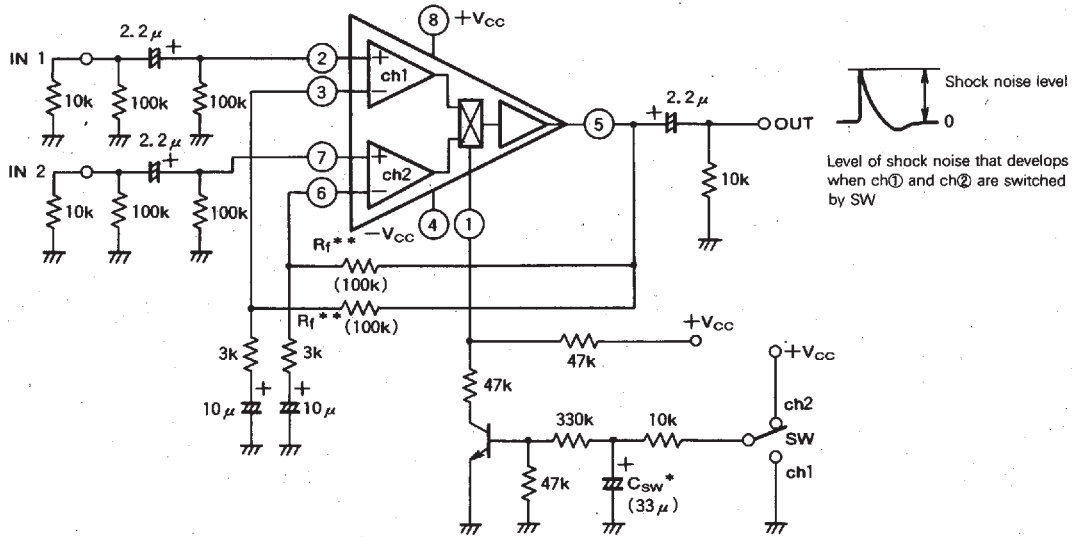

SHOCK NOISE VS. CAPACITOR C_{sw}

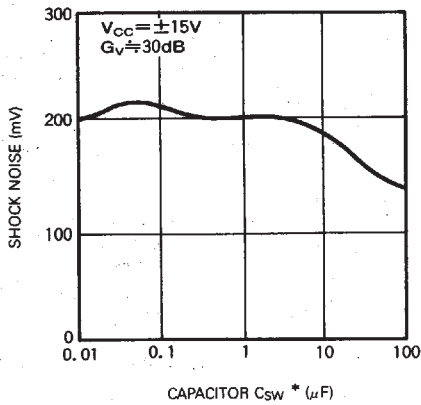

* Characteristic of shock noise with respect to change of C_{sw}

SHOCK NOISE VS. VOLTAGE GAIN

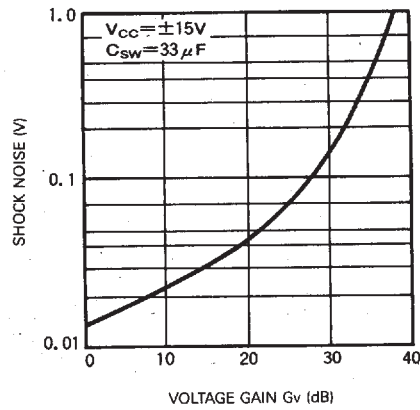

** Characteristic of shock noise with respect to voltage gain varied by R_1 .

M5201L, P, FP

**GENERAL PURPOSE SWITCHING OPERATIONAL AMPLIFIER
(DUAL INPUT, SINGLE OUTPUT TYPE)**

MITSUBISHI ELEK (LINEAR) 53E D ■ 6249826 0014051 751 ■ MIT2

CHANNEL SEPARATION (C-S)

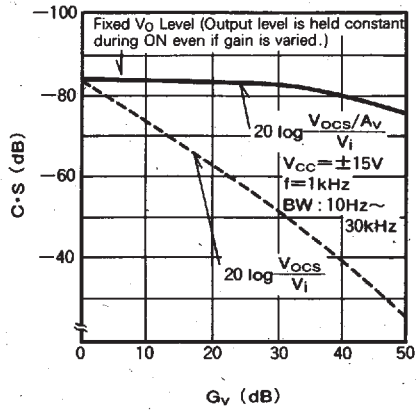

(A:OFF/B:IN ON MODE)

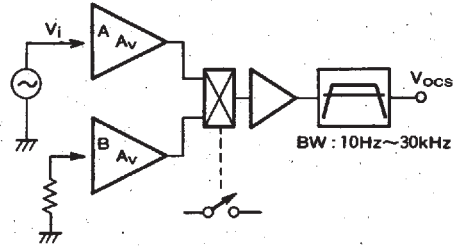

$$C \cdot S = 20 \log \left[\frac{\text{INPUT LEAK LEVEL}}{\text{SIGNAL LEVEL}} \right] \text{ (dB)}$$

$$= 20 \log \frac{V_{Ocs}/A_v}{V_i} \text{ (dB)}$$

Channel separation is defined as the ratio of the leak signal (that is scaled on the assumption it is present in the input) to the input signal.

$$\left(20 \log \frac{V_{Ocs}/A_v}{V_i} \right)$$

However, as indicated by the above broken line, if gain (A_v) is not scaled, channel separation appears to be deteriorated by as much as the amplified amount.

$$\left(20 \log \frac{V_{Ocs}}{V_i} \right)$$

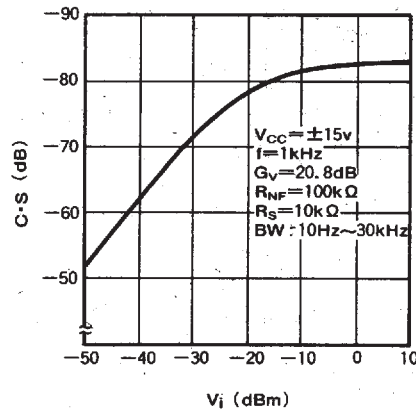
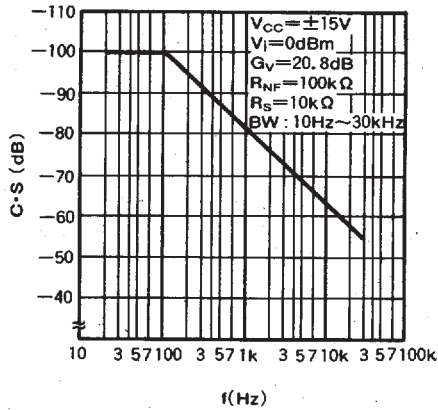

M5201L, P, FP

**GENERAL PURPOSE SWITCHING OPERATIONAL AMPLIFIER
(DUAL INPUT, SINGLE OUTPUT TYPE)**

MITSUBISHI ELEK (LINEAR) 53E D ■ 6249826 0014052 698 ■ MIT2

SWITCHING MECHANISM

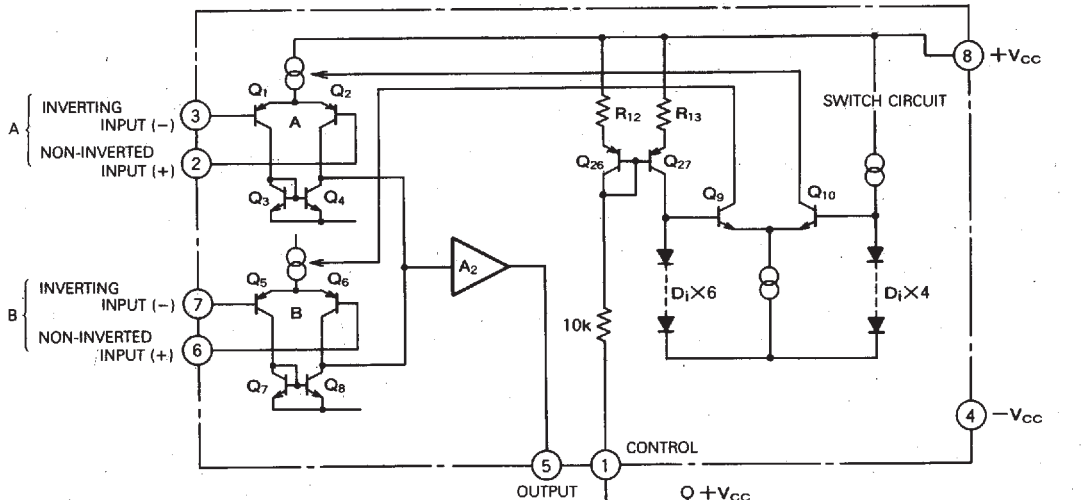

As shown in the above figure, the M5201 transfers switching signals by externally feeding the current to the V_F on the Q_{26} side of the current mirror transistor circuit (which consists of transistors Q_{26} and Q_{27}). That is, when no current is fed to pin ①, Q_{10} is turned on by four diodes connected to Q_{10} to activate the amplifier for channel A. When current is fed to pin ①, the collector current to Q_9 flows to turn on the six diodes connected to Q_9 and channel B is activated. Thus, applying and removing current to/from pin ① switches an active channel, therefore, M5203 can arbitrarily control the driving method regardless of the type of power supply (single or dual).

It is recommended to connect a pull-up resistor R_p to pin ① to reduce current sensitivity of transistor Q_{26} because a very small current may turn on the V_F .

