

REVISION RECORD			
LTR	EGD NO.	APPROVED:	DATE

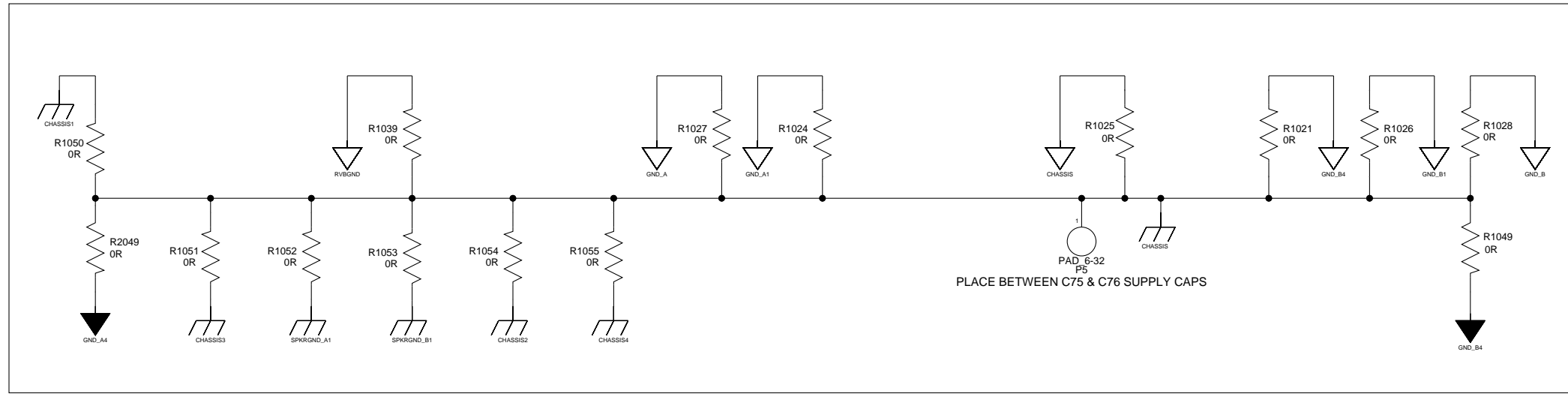
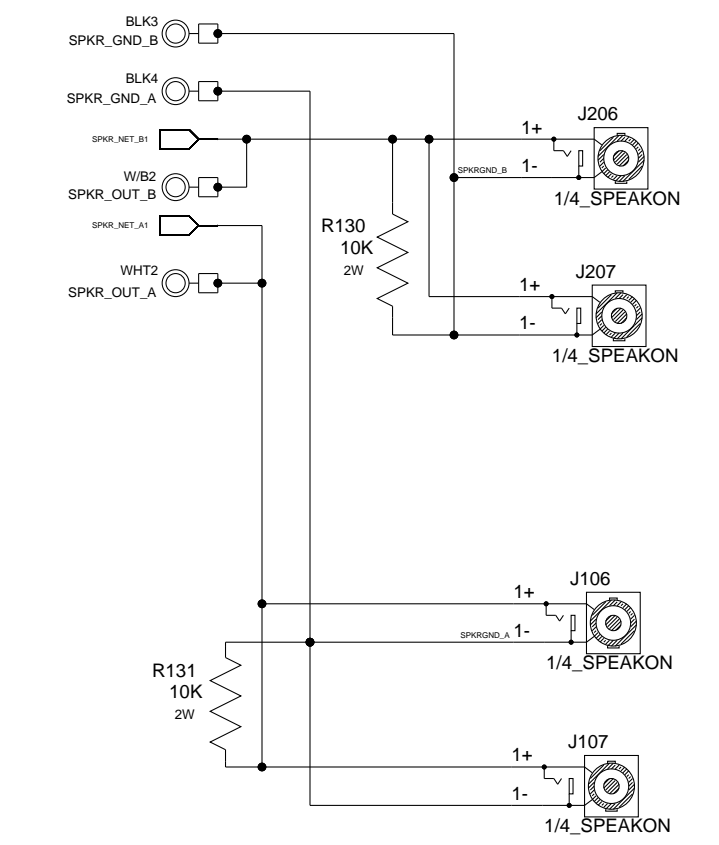
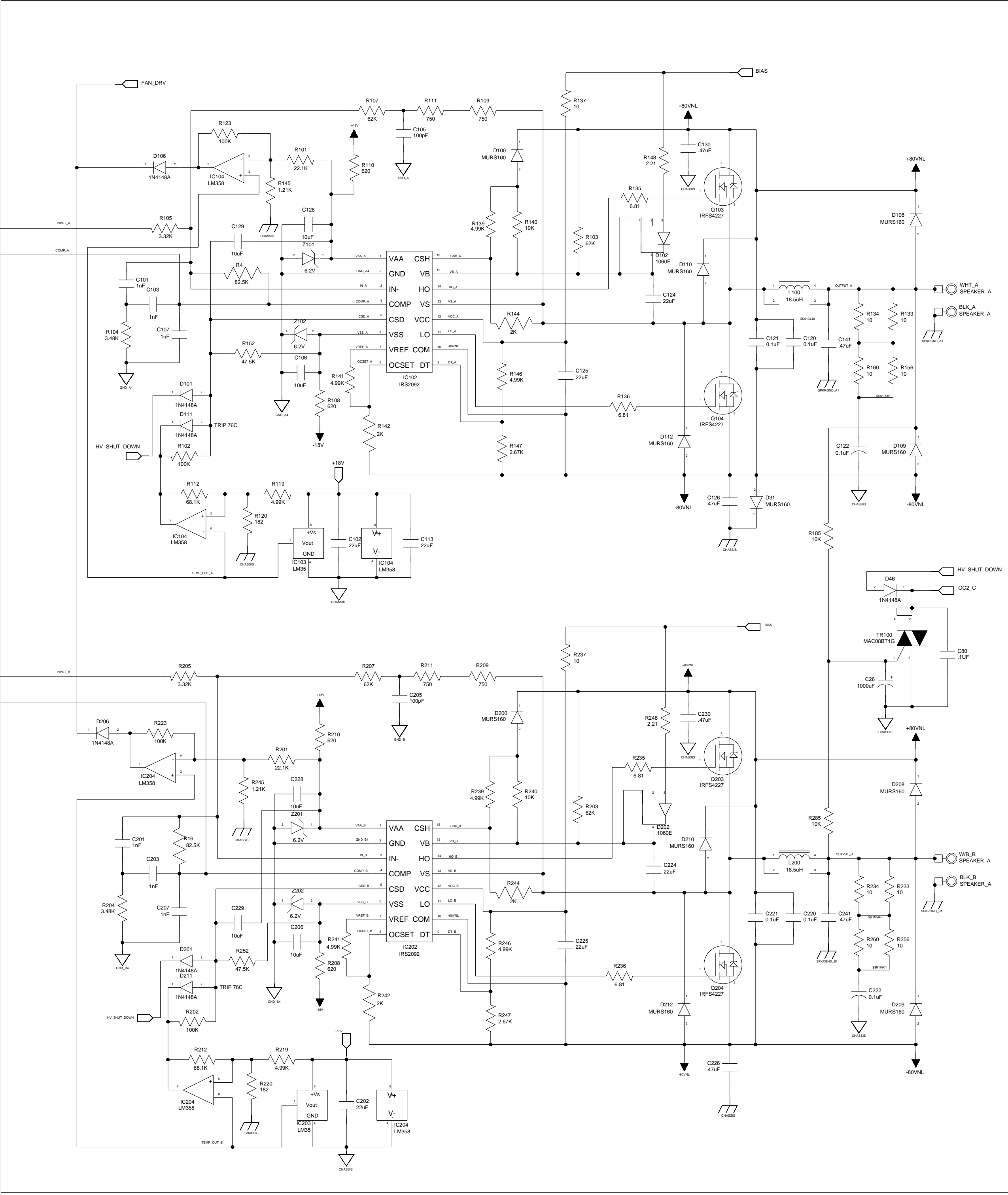
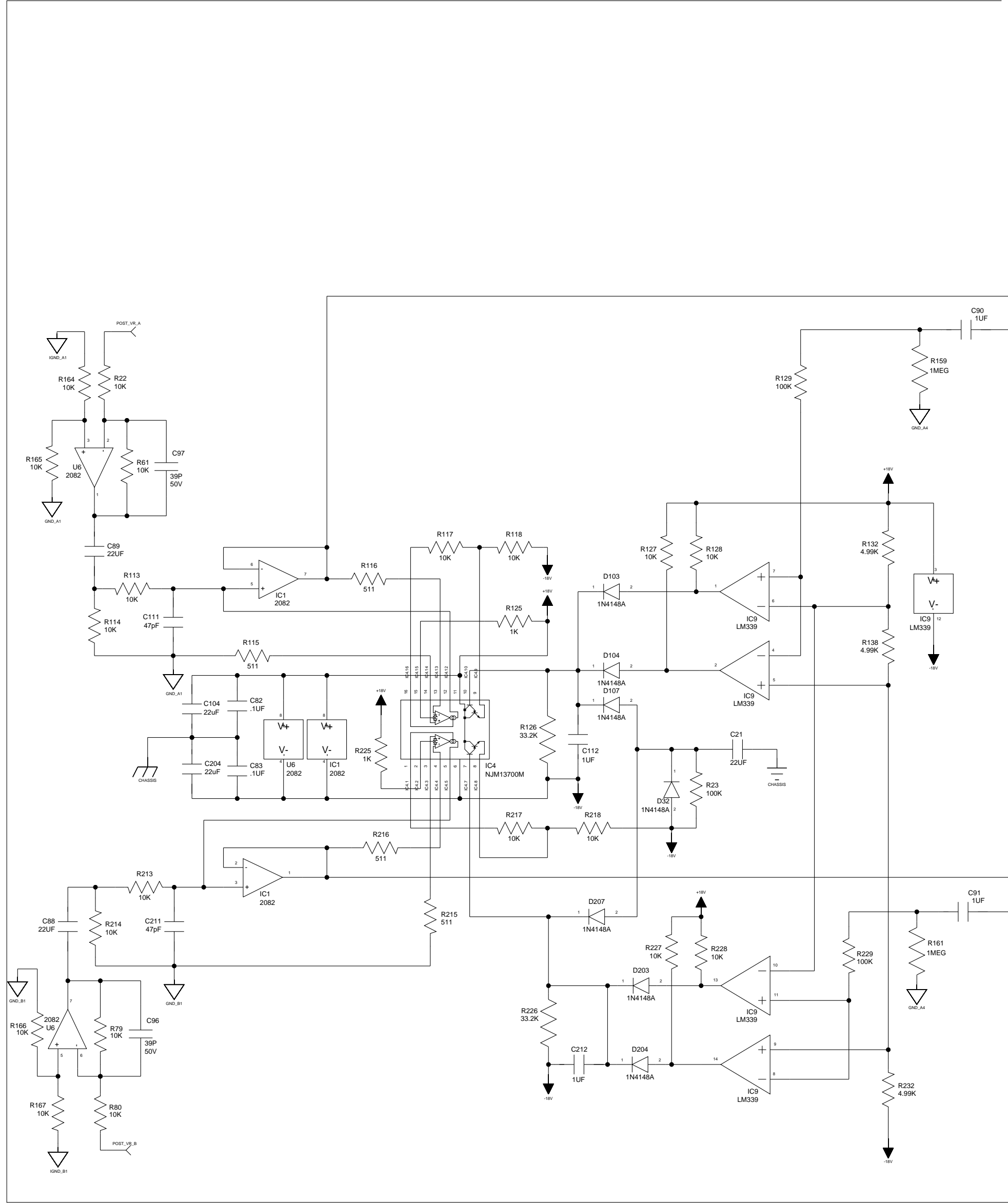

F01	F03	F05	TAB0
F02	F04	F06	TAB1
F03	F04	F06	TAB

PEAVEY ELECTRONICS INC.			
TITLE: XR1212 Amplifier			
DRAWN: jdb	DATED: 10/08/07	CODE:	REV: 02
CHECKED:	DATED:	SIZE:	DRAWING NO:
QUALITY CONTROL:	DATED:	SCALE:	SHEET: 1 OF 1

REVISION RECORD			
LTR	ECO NO.	APPROVED	DATE

6

5

4

3

2

1

D

D

C

C

B

B

A

A

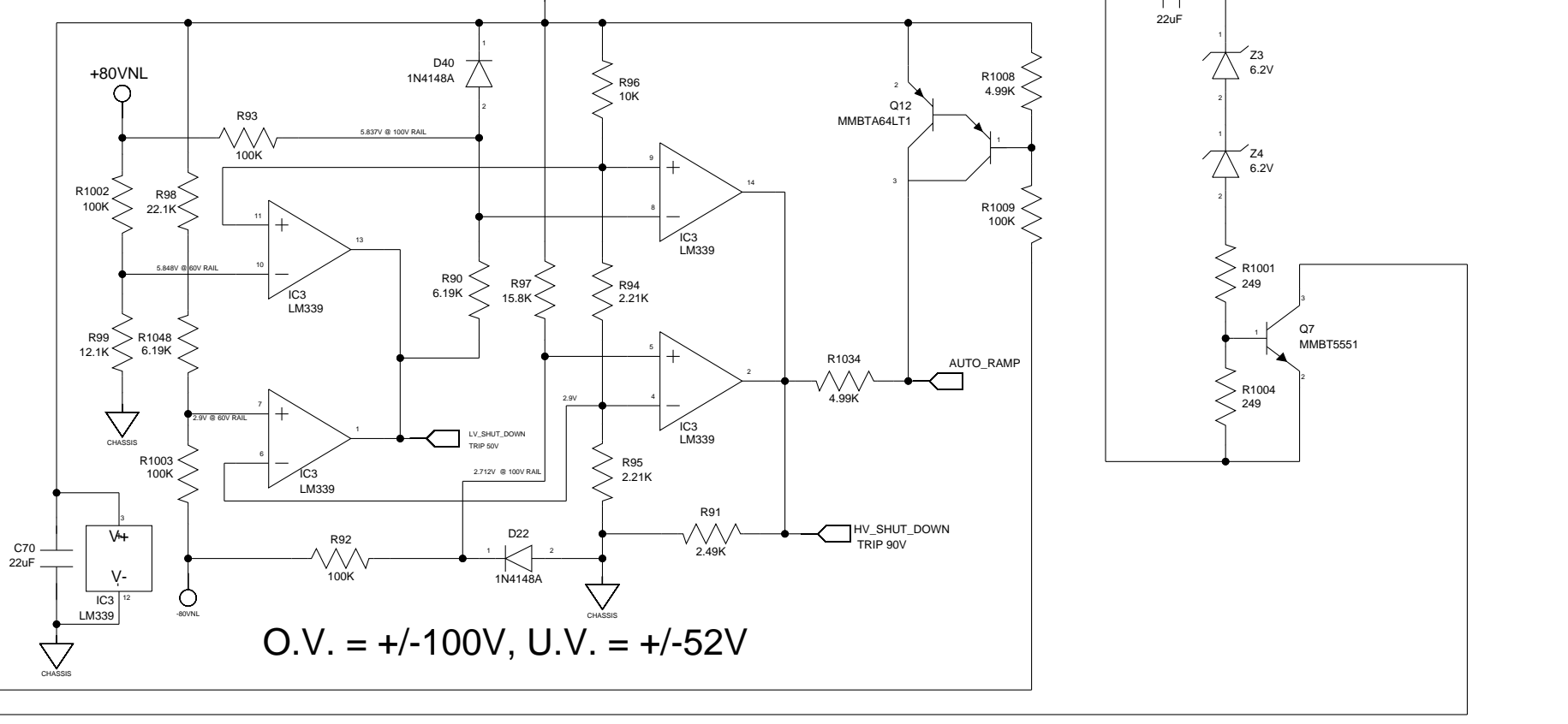
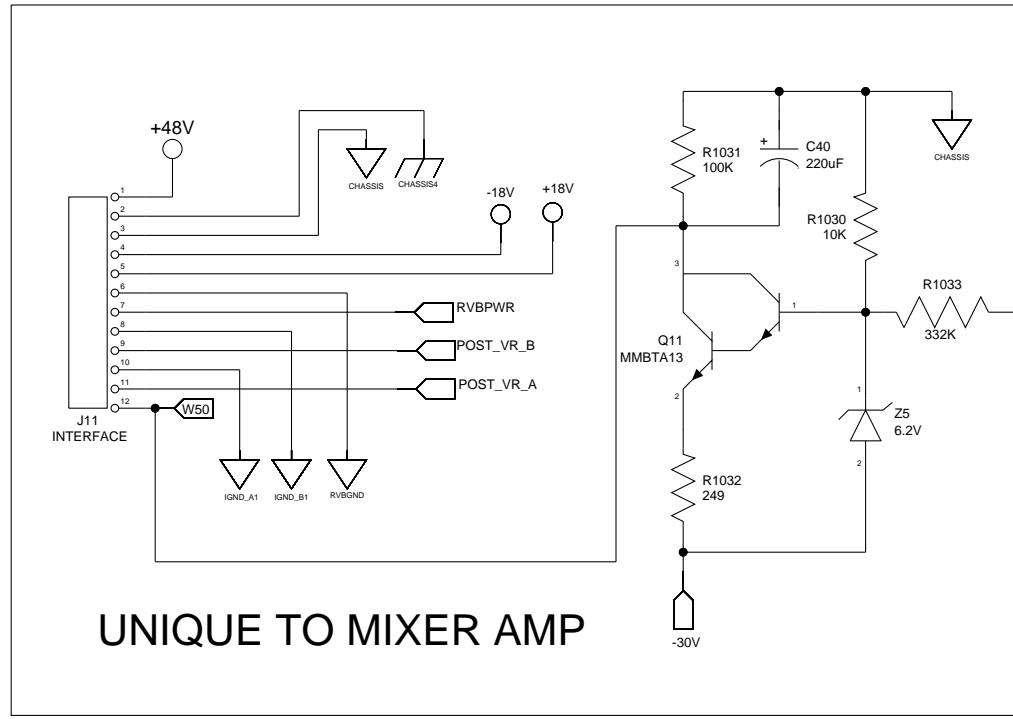
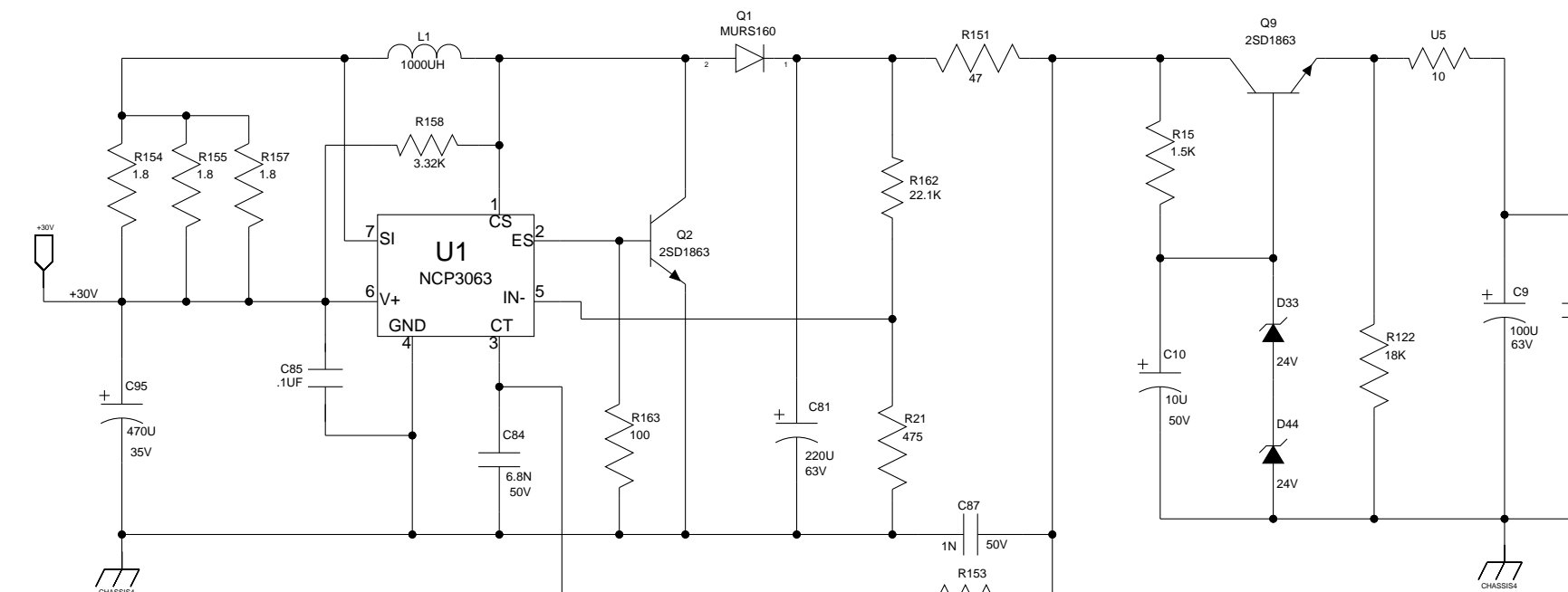
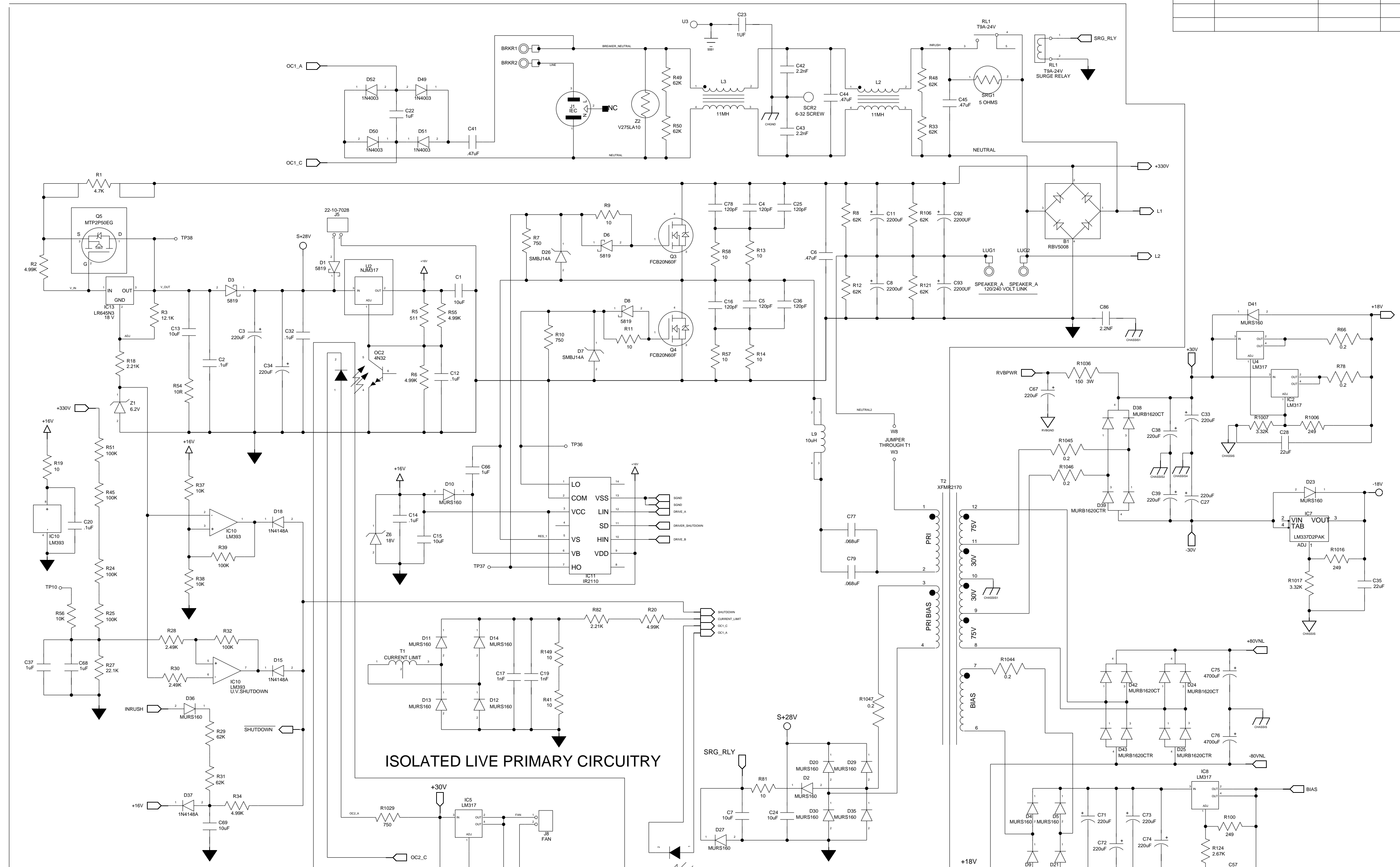
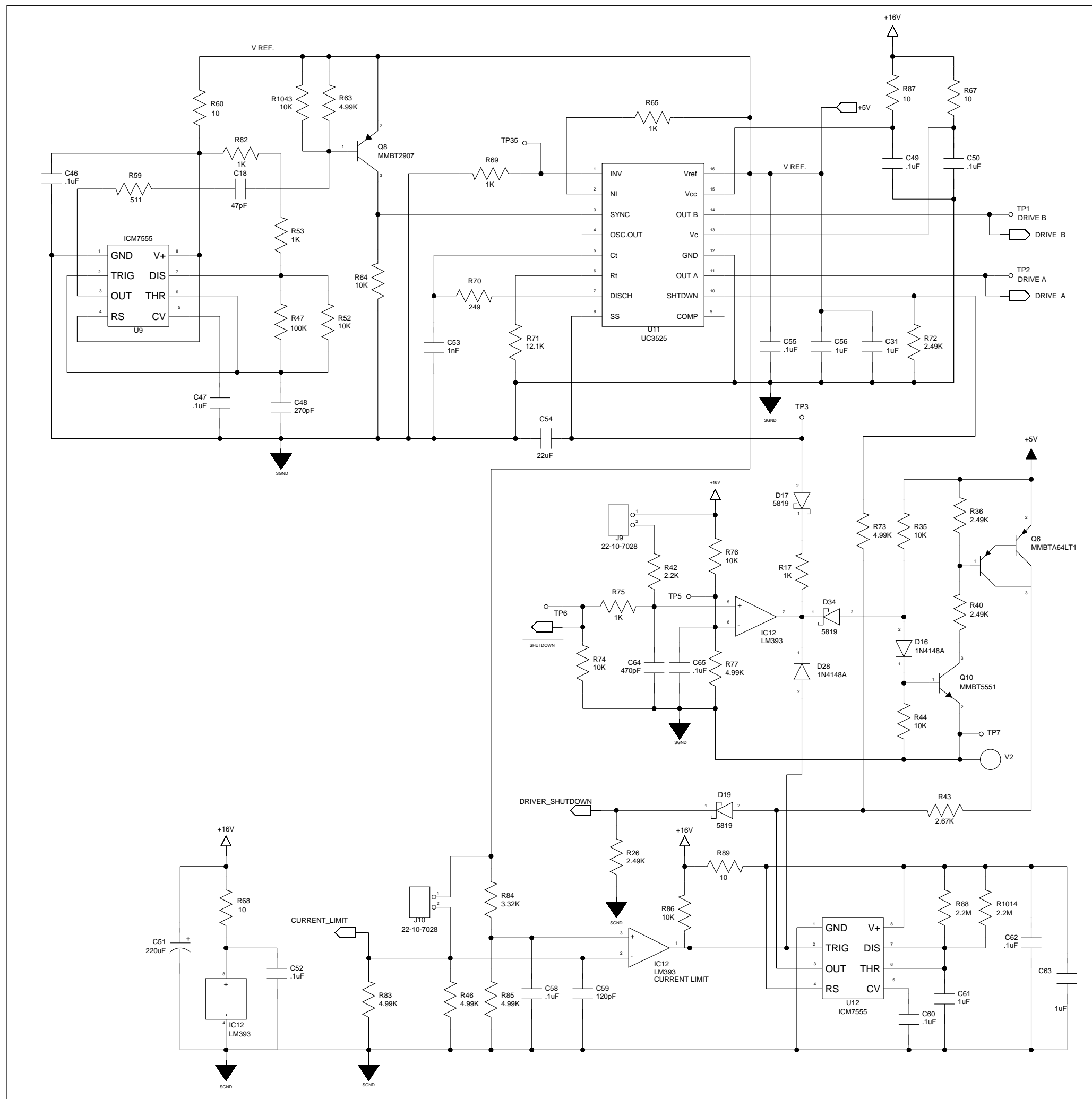

O.V. = +/-100V, U.V. = +/-52V

PCB Material FR-4/24 for a rating of 150C

PEAVEY ELECTRONICS INC.				
TITLE: Power Supply				
DRAWN: F.D.B.	DATED:	CODE:	SIZE: D	DRAWING NO.:
CHECKED:	DATED:	SCALE:	SHEET: 2 OF 2	REV:
QUALITY CONTROL:	DATED:			
RELEASED:	DATED:			

DELETE Q102, R121, R122 FOR MIXER VERSION
DELETE Q100, R131, R130 FOR MIXER VERSION
DELETE Q202, R221, R222 FOR MIXER VERSION
DELETE Q200, R231, R230 FOR MIXER VERSION
9/10/07 CHANGE Rx42 & Rx44 TO 1K FOR 4 OHM LIMIT FOR MIXER VERSION

8/8/07 ADDED 47.5K ACROSS Cx29
9/19/07 DELETED SNUBBER PARTS R61, R66, R78, R79, R80, C77, C79, C21
9/4/07 CHANGED Rx14 CONNECTION
6/4/07 CORRECTED R73 TRACK ERROR
6/4/07 CORRECTED BRIDGE ROUTING
7/25/07 DELETED Cx14
9/4/07 CHANGED J4 & J7
8/7/07 CHANGED L9 TO 18.5uH 30500891
8/7/07 CHANGED ICx04 TO LM358
9/13/07 CHANGED R99 FROM 13.3KTO 12.1K 30200376
9/13/07 CHANGED R3, R71 R99 FROM 1206 TO 0805 30200376
9/12/07 PENDING CHANGE LCI INDUCTORS TO 8mH
9/12/07 CHANGED Rx33 & Rx34 TO FROM 22 TO 10 OHMS 30200239
6/12/07 CHANGED C22 FROM .47uF 30300253 TO .068uF
9/12/07 CHANGE R243 TO 4.99K 30200173
9/12/07 ADDED Rx56 & Rx60 10 OHMS 30200239 IN SERIES WITH Rx33 & Rx34
8/7/07 CHANGED Rx20 FROM 221 TO 200 30200373
8/5/07 CHANGED Rx42 & Rx44 FROM 4.99K TO 2K 30200204
9/4/07 ADDED TEMP AND DC LEDS + CIRCUITRY. DELETED PILOT
6/12/07 CHANGED C48 FROM 470pf 30300090 TO 270pF.
8/15/07 CHANGED Cx05 FROM 150pF 30300065 TO 100pF 500V 1210 2%
8/24/07 CHANGED VALUE OF R80, R79, R78, R66, R61 FROM 10R TO 22R
9/4/07 CHANGED Rx50 & Rx58 FROM 24.3K 0.1% TO 16K 1%
9/13/07 CHANGED R1048 ROM 1.21KTO 6.19K
6/4/07 CHANGED Rx47 FROM 1.5K 30200284 TO 2.67K 30200470
8/17/07 CHANGED Cx01, Cx03, Cx07 TO 1%
8/14/07 DELETED RX86 (DC PROTECT GATE RESISTORS)
8/8/07 CHANGE GATE RESISTORS TO 6.8R
9/10/07 FOR 24V FAN, ADD Z7. BYPASS FOR 12V FAN.
8/21/07 C26 CHANGED FROM 220uF TO 1000uF 30300082
9/13/07 CHANGED R98 FROM 16KTO 22.1K 30200256
9/14/07 BYPASS R82 AND CHANGE R20 TO 4.99K 30200173
8/6/07 CHANGED R90 FROM 6.81K 30200328 TO 6.19K
8/6/07 CHANGED R97 FROM 17.4K 30200428 TO 15.8K
8/7/07 ADDED NEGATIVE TO GROUND ANTI SPIKE DIODE
8/1/07 CHANGED RED PROTECT LEDS TO GREEN
8/6/07 CHANGED Rx04 FROM 221 30200183 TO 1.5K 30200284
7/31/07 ADDED Cx10 1nF 30300174
9/14/07 CHANGED R42 FROM 2.49K TO 2.21K 30200236
9/14/07 MOVED BREAKER TO LINE SIDE
9/14/07 FOR MIXER, CHANGE R82 TO 200 OHMS 30200373
9/14/07 ADDED Q1, Q2, R1012, R1013, D38, AND D42
9/14/07 CHANGED CONNECTION TO Cx29
9/17/07 RENAMED C22 TO C82 AND ADDED C83
9/17/07 DELETED R4
9/17/07 CHANGED R43 TO 2.67K 30200413
9/17/07 ADDED C22, D49, D50, D51, D52
9/17/07 CHANGED OC1 & OC2
9/21/07 CHANGED Rx04 to 3.48K
9/21/07 Deleted VRx00
9/24/07 Changed R1009 from 10K to 100K
9/24/07 Changed R1008 from 2.21K to 10K
9/24/07 Deleted Q9, R143, R243, C81
9/24/07 Changed R23 to 100K
9/24/07 Added C21 & D32
9/26/07 Changed Rx21 and Clip LED connection
9/26/07 Changed Rx31 and Active LED connection
9/28/07 Replaced R1 with R1056 - R1069